

Acme Screw Jacks

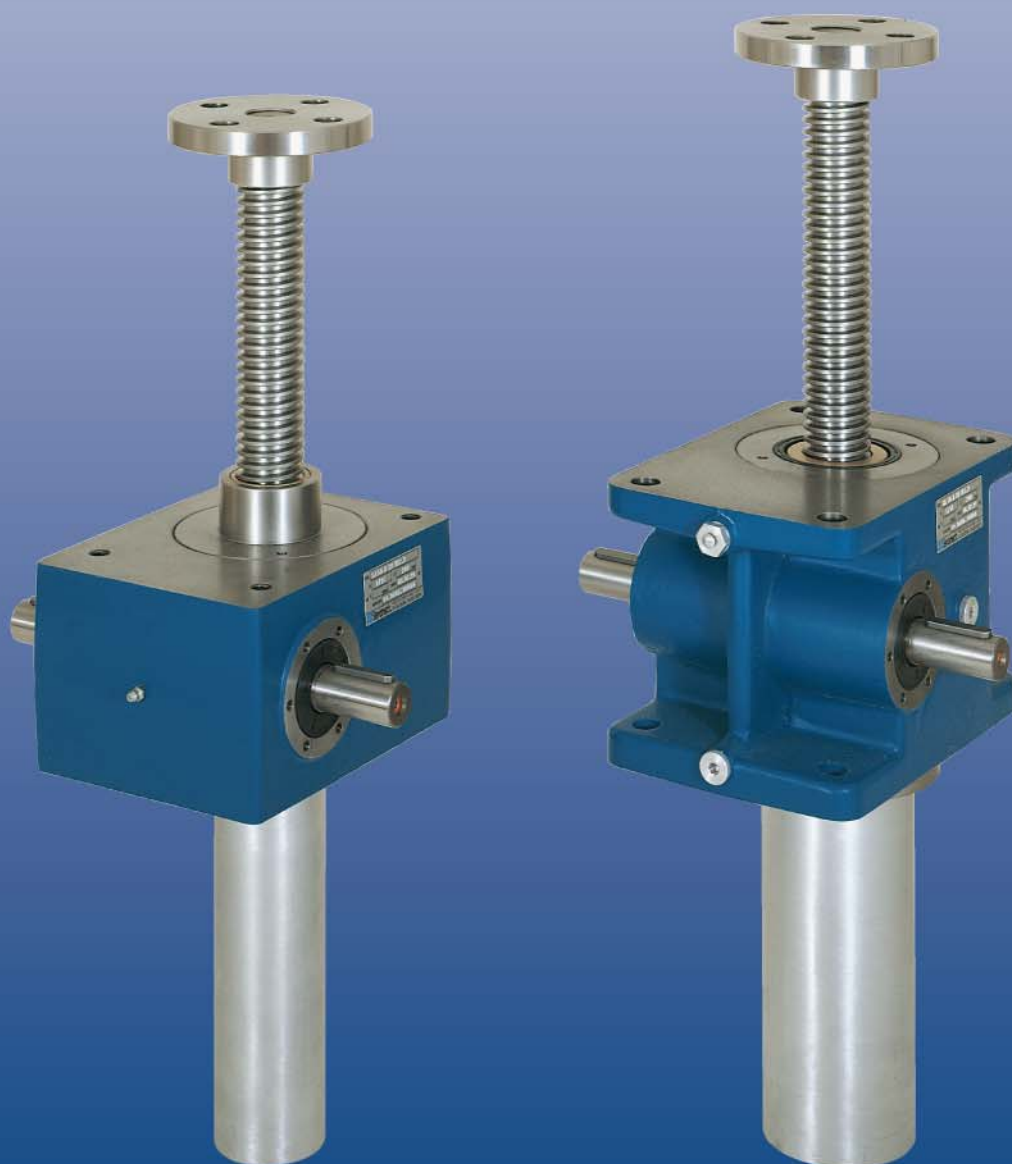

SERVOMECH Screw Jacks

MA Series Screw Jacks - high efficiency

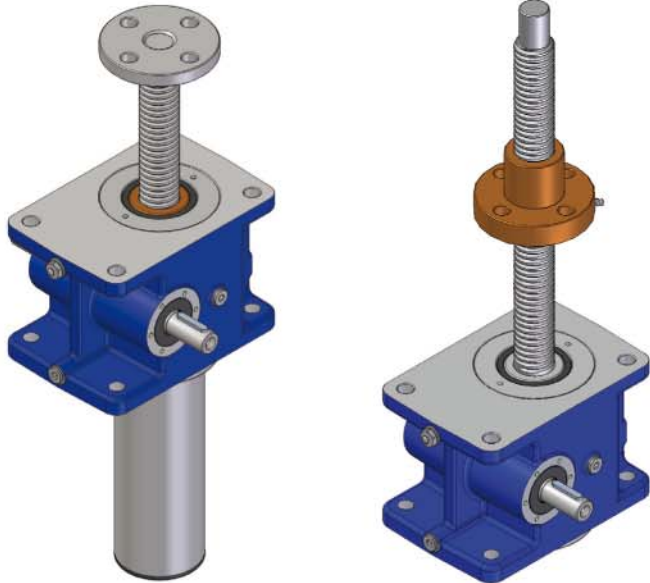

- Max. duty cycle:
 - travelling screw: 40 % over 10 min
(30 % over 1 hour)
 - travelling nut: 30 % over 10 min
(20 % over 1 hour)
- synthetic oil lubricated worm gearbox
- input speed up to 3 000 rpm
- 1-, 2-, 3- or 4-starts acme screw
- linear speed up to 300 mm/s
- 8 sizes
- load capacity ranging from 5 kN to 350 kN
- acme screw diameter from 18 mm to 100 mm

SJ Series Screw Jacks - standard performances

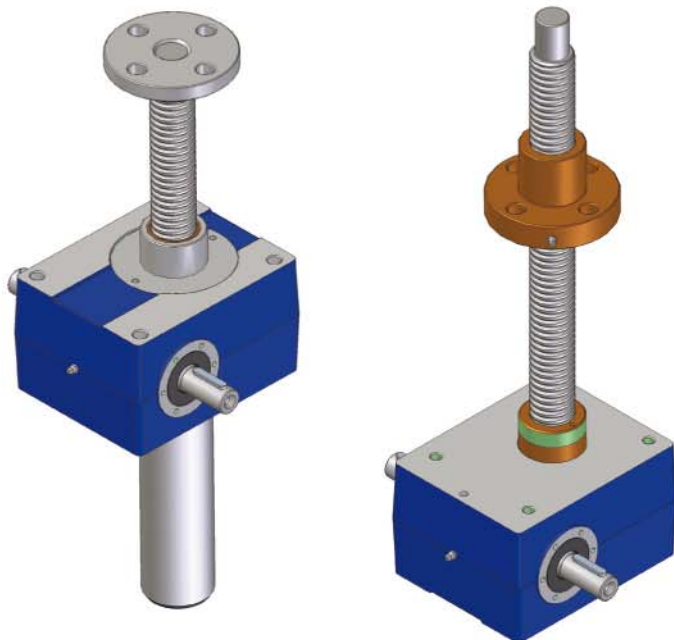

- Max. duty cycle:
 - 30 % over 10 min (20 % over 1 hour)
- synthetic grease lubricated worm gearbox
- input speed up to 1 500 rpm
- 1- or 2-starts acme screw
- linear speed up to 80 mm/s
- 14 sizes
- load capacity ranging from 5 kN to 1 000 kN
- acme screw diameter from 18 mm to 160 mm

© Copyright SERVOMECH 2011

This catalogue contents are under publisher copyright and may not be reproduced unless permission is agreed. Every care has been taken to ensure the accuracy of the information contained in this catalogue, but no liability can be accepted for any errors or omissions.

INDEX

1. General

Screw jacks overview	page 2
Manufacturing features	page 2
Materials and components	page 3
Acme screw jacks summary	page 4
Ball screw jacks summary	page 5
Models	page 6
Versions	page 7
Screw jacks selection criteria	page 8
Self-locking conditions	page 12
Acme screw buckling	page 13
Critical rotating speed of acme screw	page 16

2. MA Series screw jacks

Structural elements	page 18
MA Series screw jacks with 1-start acme screw - technical specifications	page 20
MA Series screw jacks with 1-start acme screw - performances	page 22
MA Series screw jacks with 2-starts acme screw - technical specifications	page 24
MA Series screw jacks with 2-starts acme screw - performances	page 26
MA Series screw jacks with 3-starts acme screw - technical specifications	page 28
MA Series screw jacks with 3-starts acme screw - performances	page 29
MA Series screw jacks with 4-starts acme screw - technical specifications	page 31
MA Series screw jacks with 4-starts acme screw - performances	page 32
Overall dimensions	page 34
Efficiency	page 36
Options	page 37
MA Series screw jacks - travelling screw (Mod.A) - coding description	page 48
MA Series screw jacks - travelling nut (Mod.B) - coding description	page 50
MA Series screw jacks - travelling screw (Mod.A) - spare parts	page 52
MA Series screw jacks - travelling nut (Mod.B) - spare parts	page 53

3. SJ Series screw jacks

Structural elements	page 54
SJ Series screw jacks with 1-start acme screw - technical specifications	page 56
SJ Series screw jacks with 1-start acme screw - performances	page 58
SJ Series screw jacks with 1-start acme screw - efficiency	page 61
SJ Series screw jacks with 2-starts acme screw - technical specifications	page 62
SJ Series screw jacks with 2-starts acme screw - performances	page 64
SJ Series screw jacks with 2-starts acme screw - efficiency	page 67
Overall dimensions	page 68
Options	page 72
SJ Series screw jacks - travelling screw (Mod.A) - coding description	page 80
SJ Series screw jacks - travelling nut (Mod.B) - coding description	page 82
SJ Series screw jacks - travelling screw (Mod.A) - spare parts	page 84
SJ Series screw jacks - travelling nut (Mod.B) - spare parts	page 85

4.

Installation – Maintenance - Lubricants	page 86
Product label	page 87
Screw jacks - travelling screw (Mod.A) - selection form	page 88
Screw jacks - travelling nut (Mod.B) - selection form	page 90
Screw jack dimensions check sheet	page 92
Screw jack lifting systems, lay-out	page 94

Screw jacks overview

Screw jacks transform a rotary motion from an electric, hydraulic or pneumatic motor or even manual operation into a linear movement in a vertical (push-pull lifting) or horizontal position.

Screw jacks can be installed as a single unit or in lifting systems with different layouts connected by drive-shafts, couplings and bevel gearboxes. Screw jacks enable the synchronized constant movement of lifting systems even with a varying load.

SERVOMECH screw jacks are able to work under either push or pull load conditions and mounted vertically upward, downward or horizontally.

SERVOMECH screw jacks models are available in two models:

- travelling screw (Model A)
- travelling nut (Model B)

SERVOMECH produces two screw jacks series: **MA** and **SJ**. Both series are available in different sizes in order to obtain the most suitable size in terms of performances and costs for each application.

MA Series: high performances, acme screw, oil lubricated, high efficiency, increased duty cycle up to 40% over a 10 minute period or 30% over a 1 hour period at 25°C environment temperature.

SJ Series: standard performances, acme screw, grease lubricated, increased duty cycle up to 30% over a 10 minute period or 20% over a 1 hour period at 25°C environment temperature

MA BS Series: travelling ball screw (Mod.A) or ball screw with travelling nut (Mod.B), oil lubricated, high performances and efficiency, increased duty cycle up to 100% at 25°C environment temperature.

SJ BS Series: ball screw with travelling nut (Mod.B), grease lubricated, increased duty cycle up to 70% at 25°C environment temperature.

Manufacturing features

SERVOMECH screw jacks are totally designed and manufactured inside the company with high technology and CNC machinery.

Quality System according to ISO 9001:2008, certified by TÜV.

Control tests are carried out in-line during manufacturing processes to monitor the production quality. Final control and functional check test are carried out to ensure the total quality and reliability of the final product.

Input drive: worm gear, high efficiency design, ZI involute profile, reduced axial backlash; bronze helical wormwheel EN 1982 – CuSn12-C; true involute worm in steel 20 MnCr 5 (UNI EN 10084), with hardened and ground thread and shaft.

Housing: monobloc housing designed for a more compact and robust shape, able to carry heavy loads and ensure a high precision level of machining. High resistance materials are used:

- casting in Aluminium alloy EN 1706 - AC-AISi10Mg T6
- casting in cast iron EN-GJL-250 (UNI EN 1561)
- casting in spheroidal graphite iron EN-GJS-500-7 (UNI EN 1563)
- casting in steel Fe G 60 (UNI 4010)

Materials and components

Acme screws, profile according to ISO 2901 ... ISO 2904

- material: steel C 43 (UNI 7847)
- subjected to straightening process to ensure the regular alignment in operation
- max. pitch error ± 0.05 mm over 300 mm thread length

Threaded bars available on stock:

ROLLED								
1 start	Tr 18x4	Tr 22x5	Tr 30x6	Tr 40x7	Tr 55x9	Tr 60x12	Tr 70x12	Tr 80x12
2 starts	Tr 18x8 (P4)	Tr 22x10 (P5)	Tr 30x12 (P6)	Tr 40x14 (P7)				

WHIRLED						
1 start	Tr 30x6	Tr 40x7	Tr 55x9	Tr 60x12	Tr 70x12	Tr 80x12
	Tr 90x12	Tr 100x12	Tr 100x16	Tr 120x14	Tr 140x14	Tr 160x16
2 starts	Tr 30x12 (P6)	Tr 40x14 (P7)	Tr 55x18 (P9)	Tr 60x24 (P12)	Tr 70x24 (P12)	Tr 80x24 (P12)
	Tr 90x24 (P12)	Tr 100x24 (P12)	Tr 100x32 (P16)	Tr 120x28 (P14)	Tr 140x28 (P14)	Tr 160x32 (P16)
3 starts	Tr 30x18 (P6)	Tr 40x21 (P7)	Tr 55x27 (P9)	Tr 60x36 (P12)	Tr 70x36 (P12)	Tr 100x48 (P16)
4 starts	Tr 30x24 (P6)	Tr 40x28 (P7)	Tr 55x36 (P9)	Tr 60x48 (P12)	Tr 70x48 (P12)	Tr 100x64 (P16)

Bronze travelling nut , profile according to ISO 2901 ... ISO 2904

- material: bronze nut with 1-start thread bronze EN 1982 - CuAl9-C
- bronze nut with multiple starts thread bronze EN 1982 - CuSn12-C
- max. axial backlash with new travelling nut: (0.10 ... 0.12) mm

Ball screws

- material: steel 42 CrMo 4 or 50 CrMo 4 (UNI EN 10083)

Threaded bars available on stock:

ROLLED, accuracy grade IT 7					
BS 14x5	BS 16x5	BS 20x5	BS 25x5	BS 32x5	BS 40x10
BS 14x10			BS 25x6	BS 32x10	BS 40x20
			BS 25x10	BS 32x20	BS 40x40

WHIRLED, accuracy grade IT 3 - IT 5							
BS 20x5	BS 25x6	BS 32x10	BS 40x10	BS 50x10	BS 63x10	BS 80x16	BS 100x16
BS 20x20	BS 25x10	BS 32x20	BS 40x20	BS 50x20	BS 63x20		
		BS 32x32	BS 40x40				

Ball nuts with flange DIN 69051 or with cylindrical flange

- material: steel 18 NiCrMo 5 (UNI EN 10084)

Ball nuts with ZERO backlash or preloaded

Threaded shafts with machined ends and nuts at customer's drawing available on request.

Screw jacks

Acme screw jacks

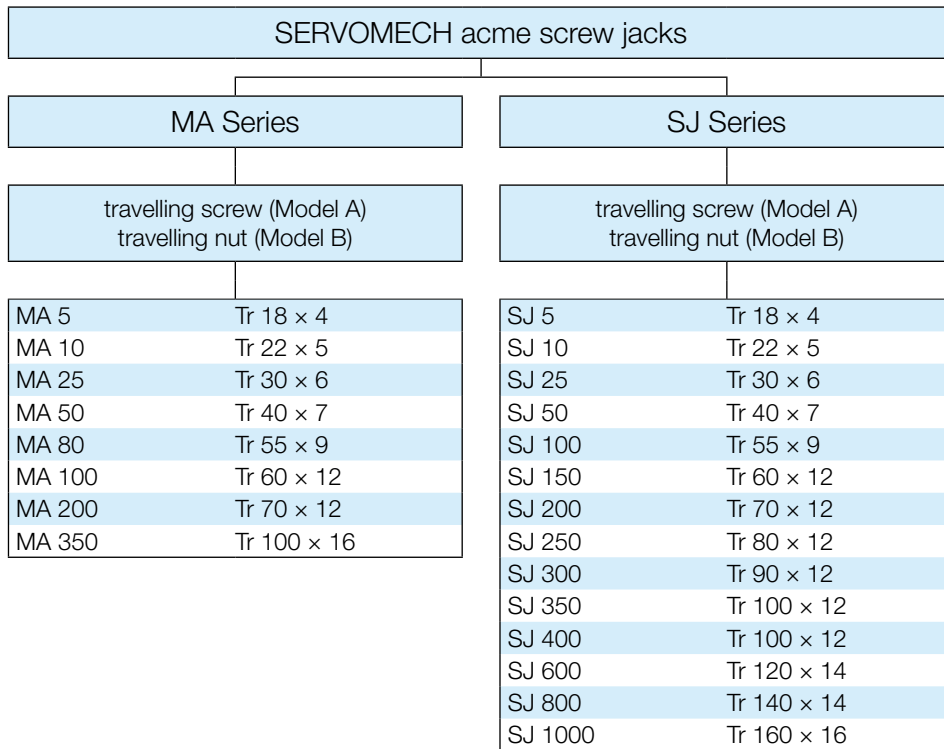

MA Series: high efficiency screw jacks	SJ Series: standard performances screw jacks
8 standard sizes with load capacity from 5 kN to 350 kN	14 standard sizes with load capacity from 5 kN to 1 000 kN
Model A: travelling screw Model B: travelling nut	
1- start acme screw from Tr 18 × 4 to Tr 100 × 16	1- start acme screw from Tr 18 × 4 to Tr 160 × 16
2-starts acme screw from Tr 18 × 8 (P4) to Tr 100 × 32 (P16)	2-starts acme screw from Tr 18 × 8 (P4) to Tr 160 × 32 (P16)
Screw jacks MA Series Model A with travelling screw: 3- or 4-starts acme screws available	
6 different input versions for each size and ratio Vers.1: single input shaft Vers.2: double free input shaft Vers.3: flange and hollow shaft input for IEC motor Vers.4: flange and hollow shaft input for IEC motor with second free input shaft Vers.5: Vers.1 + bell housing and coupling for IEC motor Vers.6: Vers.2 + bell housing and coupling for IEC motor	
long-life synthetic oil lubricated worm gear	long-life synthetic grease lubricated worm gear
operation with low noise level with input speed up to 3 000 rpm	max. input speed allowed 1 500 rpm
suitable for high linear speed and high duty cycle applications	competitive in industrial applications price/performance : excellent ratio
wide range of accessories available	

Ball screw jacks

SERVOMECH ball screw jacks		
MA BS Series		SJ BS Series
travelling ball screw (Model A)		travelling ball nut (Model B)
MA 5	BS 14×5 BS 16×5	MA 5 BS 20×5 BS 25×6
MA 10	BS 16×5 BS 20×5	MA 10 BS 25×6 BS 32×5
MA 25	BS 32×10; BS 32×20; BS 32×32	MA 25 BS 32×5; BS 32×10; BS 32×20; BS 32×32
MA 50	BS 40×10; BS 40×20; BS 40×40	MA 50 BS 40×10; BS 40×20; BS 40×40
		MA 80 BS 50×10; BS 50×20
MA 100	BS 50×10; BS 50×20; BS 63×10; BS 63×20	MA 100 BS 63×10; BS 63×20
MA 200	BS 80×16	MA 200 BS 80×16 BS 100×16
MA 350	BS 100×16	MA 350 BS 100×16
		SJ 5 BS 20×5 BS 25×6
		SJ 10 BS 25×6 BS 32×5
		SJ 25 BS 32×5; BS 32×10; BS 32×20
		SJ 50 BS 40×10; BS 40×20
		SJ 100 BS 50×10; BS 50×20
		SJ 150 BS 63×10; BS 63×20
		SJ 200 BS 80×16
		SJ 250 BS 100×16

MA BS Series:	SJ BS Series:
high efficiency screw jacks, suitable for continuous operation also, duty cycle up to 100 %, input speed up to 3 000 rpm	standard performances screw jacks, Model B (travelling nut) available only, duty cycle up to 70 %, input speed up to 1 500 rpm
8 standard sizes with load capacity from 5 kN to 350 kN	8 standard sizes with load capacity from 5 kN to 250 kN
Model A: travelling ball screw Model B: travelling ball nut	Model B: travelling ball nut
ball screw from BS 14 × 5 to BS 100 × 16	ball screw from BS 20 × 5 to BS 100 × 16
6 different input versions for each size and ratio Vers.1: single input shaft Vers.2: double free input shaft Vers.3: flange and hollow shaft input for IEC motor Vers.4: flange and hollow shaft input for IEC motor with second free input shaft Vers.5: Vers.1 + bell housing and coupling for IEC motor Vers.6: Vers.2 + bell housing and coupling for IEC motor	
long-life synthetic oil lubricated worm gear	long-life synthetic grease lubricated worm gear
wide range of accessories available	

NOTE: Performances, features and dimensions of ball screw jacks and ball screws are quoted in the specific catalogues:

- catalogue **Ball screw jacks**,
- catalogue **Ball screws and nuts**.

Screw jacks

Models

Both MA and SJ Series screw jacks are available in two models:

with travelling screw (Model A)

with travelling nut (Model B)

The choice of the model depends on the configuration and requirements of the application. The performances are in general the same for both models.

SERVOMECH screw jacks can be operated in vertical or horizontal planes, or angles in-between. Input options available: free shaft, double free shaft, motor flange with or without second shaft.

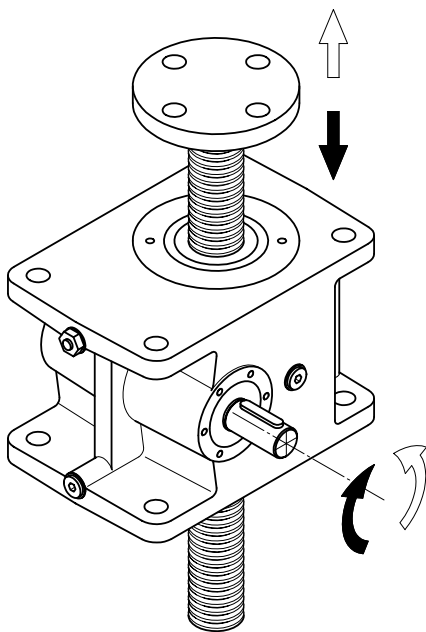

travelling ball screw (Model A)

The bronze nut is integral with the worm wheel.

The linear motion is given by the acme screw being driven through the centre of the worm wheel. In operation, the screw does not rotate. Space must be available on both screw jacks sides for the screw to protrude below the gear housing.

Options:

- protective tube
- protective bellows
- safety bronze nut
- various screw end fixings
- stroke end switches
- anti-turn device
- wear indicator switch
- adjustable backlash
- stop nut
- trunnion mounting
- stainless steel acme screw
- bronze guides

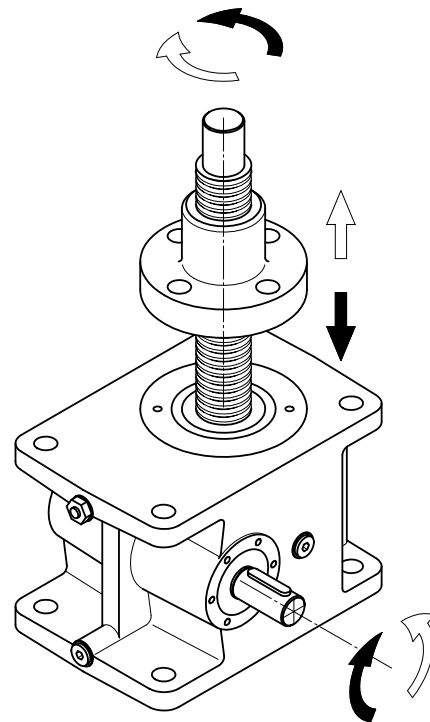

travelling ball nut (Model B)

The acme screw is fixed to the worm wheel. In operation the screw rotates with the worm wheel at the same speed, driving the bronze nut up and down. The linear motion of the nut is possible only if the reacting torque is applied, avoiding the integral rotation with the acme screw.

Options:

- protective bellows
- safety bronze nut
- wear indicator switch
- adjustable backlash
- stainless steel acme screw
- trunnion mounting travelling nut
- travelling nut at customer's drawing

Screw jacks

Versions

INPUT SHAFT ROTATION – SCREW OR NUT LIFTING DIRECTION

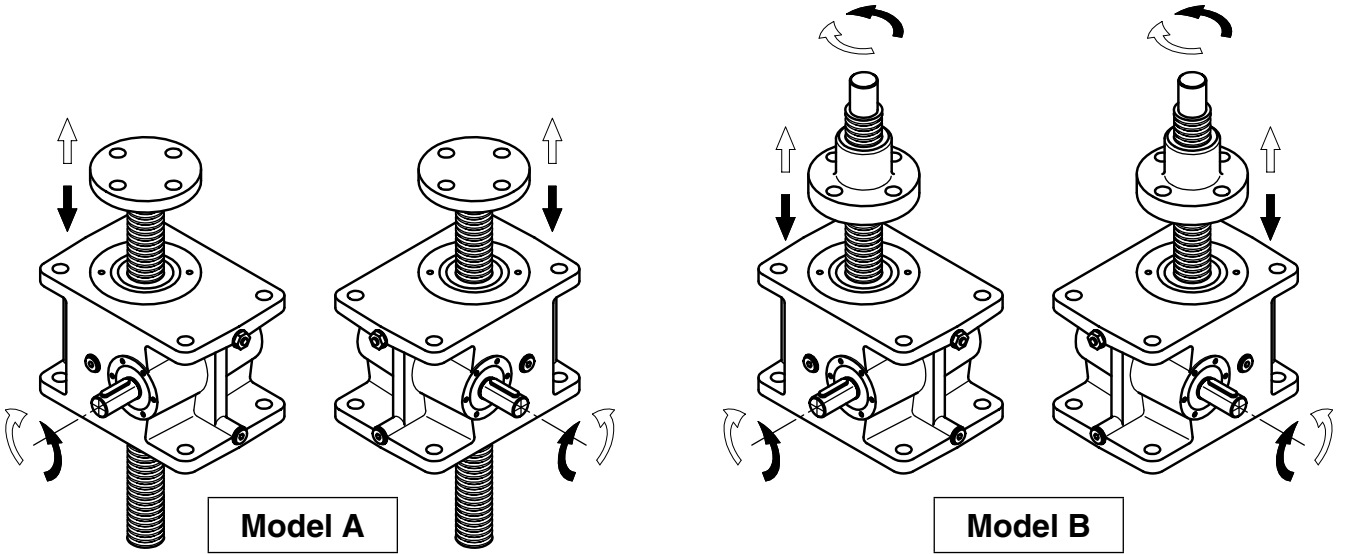

INPUT VERSIONS

Vers.1	Vers.2	Vers.3	Vers.4	Vers.5	Vers.6

Vers.1: single input shaft

Vers.2: double free input shaft

Vers.3: flange and hollow shaft input for IEC motor

Vers.4: flange and hollow shaft input for IEC motor with second free input shaft

Vers.5: Vers.1 + bell housing and coupling for IEC motor

Vers.6: Vers.2 + bell housing and coupling for IEC motor

SCREW JACK MOUNTING POSITIONS

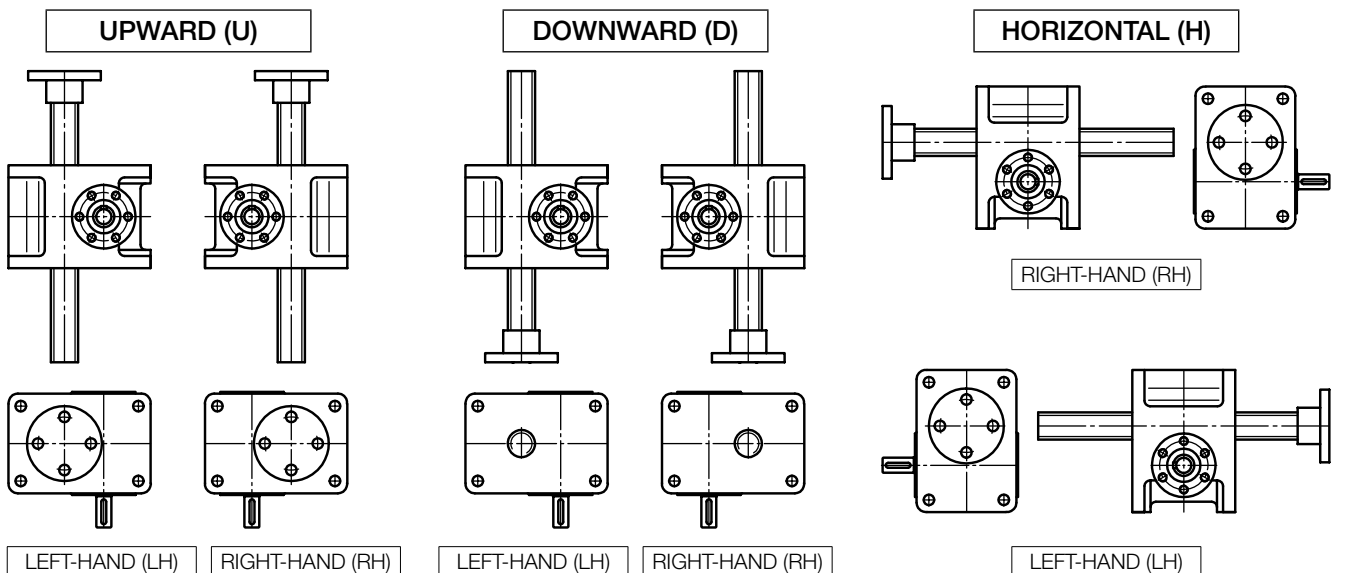

Screw jacks selection criteria

Screw jacks transform a rotary movement into a linear movement. Due to the screw-nut efficiency, this transformation implies a loss of energy depending on the screw and the nut type which is in inverse relation to their efficiency. Therefore, the energy loss is higher with 1-start acme screw and nut when compared with 2- or more starts acme screw and nut.

Therefore to select the right screw jack suitable for an application, it is necessary to consider the duty cycle required by the application F_u [%] and compare it to the duty cycle that the screw jack can perform F_i [%].

The **application duty cycle F_u [%] required** is the ratio between the working time under load required by the application during a reference time period and the reference time period itself, expressed in percentage.

$$F_u [\%] = \frac{\text{Working time during reference time period } T_{rif} [\text{min}]}{\text{Reference time period } T_{rif} [\text{min}]} \times 100$$

T_{rif} - reference time period, expressed in minutes:

$T_{ref} = 10$ minutes for short, but frequent working cycles

$T_{ref} = 1$ hour (60 min) for long, but infrequent working cycles

The **screw jack duty cycle F_i [%] allowed** is the percentage of time referred to the reference time period T_{ref} during which the screw jack can operate under maximum load conditions - stated in this catalogue - at 25°C environment temperature, to avoid the risk of internal parts overheating. Therefore, the main limit to the working time of screw jacks is often due to the thermal power limits and not to the maximum permissible operating mechanical power.

The screw jack duty cycle F_i [%] is related to the maximum permissible power. If the power required by the application is lower than the maximum permissible power, than the screw jack can be used with a higher duty cycle.

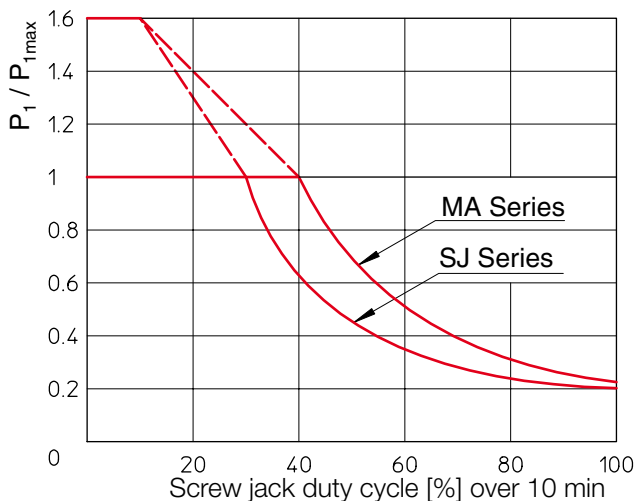

P_1 - Power required by the application
 P_{1max} - Screw jack's max permissible power (see performances tables)

If the environment temperature is higher than 25°C, the screw jack duty cycle F_i [%] has to be reduced by applying a correction factor f_T as per the following formula:

$$f_T = \frac{80 - T [^{\circ}\text{C}]}{55}$$

where:

$T [^{\circ}\text{C}]$ - environment temperature, expressed in degree Celsius

If the environment temperature increases, the permissible duty cycle of the screw jack F_i [%] is reduced.

In order to make a correct screw jack selection, we recommend the following selection procedure:

1. Model:

- Model A – travelling screw
- Model B – travelling nut

2. SERVOMECH screw jack series:

- MA Series: high efficiency screw jack with acme screw, oil lubricated
- SJ Series: standard performances screw jack with acme screw, grease lubricated

3. Screw jack size:

- Pull or push load
- Stroke
- Linear speed
- Power required

4. Input version:

- Vers.1: single free input shaft
- Vers.2: double free input shaft
- Vers.3: flange and hollow shaft input for IEC motor
- Vers.4: flange and hollow shaft input for IEC motor with second free input shaft
- Vers.5: Vers.1 + bell housing and coupling for IEC motor
- Vers.6: Vers.2 + bell housing and coupling for IEC motor

5. Screw jack mounting position:

- Upward U
- Downward D
- Horizontal H
- Right-hand RH
- Left-hand LH

6. Accessories required

Screw jack selection

The screw jack selection is the last step of a more complex global lifting-system selection procedure, where the overall dimensions and safety requirements of the application have to be considered as an integral part of that selection. In this section we only focus on a single screw jack selection. You will find more exhaustive comments and recommendations on the screw jacks complete lifting system chapter.

1. Screw jack model selection: all SERVOMECH screw jacks versions and sizes are available in two different models:

- Model A – travelling screw
- Model B – travelling nut

The choice between the two different models only depends on the configuration and mounting details of the application.

In case of Model B (rotating screw and external translating nut) selection, we recommend to pay attention to the following:

- screw and nut lubrication
- acme screw protection
- only axial load can be applied on the translating nut referred to the rotating acme screw axis
- rotating screw end, especially in case of long stroke length and push load
- off-set or radial load applied on the nut may lead to dangerous misalignment between screw and nut, so it is not permitted. If present, it must be supported by an appropriate, suitable solution.

Screw jacks

2. SERVOMECH screw jacks series:

The screw jack's duty cycle and the duty cycle required by the application F_u [%] are the most important factors in choosing between the two available screw jacks series, as previously described.

The duty cycle required by the application F_u [%] has to be lower than or equal to the working duty cycle rating the screw jack can perform F_i [%], inclusive the environment temperature correction factor (f_T):

$$F_u \text{ [%]} \leq F_i \text{ [%]}$$

Here below are values of the max. duty cycle F_i [%] at 25°C environment temperature for the SERVOMECH screw jacks series:

Duty cycle allowed F_i [%]	MA Series	SJ Series
F_i [%] over 10 min time period	40 %	30 %
F_i [%] over 1 hour time period	30 %	20 %

Lifting Systems

Usually, a screw jack lifting system is composed of several lifting points (see examples on pages 94 - 95).

Screw jack's position and number depend on application requirements as:

- dimension and surface of the platform or plane
- required stroke length
- total lifting load (dynamic load)
- lifting system configuration, guided or not guided load

Furthermore, specific application project requirements may also influence the selection.

A new lifting system project can be very complex and therefore it requires the clever evaluation of many different technical and application details, in order to provide a functional, safe and competitive solution.

Here are some suggestions that can help the lifting system's designer on his project evaluations.

Static safety: Firstly, the required or desired safety level has to be considered. On screw jack product, there are no regulations on the matter of safety standards and technical data declared on catalogue. Many manufacturers do not use the same safety factors on their technical calculations and also the materials may be different.

We recommend a full evaluation of all screw jack components. Dimensions, outer diameter and lead of screw thread are not enough for a complete evaluation. It is also important to evaluate the worm gear in terms of:

- centre distance, overall dimensions and total weight
- axial bearings: type and size
- nut: material and dimensions

Norms and rules: In case, be sure to consider all norms and rules which the project must comply with. This can significantly affect the final solution.

Noise and vibrations: For applications which require a low and controlled noise level, we recommend a solution which allows, with same final performances, a lower input speed for the connecting shaft.

This will help to reduce or eliminate also vibrations or dangerous input speeds for the connecting shafts.

Example: lifting stages for theatres, lecture or concert hall:

- motor speed reduced to max. (300 ... 400) rpm
- use of bevel gearboxes with ratio 1 : 1
- balanced connecting shafts, well aligned and supported, max. non-supported length (2 ... 3) m
- SERVOMECH screw jacks with ratio RV (high linear speed) and multiplied starts acme screw

Hanging load: Auxiliary safety nuts are available to comply with norms and rules about hanged loads with presence of personnel for maintenance.

Self-locking: Generally, the statically self-locking condition of the lifting system can be achieved by using a 1-start acme screw jack. Sometimes, to comply with some norms and rules, a certain mechanical self-locking condition can only be achieved by a lower than 4° helix angle acme screw with a lead smaller than the standard. Those special executions are available on request.

Positioning (stopping) accuracy: The positioning (stopping) accuracy can be achieved by using brake-motors or frequency inverters to control speed and acceleration and deceleration ramps, especially in case of downward moving loads.

Operating safety: Different safety devices can also be considered or requested for the application:

- mechanical safety: safety nut, mechanical stop of the load;
- electric or electronic safety: wear control of the working nut to check the distance between working and safety nut; speed control of the connecting shaft; rotation detection of the worm wheel; control of max. power or current required for the lifting system.

Load inertia: If the load has to be rapidly accelerated or decelerated, in applications with high linear speed, we recommend to use an appropriate drive to control the acceleration and deceleration ramps (for example, frequency inverter for AC 3-phase motors or double polarity motors and soft-start devices).

Guided load: In case of applications with large dimensions, high loads and long strokes, we recommend to evaluate the possibility to guide the load.

If the load is guided, a smaller screw diameter may be selected and consequently a cheaper screw jacks can be used, whilst maintaining the same functionality and static load capability.

This means a cost effective final solution for the project.

Screw jacks with increased acme screw diameter, if the static resistance is more significant than the dynamic application conditions for lifting systems:

- long stroke with medium static push load
- medium strokes with high static push load

SERVOMECH screw jacks with increased diameter acme screw are available to offer a more cost effective solution.

For assistance in selecting lifting systems and linear motion devices, SERVOMECH Engineering Dpt. is available to support you free of charge.

Screw jacks

Self-locking

An acme screw jack is in self-locking condition when:

- a push or pull load applied on a not working screw jack does not start the linear movement (static self-locking condition);
- by interrupting the motor power supply of a working screw jack with push or pull load, the movement stops (dynamic self-locking condition).

Self-locking and **back-driving** conditions are defined in the following 4 situations:

- 1) **Static self-locking:** not running screw jack without load vibrations; the application of a push or pull force (until the maximum allowed) does not cause the linear movement of the acme screw (Model A) or of the travelling bronze nut (Model B).

This condition happens when the direct efficiency value¹⁾ is lower than 0.30.

- 2) **Dynamic self-locking:**

- Working screw jack with a load opposite the motion: by interrupting the motor power supply the screw jack stops.

This condition happens when the direct efficiency value¹⁾ is lower than 0.25.

- Working screw jack with a load applied on the same direction of the motion: the screw jack's stop is not guaranteed by interrupting the motor power supply. The screw jack stops only if the direct efficiency value¹⁾ is lower than 0.20 and, anyway, it stops in an unrepeatable position.

In this case, we recommend to use a brake motor to stop the load and keep it in position, avoiding the motion start in case of pushes or vibrations.

- 3) **Uncertain self-locking:** with direct efficiency values¹⁾ between 0.30 and 0.50, the screw jacks are in an uncertain self-locking condition. The self-locking depends on the load and the inertia of the system.

In this case we recommend to use a brake motor to guarantee the self-locking condition or to contact SERVOMECH Engineering Dpt. to evaluate the application.

- 4) **Back-driving:** screw jacks with direct efficiency value¹⁾ higher than 0.50 are never self-locking.

We remind you that, in any case, also to start a not self-locking screw jack a certain minimum load must be applied. To define this load value please contact SERVOMECH Engineering Dpt.

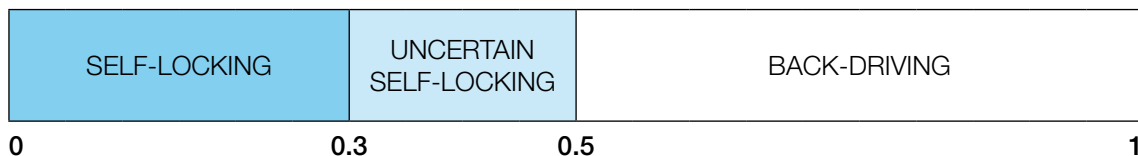

¹⁾ The direct efficiency values are shown in the relative tables (see pages 36, 61 and 67).

Acme screw buckling

One of the main screw jack selection factors is the buckling resistance of the acme screw. Buckling limits are relevant for push load only.

There are three cases:

- Euler I screw jack housing firmly fixed to the base – free acme screw end
- Euler II screw jack housing and acme screw end fixed to pivoting supports
- Euler III screw jack housing firmly fixed to the base – guided acme screw end

Following diagrams (known as Euler curves) show the max. push load admitted on the acme screw, considering a safety factor against buckling equal to 4.

For more accurate evaluation in case of particular application requirements, critical for safety reasons (e.g. theatre lifts), contact SERVOMECH Engineering Dpt.

Euler I - screw jack housing firmly fixed to the base - free acme screw end

Example: To suit a push load of 60 kN applied on an acme screw 1 000 mm long, the right screw size is Tr 70×12 mounted on a screw jack MA 200 or SJ 200.

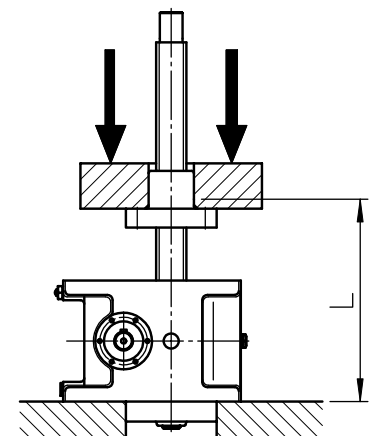
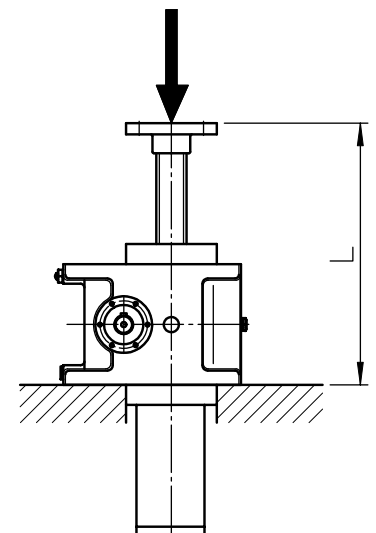
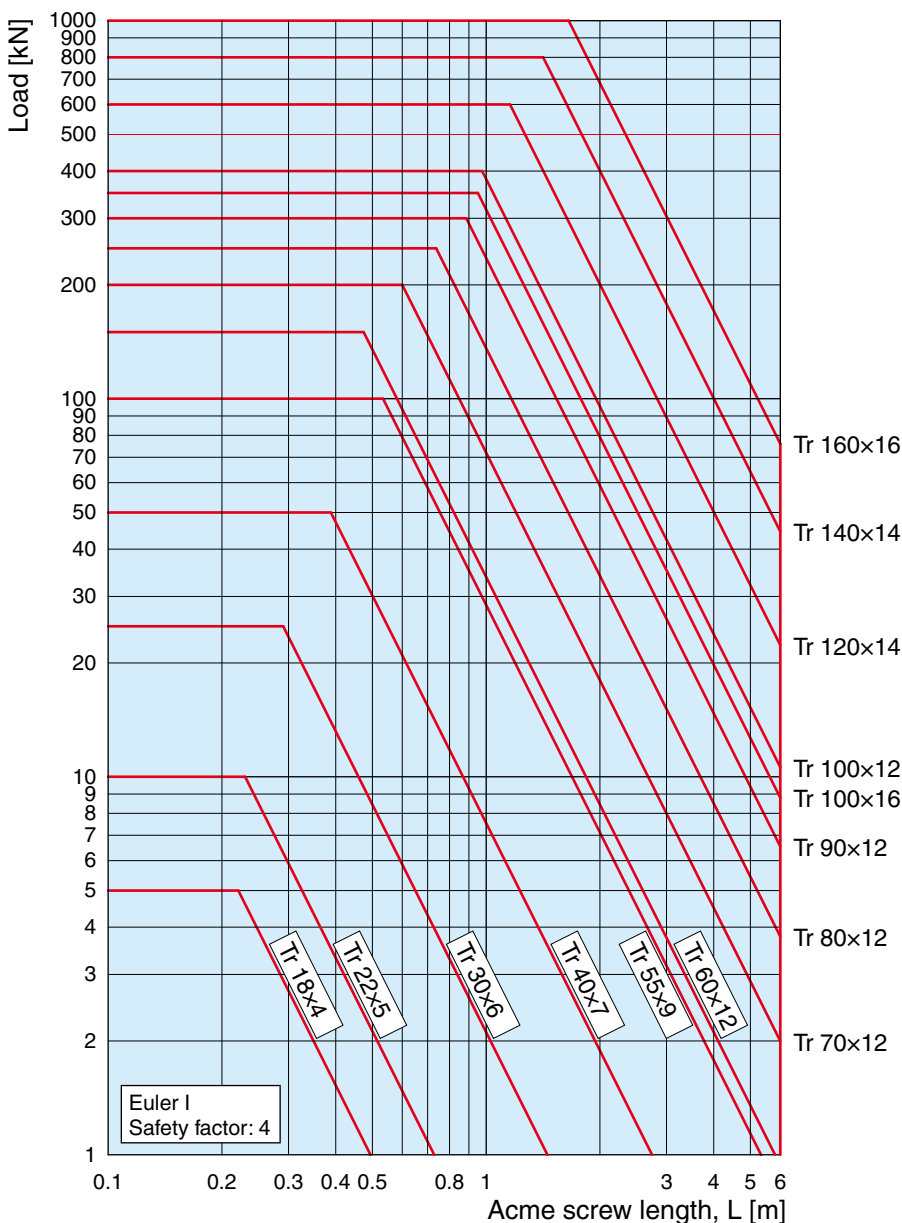

Screw jacks

Acme screw buckling

Euler II - screw jack housing and acme screw end fixed to pivoting supports

Example: To suit a push load of 20 kN applied on an acme screw 1 000 mm long, the right screw size is Tr 40x7 mounted on a screw jack MA 50 or SJ 50.

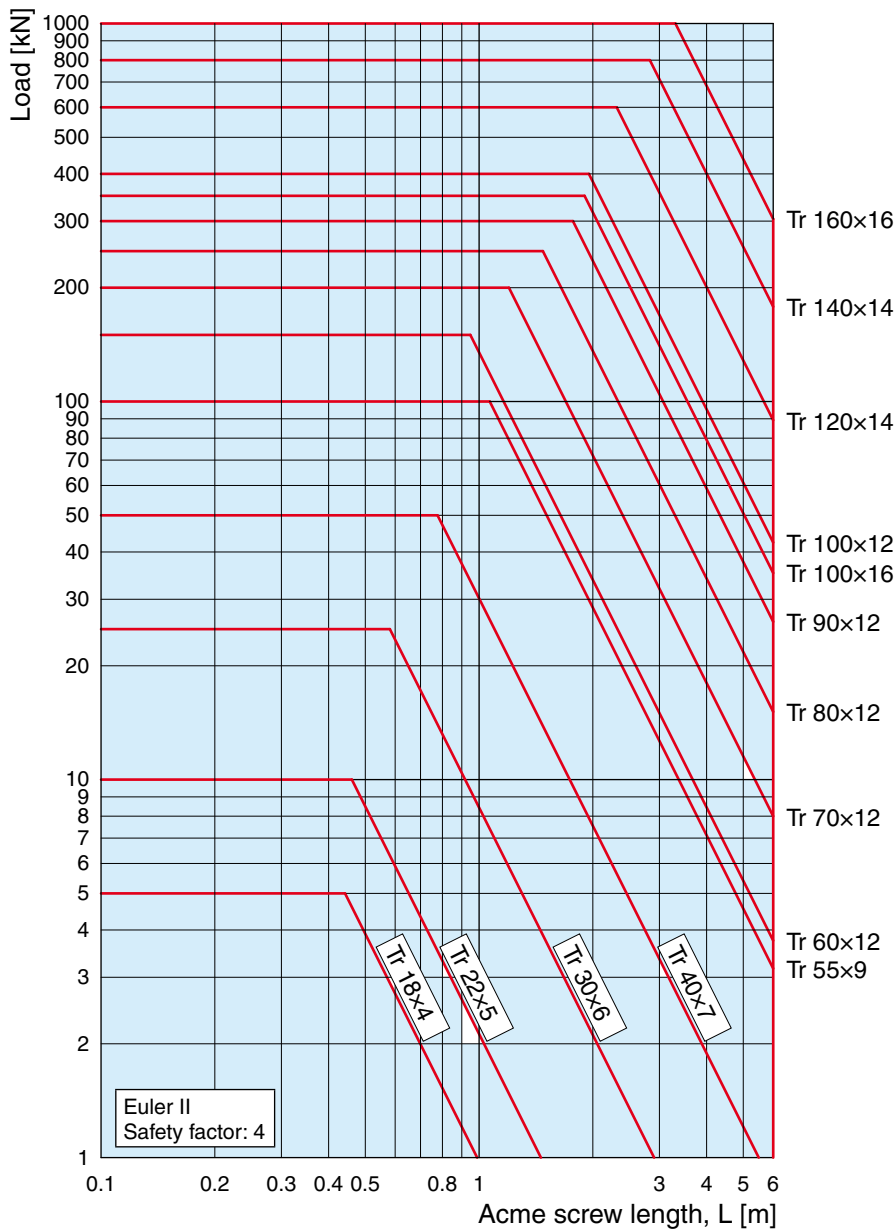
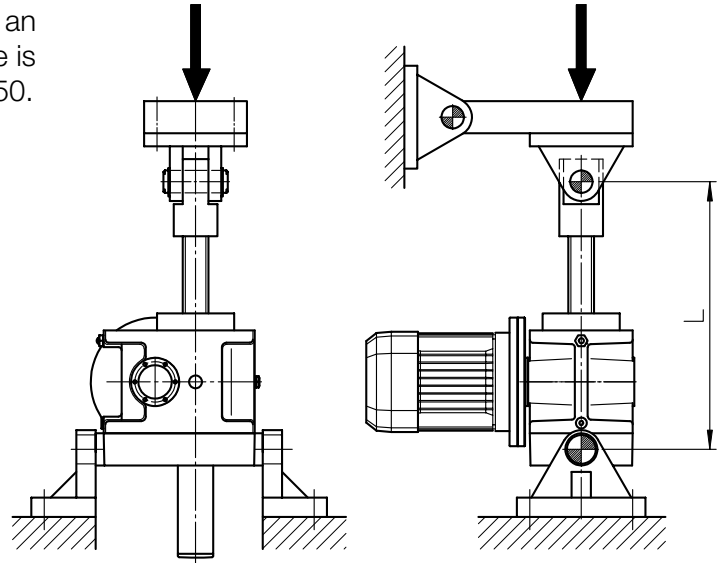

Screw jacks

Acme screw buckling

Euler III - screw jack housing firmly fixed to the base - guided acme screw end

Example: To suit a push load of 100 kN applied on an acme screw 3 000 mm long, the right screw size is Tr 80×12 mounted on a screw jack SJ 250.

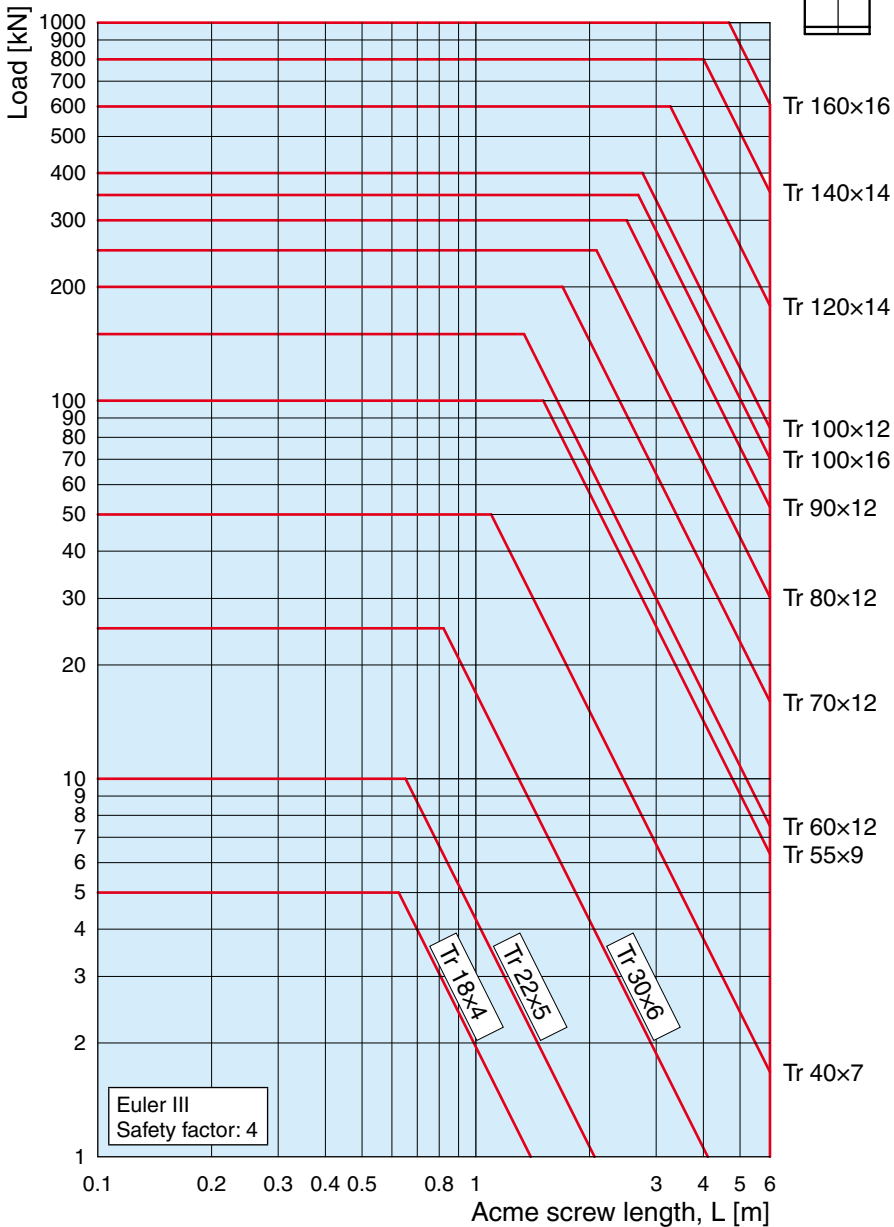
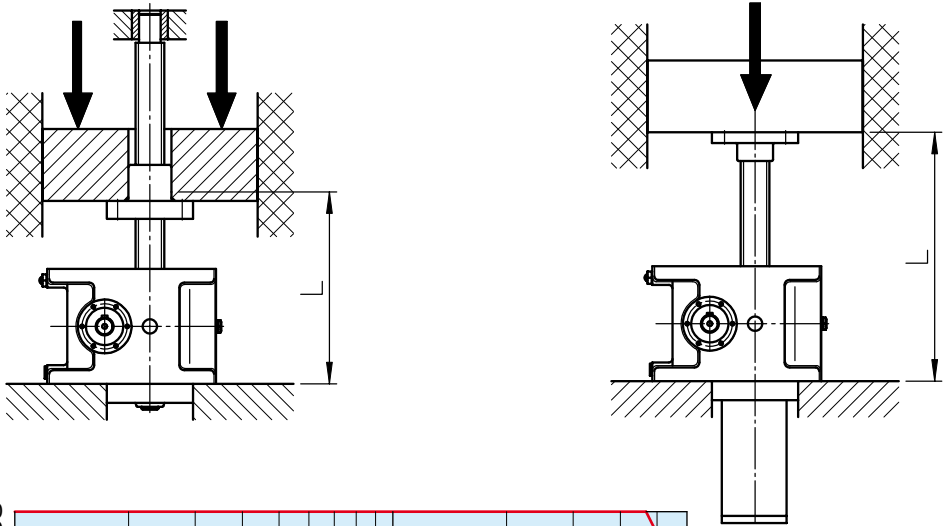

Screw jacks

Critical rotating speed of acme screw

For travelling nut (Model B) screw jacks, the acme screw rotating speed must not reach the first critical speed of the screw itself, which depends on the thread diameter and lead, screw length and type of the screw end support.

Free acme screw end

Example: For a screw jack SJ 150 with acme screw Tr 60x12 (1-start or more) 2 m long with free end, the max. allowed rotating speed is 420 rpm. With a 1-start thread, this rotating speed is equivalent to a linear speed of 85 mm/s.

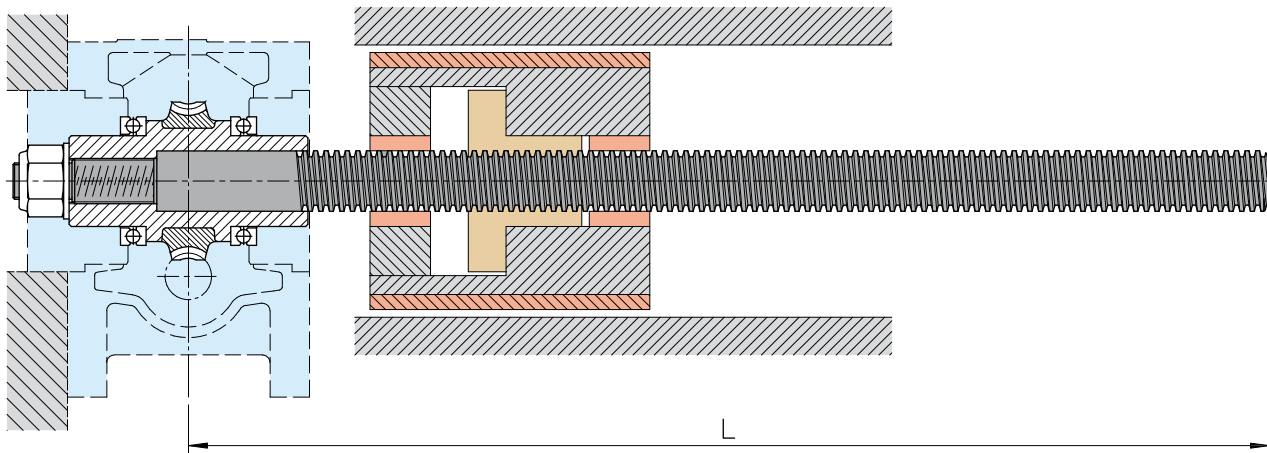

$$n_{\max} = 392 \cdot 10^5 \cdot \frac{0.9 \cdot d_{\min}}{L^2}$$

d_{\min} [mm] - min. thread diameter
 (for a thread Tr d x P: $d_{\min} = d - P$)
 L [mm] - acme screw length

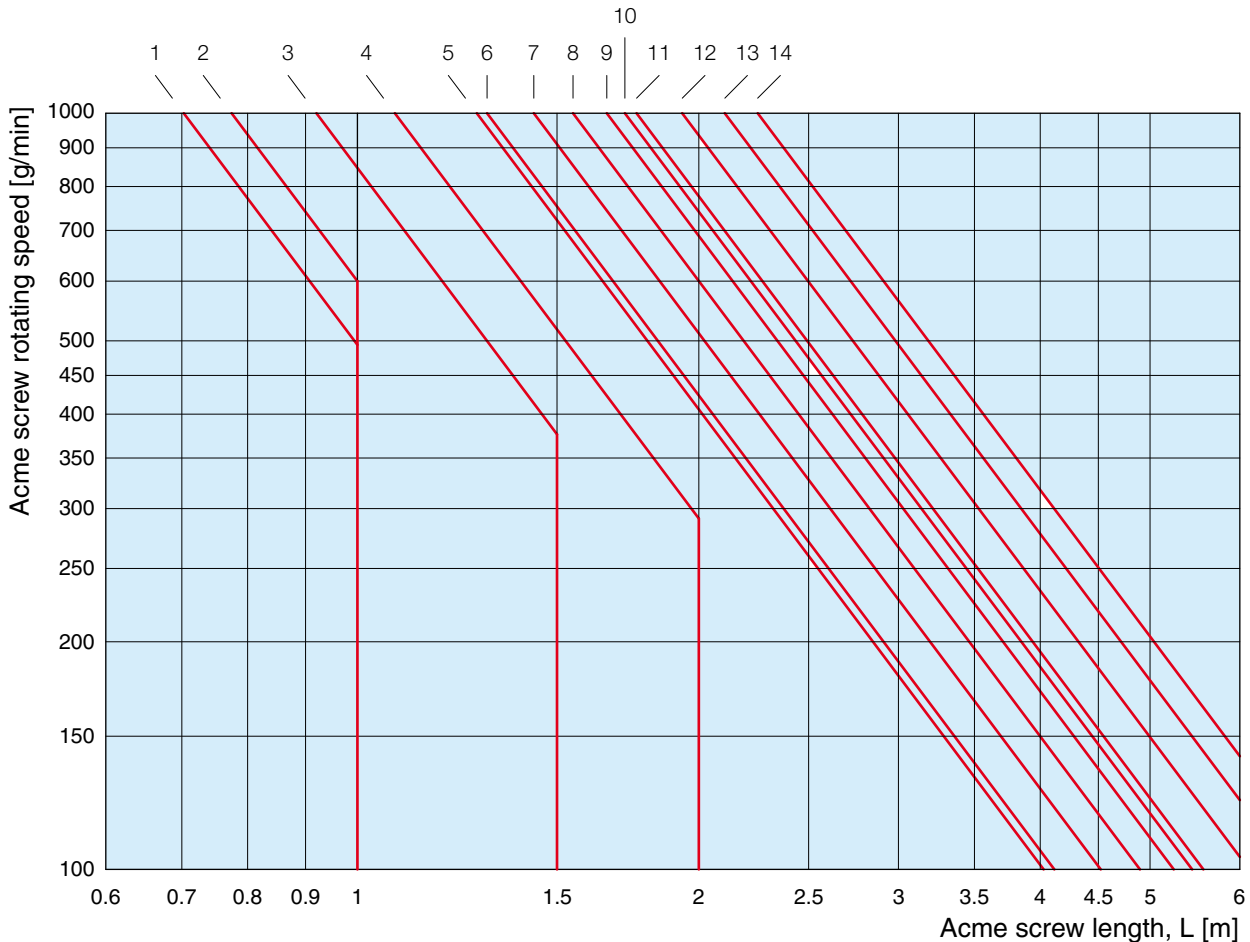

1 - Tr 18x4	4 - Tr 40x7	7 - Tr 70x12	10 - Tr 100x16	13 - Tr 140x14
2 - Tr 22x5	5 - Tr 55x9	8 - Tr 80x12	11 - Tr 100x12	14 - Tr 160x16
3 - Tr 30x6	6 - Tr 60x12	9 - Tr 90x12	12 - Tr 120x14	

ATTENTION! In case of horizontal mounting, an acme screw static deflection, caused by its weight and possibly aggravated by the presence of the push load, should always be considered. Therefore, we recommend an accurate evaluation and use of a screw supporting system on two nut sides, integral and travelling with the nut itself; this will ensure the correct alignment and concentricity between the screw and the nut. In case of doubts, please contact SERVOMECH Engineering Dpt.

Supported acme screw end

Example: For a screw jack MA 50 with acme screw Tr 40×7 (1-start or more) 3 m long with supported end, max. allowed rotating speed is 550 rpm. With a 1-start thread, this rotating speed is equivalent to a linear speed of 64 mm/s.

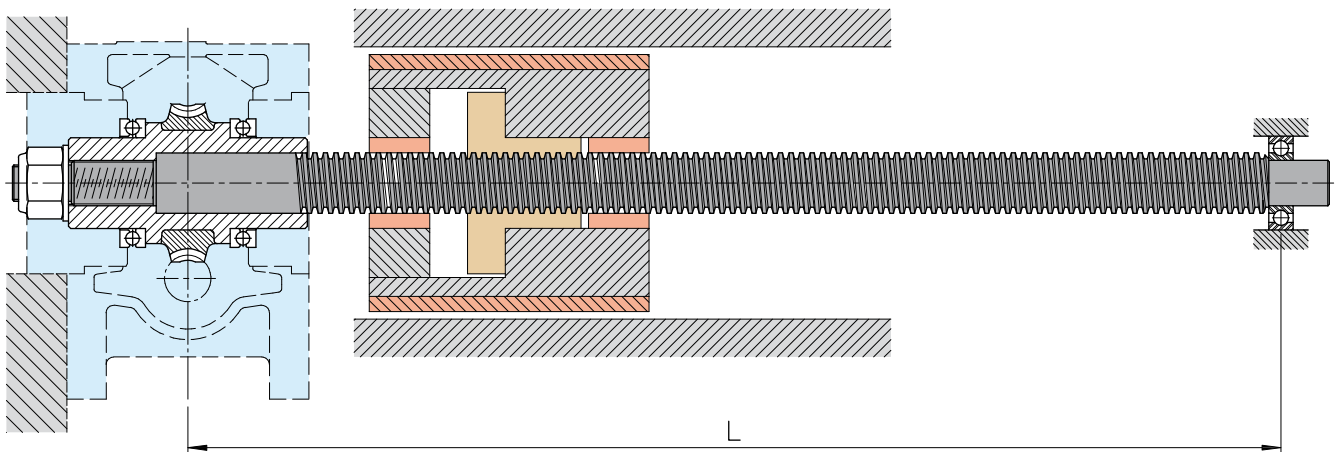

$$n_{\max} = 392 \cdot 10^5 \cdot \frac{3.8 \cdot d_{\min}}{L^2}$$

d_{\min} [mm] - min. thread diameter
(for a thread Tr $d \times P$: $d_{\min} = d - P$)
 L [mm] - acme screw length

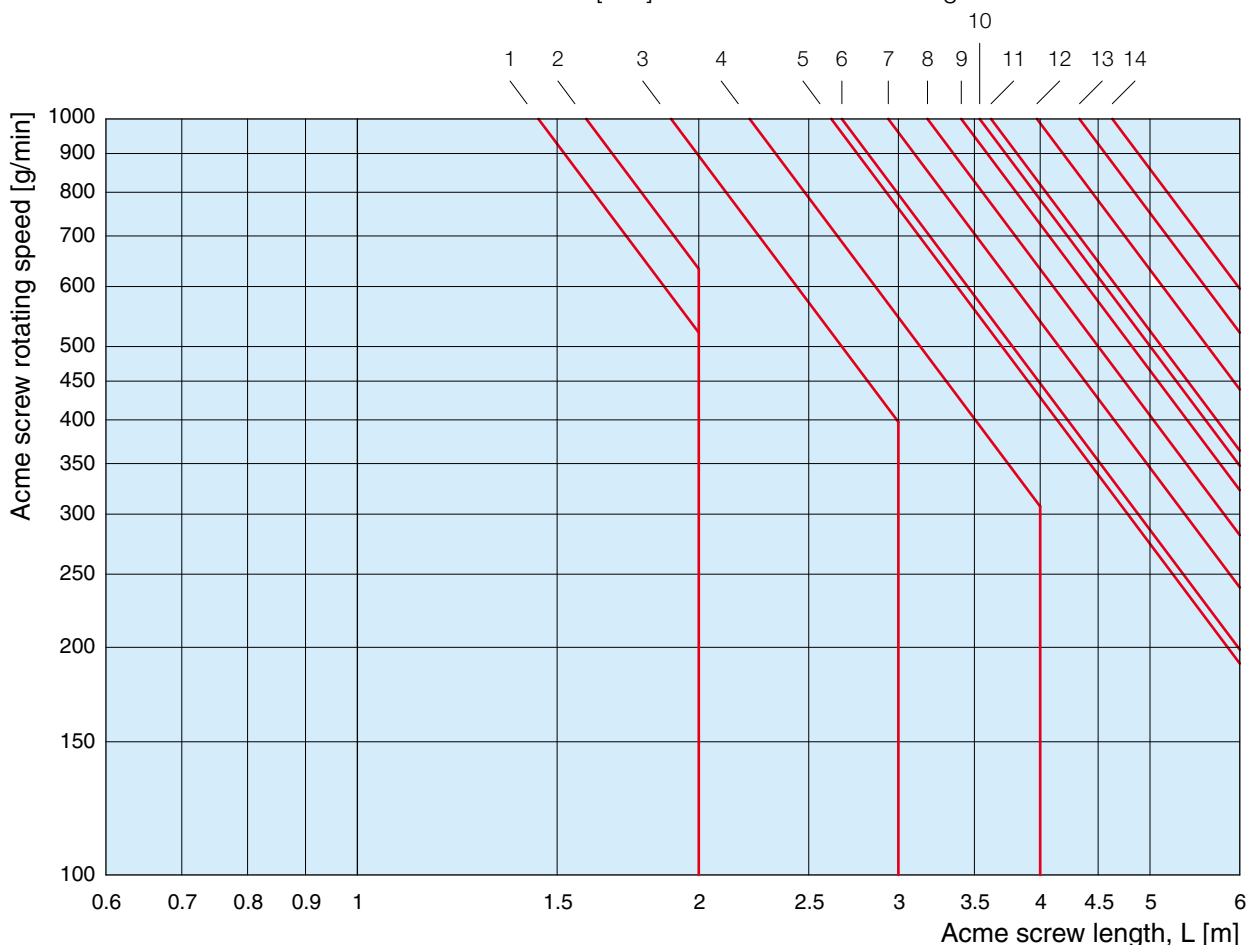

1 - Tr 18×4	4 - Tr 40×7	7 - Tr 70×12	10 - Tr 100×16	13 - Tr 140×14
2 - Tr 22×5	5 - Tr 55×9	8 - Tr 80×12	11 - Tr 100×12	14 - Tr 160×16
3 - Tr 30×6	6 - Tr 60×12	9 - Tr 90×12	12 - Tr 120×14	

Screw jacks MA Series

Screw jacks MA Series with travelling screw (Mod.A) STRUCTURAL ELEMENTS

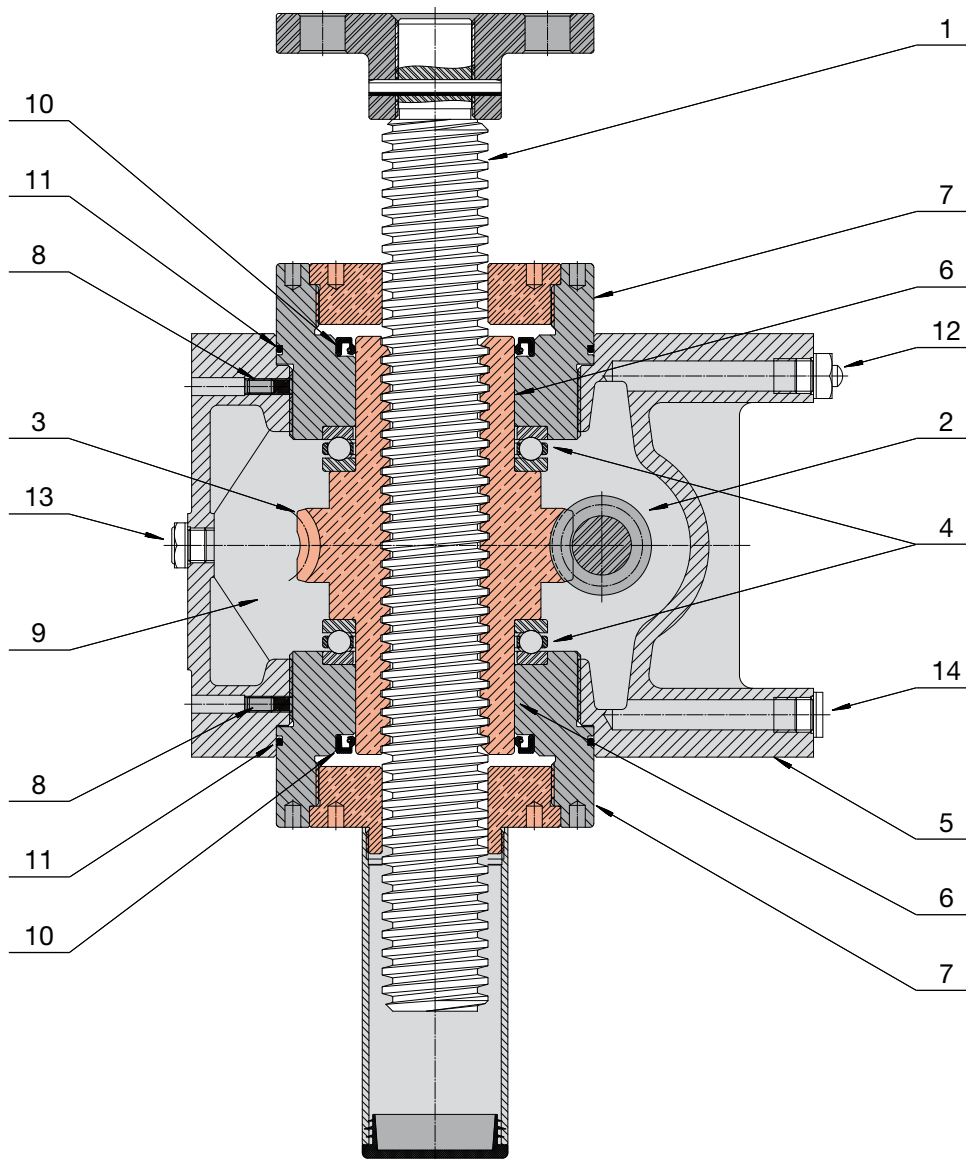

2

- 1 - acme screw in steel C 43 (UNI 7847), whirled thread
- 2 - worm shaft with true involute, ground worm profile ZI (UNI 4760), made in steel, case-hardened
- 3 - bronze wormwheel with true involute profile ZI (UNI 4760), the length of the internal nut is double respect to SJ Series; the bigger mass of the bronze nut allows a higher duty cycle and a longer life
- 4 - thrust ball bearing for high load capacity
- 5 - gear box shape which allows effective heat dissipation giving increased duty cycle
- 6 - radial guide of the wormwheel for increased stiffness and improved efficiency
- 7 - raised cover with bronze guide against radial load for acme screw; the raised cover may also be used as a spigot diameter
- 8 - grub screw which prevents the threaded cover unscrewing
- 9 - synthetic oil lubricated worm gearbox for a better heat dissipation; this allows higher input speed, improved efficiency and longer life
- 10 - radial lubricant seal
- 11 - O-Ring as lubricant seal
- 12 - breather
- 13 - oil level plug
- 14 - oil drain plug

Screw jacks MA Series

Screw jacks MA Series with travelling nut (Mod.B) STRUCTURAL ELEMENTS

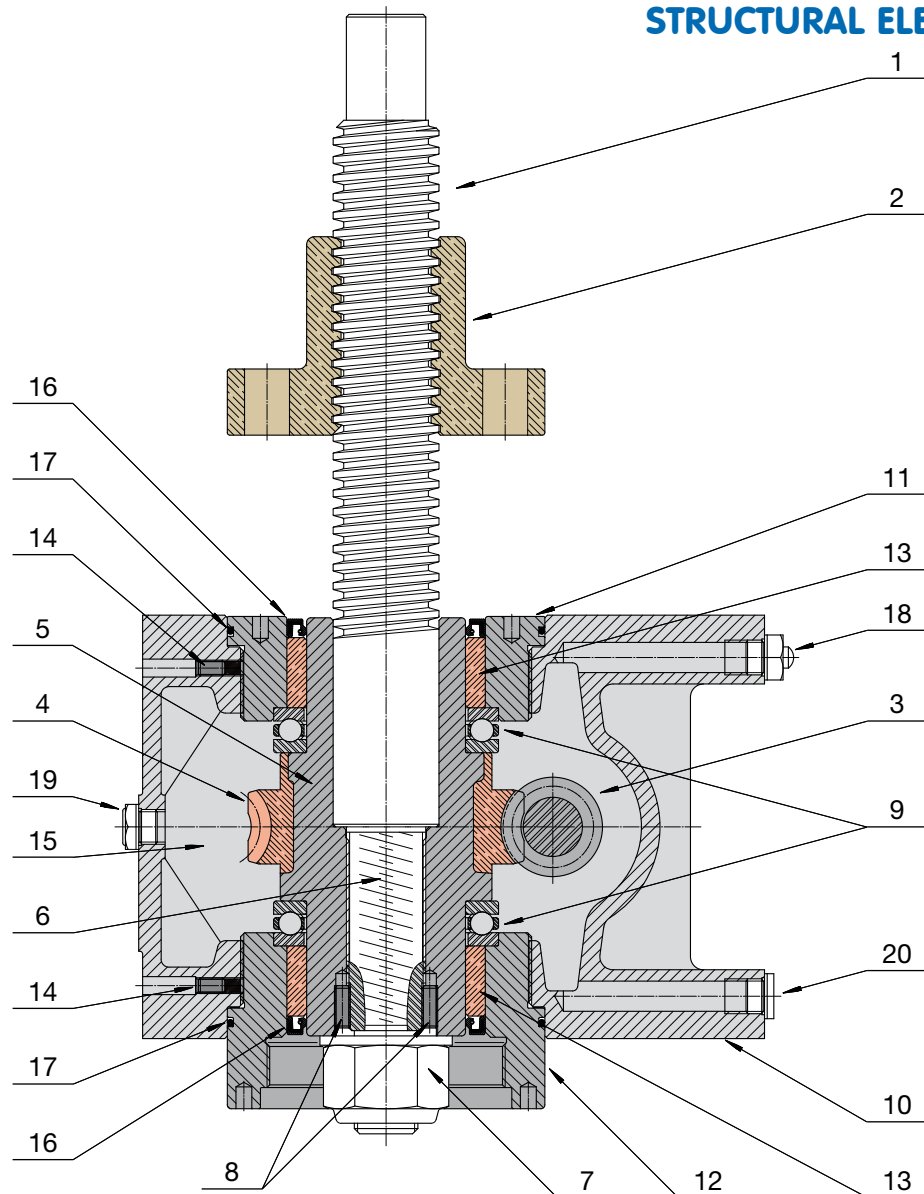

2

- 1 - acme screw in steel C 43 (UNI 7847), whirled thread
- 2 - bronze travelling nut with flange
- 3 - worm shaft with true involute, ground worm profile ZI (UNI 4760), made in steel, case-hardened
- 4 - bronze wormwheel with true involute profile ZI (UNI 4760)
- 5 - cast iron support of the wormwheel bronze rim
- 6 - acme screw fixed to the wormwheel through the cylindrical centring part and LEFT-HAND (for push load) or RIGHT-HAND (for pull load) metric thread
- 7 - lock nut with the opposite direction metric thread to ensure safe acme screw fixing
- 8 - acme screw – wormwheel pins against unscrewing
- 9 - thrust ball bearing for high load capacity
- 10 - gear box
- 11 - low cover
- 12 - raised cover; may also be used as a spigot diameter
- 13 - radial bronze guide of the wormwheel, for increased stiffness and improved efficiency
- 14 - grub screw which prevents the threaded cover unscrewing
- 15 - synthetic oil lubricated worm gearbox
- 16 - radial lubricant seal
- 17 - O-Ring as lubricant seal
- 18 - breather
- 19 - oil level plug
- 20 - oil drain plug

Screw jacks MA Series

Screw jacks MA Series with 1-start acme screw TECHNICAL SPECIFICATIONS

SCREW JACK SIZE		MA 5	MA 10	MA 25	MA 50
Load capacity [kN], (push - pull)		5	10	25	50
1-start acme screw		Tr 18x4	Tr 22x5	Tr 30x6	Tr 40x7
Worm gear centre distance [mm]		30	40	50	63
Available ratio	RV	1 : 4 (4 : 16)	1 : 5 (4 : 20)	1 : 6 (4 : 24)	1 : 7 (4 : 28)
	RN	1 : 16 (2 : 32)	1 : 20	1 : 18 (2 : 36)	1 : 14 (2 : 28)
	RL	1 : 24	1 : 25	1 : 24	1 : 28
Stroke [mm] for 1 input shaft revolution	Ratio				
	RV1	1	1	1	1
	RN1	0.25	0.25	0.33	0.5
Starting efficiency	Ratio				
	RV1	0.21	0.22	0.20	0.18
	RN1	0.16	0.15	0.16	0.15
Running efficiency at 3000 rpm ⁽¹⁾	Ratio				
	RV1	0.40	0.41	0.38	0.37
	RN1	0.31	0.30	0.30	0.32
Starting torque on input shaft at max. load [Nm]	Ratio				
	RV1	3.8	7.2	19.9	44.1
	RN1	1.2	2.6	8.3	24.8
Max. permissible operating power [kW] ⁽²⁾	Ratio				
	RV1	0.40	0.60	1.2	2.4
	RN1	0.20	0.30	0.7	1.7
Reactive torque on acme screw (nut) required at max. load [Nm]	Ratio				
	RV1	0.40	0.60	1.2	2.4
	RN1	0.20	0.30	0.7	1.7
Gear box material	Ratio				
	RV1	0.40	0.60	1.2	2.4
	RN1	0.20	0.30	0.7	1.7
Reactive torque on acme screw (nut) required at max. load [Nm]		8	20	65	165
Gear box material		casting in aluminium alloy EN 1706 - AC-ALSi10Mg T6		casting in spheroidal graphite iron EN-GJS-500-7 (UNI EN 1563)	
Mass of screw jack without acme screw [kg]		2.2	4.3	13	26
Mass for every 100 mm of acme screw [kg]		0.16	0.23	0.45	0.8

⁽¹⁾ - efficiency figures at different input speed on page 36

⁽²⁾ - THERMAL limit, referred to following working conditions

duty cycle 40 % over 10 min time period (30 % over 1 hour time period) for screw jacks with travelling screw (Mod.A)

duty cycle 30 % over 10 min time period (20 % over 1 hour time period) for screw jacks with travelling nut (Mod.B)

at 25°C environment temperature

Screw jacks MA Series

Screw jacks MA Series with 1-start acme screw TECHNICAL SPECIFICATIONS

MA 80	MA 100	MA 200	MA 350	SCREW JACK SIZE		
80	100	200	350	Load capacity [kN], (push - pull)		
Tr 55x9	Tr 60x12	Tr 70x12	Tr 100x16	1-start acme screw		
63	80	100	125	Worm gear centre distance [mm]		
1 : 7 (4 : 28)	1 : 8 (4 : 32)	1 : 8 (4 : 32)	3 : 32	RV	Available ratio	
1 : 14 (2 : 28)	1 : 24	1 : 24	1 : 16 (2 : 32)	RN		
1 : 28	1 : 32	1 : 32	1 : 32	RL		
1.28	1.5	1.5	1.5	RV1	Ratio	Stroke [mm] for 1 input shaft revolution
0.64	0.5	0.5	1	RN1		
0.32	0.38	0.38	0.5	RL1		
0.18	0.20	0.17	0.16	RH1	Ratio	Starting efficiency
0.15	0.13	0.12	0.14	RV1		
0.11	0.12	0.11	0.10	RN1		
0.39	0.41	0.38	0.39	RV1	Ratio	Running efficiency at 3000 rpm ⁽¹⁾
0.33	0.32	0.31	0.34	RN1		
0.27	0.30	0.28	0.29	RL1		
77	120	282	525	RH1	Ratio	Starting torque on input shaft at max. load [Nm]
47	62	133	400	RV1		
34	50	109	280	RN1		
2.5	3.0	4.5	8.0	RV1	Ratio	Max. permissible operating power [kW] ⁽²⁾
1.8	2.6	4.0	7.0	RN1		
1.2	2.3	3.8	6.8	RL1		
368	525	1180	2880	Reactive torque on acme screw (nut) required at max. load [Nm]		
casting in spheroidal graphite iron EN-GJS-500-7 (UNI EN 1563)				Gear box material		
26	48	75	145	Mass of screw jack without acme screw [kg]		
1.6	1.8	2.5	5.2	Mass for every 100 mm of acme screw [kg]		

⁽¹⁾ - efficiency figures at different input speed on page 36

⁽²⁾ - THERMAL limit, referred to following working conditions

duty cycle 40 % over 10 min time period (30 % over 1 hour time period) for screw jacks with travelling screw (Mod.A)

duty cycle 30 % over 10 min time period (20 % over 1 hour time period) for screw jacks with travelling nut (Mod.B)

at 25°C environment temperature

Screw jacks MA Series - 1-start acme screw

Following tables show the screw jack LINEAR SPEED v [mm/s] and relative TORQUE T_1 [Nm] and POWER P_1 [kW] on input shaft, with reference to the INPUT SPEED n_1 [rpm], the RATIO (RV, RN, RL) and the LOAD [kN] applied on the screw jack.

Intermediate values for linear speed v , torque T_1 and power P_1 at different input speed can be calculated by linear interpolation of the figures stated in the table.

The figures in the tables refer to work at 25°C environment temperature and max. duty cycle of:
 40 % over 10 min time period or 30 % over 1 hour time period, for screw jacks with travelling screw (Mod.A),
 30 % over 10 min time period or 20 % over 1 hour time period, for screw jacks with travelling nut (Mod.B)

ATTENTION! The figures in the **red shaded area** indicate operational restrictions due to thermal limits. When the selection is made within such area, the duty cycle must be reduced or the greater size screw jack must be selected, in order to allow effective heat dissipation. For a better evaluation, please contact SERVOMECH Engineering Dpt.

MA 5				LOAD																							
				5 kN						4 kN						3 kN						1 kN					
				LINEAR SPEED			RATIO						RATIO						RATIO						RATIO		
n_1 [rpm]	v [mm/s]			RV1		RN1		RL1		RV1		RN1		RL1		RV1		RN1		RL1		RV1		RN1		RL1	
	RV1	RN1	RL1	T_1 Nm	P_1 kW	T_1 Nm	P_1 kW	T_1 Nm	P_1 kW	T_1 Nm	P_1 kW	T_1 Nm	P_1 kW	T_1 Nm	P_1 kW	T_1 Nm	P_1 kW	T_1 Nm	P_1 kW	T_1 Nm	P_1 kW	T_1 Nm	P_1 kW	T_1 Nm	P_1 kW		
3 000	50	12.5	8.3	2.0	0.63	0.7	0.20	0.5	0.15	1.6	0.50	0.5	0.16	0.4	0.12	1.2	0.38	0.4	0.12	0.3	0.09	0.4	0.13	0.1	0.04	0.1	0.03
1 500	25	6.3	4.2	2.2	0.35	0.7	0.11	0.5	0.08	1.8	0.28	0.6	0.09	0.4	0.07	1.3	0.21	0.4	0.07	0.3	0.05	0.4	0.07	0.1	0.02	0.1	0.02
1 000	16.7	4.2	2.8	2.3	0.24	0.7	0.08	0.6	0.06	1.9	0.20	0.6	0.06	0.4	0.05	1.4	0.15	0.4	0.05	0.3	0.03	0.5	0.05	0.1	0.01	0.1	0.01
750	12.5	3.1	2.1	2.4	0.19	0.7	0.05	0.6	0.05	1.9	0.15	0.6	0.05	0.5	0.04	1.4	0.11	0.4	0.04	0.3	0.03	0.5	0.04	0.1	0.01	0.1	0.01
500	8.3	2.1	1.4	2.5	0.13	0.8	0.04	0.6	0.03	2.0	0.11	0.6	0.03	0.5	0.03	1.5	0.08	0.5	0.02	0.4	0.02	0.5	0.03	0.1	0.01	0.1	0.01
300	5	1.3	0.8	2.6	0.08	0.8	0.03	0.7	0.02	2.1	0.07	0.7	0.02	0.5	0.02	1.6	0.05	0.5	0.02	0.4	0.01	0.5	0.02	0.2	0.01	0.1	0.01
100	1.7	0.4	0.3	2.8	0.03	0.9	0.01	0.8	0.01	2.2	0.02	0.7	0.01	0.6	0.01	1.7	0.02	0.5	0.01	0.5	0.01	0.6	0.01	0.2	0.01	0.1	0.01

MA 10				LOAD																							
				10 kN						8 kN						6 kN						2 kN					
				LINEAR SPEED			RATIO						RATIO						RATIO						RATIO		
n_1 [rpm]	v [mm/s]			RV1		RN1		RL1		RV1		RN1		RL1		RV1		RN1		RL1		RV1		RN1		RL1	
	RV1	RN1	RL1	T_1 Nm	P_1 kW	T_1 Nm	P_1 kW	T_1 Nm	P_1 kW	T_1 Nm	P_1 kW	T_1 Nm	P_1 kW	T_1 Nm	P_1 kW	T_1 Nm	P_1 kW	T_1 Nm	P_1 kW	T_1 Nm	P_1 kW	T_1 Nm	P_1 kW	T_1 Nm	P_1 kW		
3 000	50	12.5	10	3.9	1.22	1.3	0.42	1.1	0.36	3.1	0.89	1.1	0.33	0.9	0.29	2.3	0.73	0.8	0.25	0.7	0.21	0.8	0.24	0.3	0.08	0.2	0.07
1 500	25	6.3	5	4.4	0.68	1.4	0.23	1.2	0.19	3.5	0.55	1.1	0.18	0.9	0.15	2.6	0.41	0.9	0.13	0.7	0.11	0.9	0.14	0.3	0.04	0.2	0.04
1 000	16.7	4.2	3.3	4.6	0.48	1.5	0.16	1.2	0.13	3.6	0.38	1.2	0.13	1.0	0.10	2.7	0.29	0.9	0.09	0.7	0.08	0.9	0.10	0.3	0.03	0.2	0.03
750	12.5	3.1	2.5	4.7	0.37	1.6	0.12	1.3	0.10	3.8	0.30	1.2	0.10	1.0	0.08	2.8	0.22	0.9	0.07	0.8	0.06	0.9	0.07	0.3	0.02	0.2	0.02
500	8.3	2.1	1.7	5.0	0.26	1.6	0.09	1.4	0.07	4.0	0.21	1.3	0.07	1.1	0.06	3.0	0.16	1.0	0.05	0.8	0.04	1.0	0.05	0.3	0.02	0.3	0.01
300	5	1.3	1	5.1	0.16	1.8	0.05	1.5	0.05	4.1	0.13	1.4	0.04	1.2	0.04	3.1	0.10	1.1	0.03	0.9	0.03	1.0	0.03	0.3	0.01	0.3	0.01
100	1.7	0.4	0.3	5.5	0.06	2.0	0.02	1.6	0.02	4.4	0.05	1.6	0.02	1.3	0.01	3.3	0.03	1.2	0.01	1.0	0.01	1.1	0.01	0.4	0.01	0.3	0.01

MA 25				LOAD																							
				25 kN						20 kN						15 kN						10 kN					
				LINEAR SPEED			RATIO						RATIO						RATIO						RATIO		
n_1 [rpm]	v [mm/s]			RV1		RN1		RL1		RV1		RN1		RL1		RV1		RN1		RL1		RV1		RN1		RL1	
	RV1	RN1	RL1	T_1 Nm	P_1 kW	T_1 Nm	P_1 kW	T_1 Nm	P_1 kW	T_1 Nm	P_1 kW	T_1 Nm	P_1 kW	T_1 Nm	P_1 kW	T_1 Nm	P_1 kW	T_1 Nm	P_1 kW	T_1 Nm	P_1 kW	T_1 Nm	P_1 kW	T_1 Nm	P_1 kW		
3 000	50	16.7	12.5	11.7	1.83	3.5	1.11	3.6	1.12	8.4	2.63	3.5	1.11	2.8	0.89	6.3	1.97	2.7	0.83	2.1	0.67	4.6	0.74	1.9	0.30	1.6	0.25
1 500	25	8.3	6.3	12.2	1.28	4.8	0.76	3.9	0.61	9.3	1.47	3.9	0.60	3.1	0.49	7.0	1.10	2.9	0.45	2.3	0.37	4.8	0.52	2.0	0.21	1.6	0.18
1 000	16.7	5.6	4.2	12.2	1.28	5.0	0.53	4.1	0.43	9.8	1.03	4.0	0.42	3.3	0.34	7.3	0.77	3.0	0.32	2.5	0.26	5.0	0.40	2.1	0.16	1.7	0.14
750	12.5	4.2	3.1	12.7	1.00	5.2	0.41	4.2	0.33	10.2	0.80	4.2	0.33	3.4	0.27	7.6	0.60	3.1	0.24	2.5	0.20	5.4	0.28	2.2	0.12	1.8	0.10
500	8.3	2.8	2.1	13.5	0.71	5.5	0.29	4.5	0.24	10.8	0.56	4.4	0.23	3.6	0.19	8.1	0.42	3.3	0.17	2.7	0.14	5.6	0.09	2.4	0.08	2.0	0.06
300	5	1.7	1.3	14.1	0.44	5.8	0.18	4.8	0.15	11.3	0.35	4.6	0.15	3.9	0.12	8.5	0.27	3.5	0.11	2.9	0.09	6.0	0.06	2.6	0.03	2.2	0.03
100	1.7	0.6	0.4	15.1	0.16	6.5	0.07	5.5	0.06	12.1	0.13	5.2	0.05	4.4	0.05	9.0	0.09	3.9	0.04	3.3	0.03	3.2	0.04	2.8	0.02	2.4	0.01

MA 50				LOAD																							
				50 kN						35 kN						25 kN						10 kN					
				LINEAR SPEED			RATIO						RATIO						RATIO						RATIO		
n_1 [rpm]	v [mm/s]			RV1		RN1		RL1		RV1		RN1		RL1		RV1		RN1		RL1		RV1		RN1		RL1	
	RV1	RN1	RL1	T_1 Nm	P_1 kW	T_1 Nm	P_1 kW	T_1 Nm	P_1 kW	T_1 Nm	P_1 kW	T_1 Nm	P_1 kW	T_1 Nm	P_1 kW	T_1 Nm	P_1 kW	T_1 Nm	P_1 kW	T_1 Nm	P_1 kW	T_1 Nm	P_1 kW	T_1 Nm	P_1 kW		
3 000	50	25	12.5	25.0	3.92	12.4	3.91	7.7	2.40	15.1	4.73	8.7	2.73	5.4	1.68	10.8	3.38	6.2	1.95	3.8	1.20	4.3	1.35	2.5	0.78	1.5	0.48
1 500	25	12.5	6.3	25.0	3.92	14.4	2.26	8.5	1.34	17.5	2.74	10.0	1.58	6.0	0.94	12.5	1.96	7.2	1.13	4.3	0.67	5.0	0.78	2.9	0.45	1.7	0.27
1 000	16.7	8.3	4.2	26.5	2.78	13.3	1.60	9.1	0.96	18.6	1.94	10.7	1.12	6.4	0.67	13.3	1.39	7.6	0.80	4.6	0.48	5.3	0.56	3.1	0.32	1.8	0.19
750	12.5	6.3	3.1	27.4	2.15	16.0	1.25	9.5	0.74	19.2	1.51	11.1	0.87	6.6	0.52	13.7	1.08	7.9	0.62	4.7	0.37	5.5	0.43	3.2	0.25	1.9	0.15
500	8.3	4.2	2.1	28.8	1.51	16.4	0.86	10.0	0.52	20.2	1.06	11.5	0.60	7.0	0.37	14.4	0.75	8.2	0.43	5.0	0.26	5.8	0.30	3.3	0.17	2.0	0.11
300	5	2.5	1.3	30.5	0.96	17.4	0.55	10.8	0.34	21.3	0.67	12.2	0.38	7.6	0.24	15.2	0.48	8.7	0.27	5.4	0.17	6.1	0.19	3.5	0.11	2.1	0.07
100	1.7	0.8	0.4	33.0	0.35	19.3	0.20	12.5	0.13	23.1	0.24	13.5	0.14	8.8	0.09	16.5	0.17	9.7	0.10	6.3	0.07	6.6	0.07	3.9	0.04	2.5	0.03

Screw jacks MA Series - 1-start acme screw

Following tables show the screw jack LINEAR SPEED v [mm/s] and relative TORQUE T_1 [Nm] and POWER P_1 [kW] on input shaft, with reference to the INPUT SPEED n_1 [rpm], the RATIO (RV, RN, RL) and the LOAD [kN] applied on the screw jack. Intermediate values for linear speed v , torque T_1 and power P_1 at different input speed can be calculated by linear interpolation of the figures stated in the table.

The figures in the tables refer to work at 25°C environment temperature and max. duty cycle of: 40 % over 10 min time period or 30 % over 1 hour time period, for screw jacks with travelling screw (Mod.A), 30 % over 10 min time period or 20 % over 1 hour time period, for screw jacks with travelling nut (Mod.B)

ATTENTION! The figures in the **red shaded area** indicate operational restrictions due to thermal limits. When the selection is made within such area, the duty cycle must be reduced or the greater size screw jack must be selected, in order to allow effective heat dissipation. For a better evaluation, please contact SERVOMECH Engineering Dpt.

MA 80				LOAD																									
n ₁ [rpm]	LINEAR SPEED v [mm/s]			80 kN						60 kN						40 kN						20 kN							
	RATIO			RATIO						RATIO						RATIO													
	RV1	RN1	RL1	RV1	RN1	RL1	RV1	RN1	RL1	RV1	RN1	RL1	RV1	RN1	RL1	RV1	RN1	RL1	RV1	RN1	RL1								
3 000	64.3	32.1	16.1															12.7	4.00	7.6	2.39	10.6	3.33	6.4	2.00	3.8	1.20		
1 500	32.0	16.0	8.0							18.0	2.83	36.7	5.76	21.5	3.37	13.5	2.12	24.5	3.84	14.3	2.25	9.0	1.41	12.2	1.92	7.2	1.12	4.5	0.71
1 000	21.4	10.7	5.3	52.6	5.51	31.3	3.28	20.0	2.09	39.5	4.13	23.5	2.46	15.0	1.57	26.3	2.76	15.7	1.64	10.0	1.05	13.2	1.38	7.8	0.82	5.0	0.52		
750	16.1	8.0	4.0	54.7	4.30	33.8	2.65	21.0	1.65	41.0	3.22	25.3	1.99	15.8	1.24	27.4	2.15	16.9	1.32	10.5	0.82	13.7	1.07	8.4	0.66	5.3	0.41		
500	10.7	5.3	2.7	58.6	3.07	35.8	1.87	22.0	1.15	44.0	2.30	26.9	1.41	16.5	0.86	29.3	1.53	17.9	0.94	11.0	0.58	14.7	0.77	9.0	0.47	5.5	0.29		
300	6.4	3.2	1.6	65.9	2.07	38.1	1.20	24.5	0.77	49.4	1.55	28.6	0.90	18.4	0.58	33.0	1.03	19.1	0.60	12.3	0.38	16.5	0.52	9.5	0.30	6.1	0.19		
100	2.1	1.1	0.5	73.2	0.77	44.4	0.47	28.5	0.30	54.9	0.57	33.3	0.35	21.4	0.2	36.6	0.38	22.2	0.23	14.3	0.15	18.3	0.19	11.1	0.12	7.1	0.07		

MA 100				LOAD																							
n ₁ [rpm]	LINEAR SPEED v [mm/s]			100 kN						80 kN						50 kN						20 kN					
	RATIO			RATIO						RATIO						RATIO											
	RV1	RN1	RL1	RV1	RN1	RL1	RV1	RN1	RL1	RV1	RN1	RL1	RV1	RN1	RL1	RV1	RN1	RL1	RV1	RN1	RL1						
3 000	75	25	18.8											15.9	5.00			12.4	3.91	10.0	3.12	11.6	3.66	5.0	1.56	4.0	1.25
1 500	37.5	12.5	9.4			28.2	4.43	22.5	3.54			22.6	3.55	18.0	2.83	33.2	5.22	14.1	2.22	11.3	1.77	13.3	2.09	5.6	0.89	4.5	0.71
1 000	25	8.3	6.3	70.8	7.42	30.0	3.14	24.1	2.52	56.7	5.93	24.0	2.52	19.2	2.02	35.4	3.71	15.0	1.57	12.0	1.26	14.2	1.48	6.0	0.63	4.8	0.50
750	18.8	6.3	4.7	73.5	5.77	31.3	2.46	25.3	1.99	58.8	4.61	25.1	1.97	20.2	1.59	36.7	2.88	15.7	1.23	12.6	0.99	14.7	1.15	6.3	0.49	5.0	0.40
500	12.5	4.2	3.1	77.0	4.03	32.9	1.72	26.6	1.39	61.6	3.23	26.3	1.38	21.3	1.12	38.5	2.02	16.4	0.86	13.5	0.70	15.4	0.81	6.6	0.34	5.3	0.28
300	7.5	2.5	1.9	82.3	2.59	35.2	1.11	28.7	0.90	65.9	2.07	28.2	0.88	22.9	0.72	41.2	1.29	17.6	0.55	14.3	0.45	16.5	0.52	7.0	0.22	5.7	0.18
100	2.5	0.8	0.6	89.1	0.93	40.0	0.42	33.0	0.34	71.3	0.75	32.0	0.33	26.4	0.28	44.5	0.47	20.0	0.21	16.5	0.17	17.8	0.19	8.0	0.08	6.6	0.07

MA 200				LOAD																							
n ₁ [rpm]	LINEAR SPEED v [mm/s]			200 kN						150 kN						100 kN						50 kN					
	RATIO			RATIO						RATIO						RATIO											
	RV1	RN1	RL1	RV1	RN1	RL1	RV1	RN1	RL1	RV1	RN1	RL1	RV1	RN1	RL1	RV1	RN1	RL1	RV1	RN1	RL1						
3 000	75	25	18.8															25.7	8.06	21.3	6.70			12.8	4.03	10.7	3.35
1 500	37.5	12.5	9.4					48.9	7.68			45.4	7.13	36.7	5.76			30.3	4.75	24.5	3.84	36.1	5.66	15.1	2.38	12.2	1.92
1 000	25	8.3	6.3			65.0	6.80	52.1	5.48			48.7	5.10	39.1	4.09	76.5	8.01	32.5	3.40	26.1	2.73	38.8	4.01	16.2	1.70	13.0	1.36
750	18.8	6.3	4.7			68.6	5.39	52.8	4.30	119	9.37	51.4	4.04	41.1	3.22	79.6	6.25	34.3	2.69	27.4	2.15	39.8	3.12	17.1	1.35	13.7	1.07
500	12.5	4.2	3.1	167	8.77	71.4	3.74	57.7	3.02	125	6.58	53.5	2.80	43.2	2.26	83.8	4.39	35.7	1.87	28.8	1.51	41.9	2.19	17.8	0.93	14.4	0.75
300	7.5	2.5	1.9	178	5.62	76.1	2.39	61.8	1.94	134	4.21	57.1	1.79	46.4	1.46	89.4	2.81	38.1	1.20	30.9	0.97	44.7	1.40	19.0	0.60	15.5	0.49
100	2.5	0.8	0.6	195	2.05	87.3	0.92	71.3	0.76	146	1.54	65.9	0.69	54.3	0.57	97.8	1.02	44.0	0.46	36.2	0.38	48.9	0.51	22.0	0.23	18.1	0.19

MA 350				LOAD																								
n ₁ [rpm]	LINEAR SPEED v [mm/s]			350 kN						250 kN						150 kN						100 kN						
	RATIO			RATIO						RATIO						RATIO												
	RV1	RN1	RL1	RV1	RN1	RL1	RV1	RN1	RL1	RV1	RN1	RL1	RV1	RN1	RL1	RV1	RN1	RL1	RV1	RN1	RL1							
3 000	75	50	25																									
1 500	37.5	25	12.5																									
1 000	25	16.7	8.3					120	12.6			144	15.1	86.1	9.02	120	12.6	86.5	9.00	51.7	5.41	80.4	8.42	57.7	6.04	34.4	3.61	
750	18.8	12.5	6.3			210	16.5	127	9.99	209	16.4	150	11.7	90.8	7.13	125	9.87	90.1	7.07	54.5	4.28	83.8	6.58	60.1	4.72	36.3	2.85	
500	12.5	8.3	4.2	308	16.1	223	11.7	134	7.04	220	11.5	159	8.37	96.1	5.03	132	6.92	95.9	5.02	57.7	3.02	88.1	4.61	63.9	3.35	38.4	2.01	
300	7.5	5	2.5	331	10.4	242	7.61	144	4.53	236	7.44	173	5.43	103	3.24	142	4.46	103	3.26	61.8	1.94	94.7	2.98	69.2	2.17	41.2	1.29	
100	2.5	1.7	0.8	369	3.87	269	2.82	166	1.75	264	2.76	192	2.01	119	1.25	158	1.66	115	1.21	71.5	0.75	105	1.11	76.9	0.80	47.6	0.50	

Screw jacks MA Series

Screw jacks MA Series with 2-starts acme screw TECHNICAL SPECIFICATIONS

SCREW JACK SIZE		MA 5	MA 10	MA 25	MA 50
Load capacity [kN], (push - pull)		5	10	25	50
2-starts acme screw		Tr 18x8 (P4)	Tr 22x10 (P5)	Tr 30x12 (P6)	Tr 40x14 (P7)
Worm gear centre distance [mm]		30	40	50	63
Available ratio	RV	1 : 4 (4 : 16)	1 : 5 (4 : 20)	1 : 6 (4 : 24)	1 : 7 (4 : 28)
	RN	1 : 16 (2 : 32)	1 : 20	1 : 18 (2 : 36)	1 : 14 (2 : 28)
	RL	1 : 24	1 : 25	1 : 24	1 : 28
Stroke [mm] for 1 input shaft revolution	Ratio				
	RV1	2	2	2	2
	RN1	0.50	0.50	0.67	1
Starting efficiency	Ratio				
	RV1	0.32	0.33	0.31	0.29
	RN1	0.25	0.22	0.23	0.24
Running efficiency at 3000 rpm ⁽¹⁾	Ratio				
	RV1	0.52	0.53	0.51	0.50
	RN1	0.41	0.40	0.43	0.44
Starting torque on input shaft at max. load [Nm]	Ratio				
	RV1	4.9	9.7	26	56
	RN1	1.6	3.6	12	34
Max. permissible operating power [kW] ⁽²⁾	Ratio				
	RV1	0.52	0.78	1.2	2.4
	RN1	0.26	0.40	0.7	1.7
Reactive torque on acme screw (nut) required at max. load [Nm]	Ratio				
	RV1	12	30	97	243
	RN1				
Gear box material		casting in aluminium alloy EN 1706 - AC-ALSi10Mg T6		casting in spheroidal graphite iron EN-GJS-500-7 (UNI EN 1563)	
Mass of screw jack without acme screw [kg]		2.2	4.3	13	26
Mass for every 100 mm of acme screw [kg]		0.16	0.23	0.45	0.8

⁽¹⁾ - efficiency figures at different input speed on page 36

⁽²⁾ - THERMAL limit, referred to following working conditions

duty cycle 40 % over 10 min time period (30 % over 1 hour time period) for screw jacks with travelling screw (Mod.A)

duty cycle 30 % over 10 min time period (20 % over 1 hour time period) for screw jacks with travelling nut (Mod.B)

at 25°C environment temperature

Screw jacks MA Series

Screw jacks MA Series with 2-starts acme screw TECHNICAL SPECIFICATIONS

MA 80	MA 100	MA 200	MA 350	SCREW JACK SIZE		
80	100	200	350	Load capacity [kN], (push - pull)		
Tr 55x18 (P9)	Tr 60x24 (P12)	Tr 70x24 (P12)	Tr 100x32 (P16)	2-starts acme screw		
63	80	100	125	Worm gear centre distance [mm]		
1 : 7 (4 : 28)	1 : 8 (4 : 32)	1 : 8 (4 : 32)	3 : 32	RV	Available ratio	
1 : 14 (2 : 28)	1 : 24	1 : 24	1 : 16 (2 : 32)	RN		
1 : 28	1 : 32	1 : 32	1 : 32	RL		
2.57	3	3	3	RV1	Ratio	Stroke [mm] for 1 input shaft revolution
1.29	1	1	2	RN1		
0.64	0.75	0.75	1	RL1		
0.28	0.30	0.28	0.26	RH1	Ratio	Starting efficiency
0.23	0.21	0.20	0.23	RV1		
0.17	0.19	0.18	0.18	RN1		
0.51	0.54	0.52	0.51	RV1	Ratio	Running efficiency at 3000 rpm ⁽¹⁾
0.44	0.43	0.42	0.48	RN1		
0.38	0.41	0.39	0.41	RL1		
119	158	342	650	RH1	Ratio	Starting torque on input shaft at max. load [Nm]
72	76	163	480	RV1		
48	63	134	316	RN1		
3.2	4	6.2	10.5	RV1	Ratio	Max. permissible operating power [kW] ⁽²⁾
2.4	3.5	5.4	10	RN1		
1.7	3.1	5.3	9.6	RL1		
520	775	1 690	4 100	Reactive torque on acme screw (nut) required at max. load [Nm]		
casting in spheroidal graphite iron EN-GJS-500-7 (UNI EN 1563)				Gear box material		
26	48	75	145	Mass of screw jack without acme screw [kg]		
1.6	1.8	2.5	5.2	Mass for every 100 mm of acme screw [kg]		

⁽¹⁾ - efficiency figures at different input speed on page 36

⁽²⁾ - THERMAL limit, referred to following working conditions

duty cycle 40 % over 10 min time period (30 % over 1 hour time period) for screw jacks with travelling screw (Mod.A)

duty cycle 30 % over 10 min time period (20 % over 1 hour time period) for screw jacks with travelling nut (Mod.B)

at 25°C environment temperature

Screw jacks MA Series - 2-starts acme screw

Following tables show the screw jack LINEAR SPEED v [mm/s] and relative TORQUE T_1 [Nm] and POWER P_1 [kW] on input shaft, with reference to the INPUT SPEED n_1 [rpm], the RATIO (RV, RN, RL) and the LOAD [kN] applied on the screw jack.

Intermediate values for linear speed v , torque T_1 and power P_1 at different input speed can be calculated by linear interpolation of the figures stated in the table.

The figures in the tables refer to work at 25°C environment temperature and max. duty cycle of:
 40 % over 10 min time period or 30 % over 1 hour time period, for screw jacks with travelling screw (Mod.A),
 30 % over 10 min time period or 20 % over 1 hour time period, for screw jacks with travelling nut (Mod.B)

ATTENTION! The figures in the **red shaded area** indicate operational restrictions due to thermal limits. When the selection is made within such area, the duty cycle must be reduced or the greater size screw jack must be selected, in order to allow effective heat dissipation. For a better evaluation, please contact SERVOMECH Engineering Dpt.

MA 5					LOAD																							
					5 kN						4 kN						3 kN						1 kN					
n_1 [rpm]	LINEAR SPEED v [mm/s]				RATIO						RATIO						RATIO						RATIO					
					RV2		RN2		RL2		RV2		RN2		RL2		RV2		RN2		RL2		RV2		RN2		RL2	
	RV2	RN2	RL2		T_1 Nm	P_1 kW	T_1 Nm	P_1 kW	T_1 Nm	P_1 kW	T_1 Nm	P_1 kW	T_1 Nm	P_1 kW	T_1 Nm	P_1 kW	T_1 Nm	P_1 kW	T_1 Nm	P_1 kW	T_1 Nm	P_1 kW	T_1 Nm	P_1 kW	T_1 Nm	P_1 kW	T_1 Nm	P_1 kW
3 000	100	25	16.7	3.1	0.96	1.0	0.30	0.8	0.23	2.5	0.77	0.8	0.24	0.6	0.19	1.9	0.58	0.6	0.18	0.5	0.14	0.6	0.19	0.2	0.06	0.2	0.05	
1 500	50	12.5	8.3	3.3	0.52	1.1	0.17	0.8	0.13	2.7	0.42	0.9	0.13	0.7	0.10	2.0	0.31	0.7	0.10	0.5	0.08	0.7	0.10	0.2	0.03	0.2	0.03	
1 000	33.3	8.3	5.6	3.5	0.36	1.1	0.12	0.9	0.09	2.8	0.29	0.9	0.09	0.7	0.07	2.1	0.22	0.7	0.07	0.5	0.05	0.7	0.07	0.2	0.02	0.2	0.02	
750	25	6.3	4.2	3.6	0.28	1.2	0.09	0.9	0.07	2.9	0.23	0.9	0.07	0.8	0.06	2.2	0.17	0.7	0.05	0.6	0.04	0.7	0.06	0.3	0.02	0.2	0.01	
500	16.7	4.2	2.8	3.8	0.20	1.2	0.06	1.0	0.05	3.1	0.16	1.0	0.05	0.8	0.04	2.3	0.12	0.7	0.04	0.6	0.03	0.8	0.04	0.3	0.01	0.2	0.01	
300	10	2.5	1.7	4.0	0.12	1.3	0.04	1.0	0.03	3.2	0.10	1.0	0.03	0.8	0.03	2.4	0.07	0.8	0.02	0.6	0.02	0.8	0.02	0.3	0.01	0.2	0.01	
100	3.3	0.8	0.6	4.4	0.05	1.4	0.01	1.2	0.01	3.5	0.04	1.2	0.01	1.0	0.01	2.6	0.03	0.9	0.01	0.7	0.01	0.9	0.01	0.3	0.01	0.3	0.01	

MA 10					LOAD																							
					10 kN						8 kN						6 kN						2 kN					
n_1 [rpm]	LINEAR SPEED v [mm/s]				RATIO						RATIO						RATIO						RATIO					
					RV2		RN2		RL2		RV2		RN2		RL2		RV2		RN2		RL2		RV2		RN2		RL2	
	RV2	RN2	RL2		T_1 Nm	P_1 kW	T_1 Nm	P_1 kW	T_1 Nm	P_1 kW	T_1 Nm	P_1 kW	T_1 Nm	P_1 kW	T_1 Nm	P_1 kW	T_1 Nm	P_1 kW	T_1 Nm	P_1 kW	T_1 Nm	P_1 kW	T_1 Nm	P_1 kW	T_1 Nm	P_1 kW	T_1 Nm	P_1 kW
3 000	100	25	20	6.1	1.90	2.0	0.62	1.7	0.52	4.9	1.52	1.6	0.49	1.3	0.41	3.7	1.14	1.2	0.37	1.0	0.31	1.2	0.38	0.4	0.12	0.4	0.10	
1 500	50	12.5	10	6.6	1.03	2.2	0.34	1.9	0.29	5.3	0.82	1.8	0.27	1.5	0.23	4.0	0.62	1.3	0.21	1.1	0.17	1.3	0.21	0.5	0.07	0.4	0.05	
1 000	33.3	8.3	6.7	6.9	0.72	2.3	0.24	1.9	0.20	5.5	0.57	1.9	0.19	1.6	0.16	4.1	0.43	1.4	0.14	1.2	0.12	1.4	0.14	0.5	0.05	0.4	0.04	
750	25	6.3	5	7.2	0.56	2.4	0.19	2.1	0.16	5.8	0.45	1.9	0.15	1.6	0.13	4.3	0.34	1.5	0.11	1.2	0.10	1.5	0.11	0.5	0.04	0.4	0.03	
500	16.7	4.2	3.3	7.5	0.39	2.6	0.13	2.2	0.11	6.0	0.31	2.1	0.11	1.7	0.09	5.5	0.24	1.6	0.08	1.3	0.07	1.5	0.08	0.5	0.03	0.5	0.02	
300	10	2.5	2	7.8	0.24	2.8	0.09	2.3	0.07	6.2	0.19	2.2	0.07	1.9	0.06	4.7	0.15	1.7	0.05	1.4	0.04	1.6	0.05	0.6	0.02	0.5	0.01	
100	3.3	0.8	0.7	8.6	0.09	3.2	0.03	2.7	0.03	6.9	0.07	2.5	0.03	2.2	0.02	5.2	0.05	1.9	0.02	1.6	0.02	1.7	0.02	0.7	0.01	0.6	0.01	

MA 25					LOAD																							
					25 kN						20 kN						15 kN						10 kN					
n_1 [rpm]	LINEAR SPEED v [mm/s]				RATIO						RATIO						RATIO						RATIO					
					RV2		RN2		RL2		RV2		RN2		RL2		RV2		RN2		RL2		RV2		RN2		RL2	
	RV2	RN2	RL2		T_1 Nm	P_1 kW	T_1 Nm	P_1 kW	T_1 Nm	P_1 kW	T_1 Nm	P_1 kW	T_1 Nm	P_1 kW	T_1 Nm	P_1 kW	T_1 Nm	P_1 kW	T_1 Nm	P_1 kW	T_1 Nm	P_1 kW	T_1 Nm	P_1 kW	T_1 Nm	P_1 kW	T_1 Nm	P_1 kW
3 000	100	33.3	25	17.0	2.66	7.0	1.10	5.8	0.91	13.6	2.13	5.0	1.56	4.1	1.29	9.4	2.94	3.8	1.17	3.1	0.97	6.3	1.96	2.5	0.78	2.1	0.65	
1 500	50	16.7	12.5	17.7	1.85	7.4	0.78	6.1	0.64	14.2	1.48	6.0	0.62	4.9	0.51	10.6	1.11	4.5	0.47	3.7	0.38	7.1	0.74	3.0	0.31	2.5	0.25	
1 000	33.3	11.1	8.3	18.2	1.43	7.7	0.60	6.3	0.49	14.6	1.14	6.1	0.48	5.1	0.39	10.9	0.86	4.6	0.36	3.8	0.30	7.3	0.57	3.1	0.24	2.5	0.20	
750	25	8.3	6.3	19.5	1.02	8.1	0.42	6.8	0.35	15.6	0.82	6.5	0.34	5.4	0.28	11.7	0.61	4.9	0.25	4.1	0.21	7.8	0.41	3.2	0.17	2.7	0.14	
500	16.7	5.6	4.2	20.5	0.64	8.6	0.27	7.3	0.23	16.4	0.52	6.9	0.22	5.8	0.18	12.3	0.39	5.2	0.16	4.4	0.14	8.2	0.26	3.4	0.11	2.9	0.09	
300	10	3.3	2.5	22.6	0.24	9.8	0.10	8.5	0.09	18.6	0.19	7.8	0.08	6.8	0.07	13.5	0.14	5.9	0.06	5.1	0.05	9.1	0.09	3.9	0.04	3.4	0.04	

MA 50					LOAD																							
					50 kN						35 kN						25 kN						10 kN					
n_1 [rpm]	LINEAR SPEED v [mm/s]				RATIO						RATIO						RATIO						RATIO					
					RV2		RN2		RL2		RV2		RN2		RL2		RV2		RN2		RL2		RV2		RN2		RL2	
	RV2	RN2	RL2		T_1 Nm	P_1 kW	T_1 Nm	P_1 kW	T_1 Nm	P_1 kW	T_1 Nm	P_1 kW	T_1 Nm	P_1 kW	T_1 Nm	P_1 kW	T_1 Nm	P_1 kW	T_1 Nm	P_1 kW	T_1 Nm	P_1 kW	T_1 Nm	P_1 kW	T_1 Nm	P_1 kW	T_1 Nm	P_1 kW
3 000	100	50	25									12.6	3.95	7.4	2.33	16.0	5.00	9.0	2.82	5.3	1.7	6.4	2.00	3.6	1.13	2.1	0.67	
1 500	50	25	12.5	34.8	5.46	20.1	3.15	12.1	1.91	24.3	3.82	14.1	2.21	8.5	1.33	17.4	2.73	10.0	1.58	6.1	0.95	7.0	1.09	4.0	0.63	2.5	0.38	
1 000	33.3	16.7	8.3	37.1	3.88	21.3	2.23	13.1	1.37	26.0	2.72	14.9	1.56	9.2	0.96	18.5	1.94	10.6	1.11	6.6	0.69	7.4	0.78	4.3	0.45	2.6	0.27	
750	25	12.5	6.3	38.2	3.00	22.6	1.77	13.5	1.06	26.7	2.10	15.8	1.24	9.5	0.74	19.1	1.50	11.3	0.89	6.7	0.53	7.7	0.60	4.5	0.35	2.7	0.21	
500	16.7	8.3	4.2	40.6	2.13	23.5	1.23	14.4	0.75	28.4	1.49	16.4	0.86	10.1	0.53	20.3	1.06	11.7	0.61	7.2	0.38	8.1	0.43	4.7	0.25	2.9	0.15	
300	10	5	2.5	43.3	1.36	24.8	0.78	15.8	0.49	30.3	0.95	17.3	0.54	11.0	0.35	21.6	0.68	12.4	0.39	7.9	0.25	8.7	0.27	5.0	0.16	3.2	0.10	
100	3.3	1.7	0.8	46.7	0.49	28.0	0.29	18.2	0.19	32.7	0.34	19.6	0.20	12.7	0.13	23.3	0.24	14.0	0.15	9.1	0.10	9.4	0.10	5.6	0.06	3.7	0.04	

Screw jacks MA Series - 2-starts acme screw

Following tables show the screw jack LINEAR SPEED v [mm/s] and relative TORQUE T_1 [Nm] and POWER P_1 [kW] on input shaft, with reference to the INPUT SPEED n_1 [rpm], the RATIO (RV, RN, RL) and the LOAD [kN] applied on the screw jack.

Intermediate values for linear speed v , torque T_1 and power P_1 at different input speed can be calculated by linear interpolation of the figures stated in the table.

The figures in the tables refer to work at 25°C environment temperature and max. duty cycle of:

40 % over 10 min time period or 30 % over 1 hour time period, for screw jacks with travelling screw (Mod.A),

30 % over 10 min time period or 20 % over 1 hour time period, for screw jacks with travelling nut (Mod.B)

ATTENTION! The figures in the **red shaded area** indicate operational restrictions due to thermal limits. When the selection is made within such area, the duty cycle must be reduced or the greater size screw jack must be selected, in order to allow effective heat dissipation. For a better evaluation, please contact SERVOMECH Engineering Dpt.

MA 80				LOAD																							
				80 kN				60 kN				40 kN				20 kN											
				RV2		RN2		RL2		RV2		RN2		RL2		RV2		RN2		RL2		RV2		RN2		RL2	
n_1 [rpm]	LINEAR SPEED v [mm/s]			T_1 Nm	P_1 kW	T_1 Nm	P_1 kW	T_1 Nm	P_1 kW	T_1 Nm	P_1 kW	T_1 Nm	P_1 kW	T_1 Nm	P_1 kW	T_1 Nm	P_1 kW	T_1 Nm	P_1 kW	T_1 Nm	P_1 kW	T_1 Nm	P_1 kW				
	3 000	129	64.3	32.1													18.6	5.84	10.9	3.42	16.2	5.07	9.3	2.92	5.5	1.71	
1 500	64.3	32.1	16.1					25.0	3.92			30.6	4.81	18.8	2.94	35.8	5.62	20.4	3.20	12.5	1.96	17.9	2.81	10.2	1.60	6.3	0.98
1 000	42.9	21.4	10.7	76.2	7.98	43.9	4.59	27.4	2.87	57.2	5.98	32.9	3.46	20.6	2.15	38.1	3.99	22.0	2.30	13.7	1.43	19.1	1.99	11.0	1.15	6.9	0.72
750	32.1	16.1	8.0	78.1	6.13	46.7	3.67	28.6	2.24	58.5	4.60	35.0	2.75	21.5	1.68	39.0	3.06	23.4	1.83	14.3	1.12	19.5	1.53	11.7	0.92	7.2	0.56
500	21.4	10.7	5.4	82.3	4.31	49.1	2.57	30.0	1.57	61.8	3.23	36.8	1.93	22.5	1.18	41.2	2.15	24.6	1.28	15.0	0.78	20.6	1.08	12.3	0.68	7.5	0.39
300	12.9	6.4	3.2	90.5	2.84	51.9	1.63	33.0	1.03	67.9	2.13	38.9	1.22	24.7	0.78	45.3	1.42	25.9	0.81	16.5	0.52	22.7	0.71	13.0	0.41	8.3	0.26
100	4.3	2.1	1.1	98.9	1.03	59.3	0.62	37.9	0.40	74.1	0.78	44.5	0.47	28.4	0.30	49.4	0.52	29.7	0.31	19.0	0.20	24.7	0.26	14.8	0.16	9.5	0.10

MA 100				LOAD																							
				100 kN				80 kN				50 kN				20 kN											
				RV2		RN2		RL2		RV2		RN2		RL2		RV2		RN2		RL2		RV2		RN2		RL2	
n_1 [rpm]	LINEAR SPEED v [mm/s]			T_1 Nm	P_1 kW	T_1 Nm	P_1 kW	T_1 Nm	P_1 kW	T_1 Nm	P_1 kW	T_1 Nm	P_1 kW	T_1 Nm	P_1 kW	T_1 Nm	P_1 kW	T_1 Nm	P_1 kW	T_1 Nm	P_1 kW	T_1 Nm	P_1 kW				
	3 000	150	50	37.5									23.3	7.31			18.4	5.76	14.6	4.57	17.8	5.58	7.4	2.30	5.8	1.83	
1 500	75	25	18.8			40.8	6.40	33.2	5.20			32.6	5.12	26.5	4.16	48.6	7.63	20.4	3.20	16.6	2.60	19.4	3.05	8.2	1.28	6.7	1.04
1 000	50	16.7	12.5			44.6	4.67	36.1	3.78	82.3	8.62	35.7	3.73	28.9	3.02	51.5	5.39	22.3	2.33	18.1	1.89	20.6	2.16	8.9	0.93	7.2	0.76
750	37.5	12.5	9.4	106	8.32	46.6	3.66	36.8	2.89	84.8	6.66	37.3	2.93	29.5	2.31	53.0	4.16	23.3	1.83	18.4	1.44	21.2	1.66	9.3	0.73	7.4	0.58
500	25	8.3	6.3	112	5.87	48.3	2.53	38.9	2.04	89.7	4.69	38.6	2.02	31.2	1.63	56.0	2.93	24.1	1.26	19.5	1.02	22.4	1.17	9.7	0.51	7.8	0.41
300	15	5	3.8	121	3.80	52.2	1.64	43.4	1.36	96.9	3.04	41.7	1.31	34.8	1.09	60.5	1.90	26.1	0.82	21.7	0.68	24.2	0.76	10.5	0.33	8.7	0.27
100	5	1.7	1.3	131	1.37	59.5	0.62	50.0	0.52	105	1.10	47.6	0.50	40.0	0.42	65.4	0.69	29.8	0.31	25.0	0.26	26.2	0.27	11.9	0.12	10.0	0.10

MA 200				LOAD																							
				200 kN				150 kN				100 kN				50 kN											
				RV2		RN2		RL2		RV2		RN2		RL2		RV2		RN2		RL2		RV2		RN2		RL2	
n_1 [rpm]	LINEAR SPEED v [mm/s]			T_1 Nm	P_1 kW	T_1 Nm	P_1 kW	T_1 Nm	P_1 kW	T_1 Nm	P_1 kW	T_1 Nm	P_1 kW	T_1 Nm	P_1 kW	T_1 Nm	P_1 kW	T_1 Nm	P_1 kW	T_1 Nm	P_1 kW	T_1 Nm	P_1 kW				
	3 000	150	50	37.5													38.2	12.0	30.5	9.56	45.5	14.3	19.1	6.00	15.2	4.78	
1 500	75	25	18.8			84.2	13.3	67.8	10.7			63.2	9.92	50.9	7.99			42.1	6.61	33.9	5.32	50.3	7.89	21.1	3.31	17.0	2.66
1 000	50	16.7	12.5			90.5	9.48	74.3	7.77			67.9	7.11	55.7	5.83	107	11.2	45.3	4.74	37.1	3.89	53.5	5.61	22.6	2.37	18.6	1.94
750	37.5	12.5	9.4			96.6	7.58	78.1	6.13	166	13.0	72.4	5.69	58.6	4.60	110	8.66	48.3	3.79	39.1	3.07	55.1	4.33	24.2	1.90	19.5	1.53
500	25	8.3	6.3	235	12.3	103	5.38	81.8	4.28	177	9.23	77.1	4.04	61.4	3.21	118	6.15	51.4	2.69	40.9	2.14	58.8	3.08	25.7	1.35	20.5	1.07
300	15	5	3.8	254	7.98	110	3.45	90.1	2.83	191	5.99	82.5	2.59	67.6	2.12	127	3.99	55.0	1.73	45.0	1.41	63.5	2.00	27.5	0.86	22.5	0.71
100	5	1.7	1.3	279	2.92	127	1.33	103	1.08	210	2.19	95.1	1.00	77.3	0.81	140	1.46	63.4	0.66	51.6	0.54	69.7	0.73	31.7	0.33	25.8	0.27

MA 350				LOAD																									
				350 kN				250 kN				150 kN				100 kN													
				RV2		RN2		RL2		RV2		RN2		RL2		RV2		RN2		RL2		RV2		RN2		RL2			
n_1 [rpm]	LINEAR SPEED v [mm/s]			T_1 Nm	P_1 kW	T_1 Nm	P_1 kW	T_1 Nm	P_1 kW	T_1 Nm	P_1 kW	T_1 Nm	P_1 kW	T_1 Nm	P_1 kW	T_1 Nm	P_1 kW	T_1 Nm	P_1 kW	T_1 Nm	P_1 kW	T_1 Nm	P_1 kW						
	3 000	150	100	50													59.0	18.5					67.0	21.4	39.3	12.4			
1 500	75	50	25					154	24.2					110	17.3	155	24.3	111	17.5	66.1	10.4	103	16.2	74.0	11.6	44.1	6.92		
1 000	50	33.3	16.7					168	17.6			198	20.7	120	12.5	163	17.1	119	12.4	71.8	7.51	109	11.4	79.0	8.27	47.9	5.01		
750	37.5	25	12.5					289	22.7	180	14.1	286	22.4	207	16.2	128	10.1	171	13.5	124	9.73	76.8	6.03	114	8.96	82.6	6.49	51.2	4.02
500	25	16.7	8.3	423	22.2	315	16.5	191	9.98	302	15.8	225	11.8	136	7.13	181	9.49	135	7.06	81.7	4.28	121	6.32	89.9	4.70	54.5	2.85		
300	15	10	5	461	14.5	337	10.6	200	6.26	330	10.4	241	7.57	143	4.47	198	6.21	145	4.54	85.5	2.68	132	4.14	96.4	3.03	57.0	1.79		
100	5	3.3	1.7	496	5.19	381	4.0	242	2.53	354	3.70	272	2.85	173	1.81	212	2.22	163	1.71	104	1.08	142	1.48	109	1.14	69.0	0.72		

Screw jacks MA Series

Screw jacks MA Series with 3-starts acme screw TECHNICAL SPECIFICATIONS

SCREW JACK SIZE		MA 25	MA 50	MA 80	MA 100	MA 200	MA 350	
Load capacity [kN], (push - pull)		25	50	80	100	200	350	
3-starts acme screw		Tr 30x18 (P6)	Tr 40x21 (P7)	Tr 55x27 (P9)	Tr 60x36 (P12)	Tr 70x36 (P12)	Tr 100x48 (P16)	
Worm gear centre distance [mm]		50	63	63	80	100	125	
Available ratio	RV	1 : 6 (4 : 24)	1 : 7 (4 : 28)	1 : 7 (4 : 28)	1 : 8 (4 : 32)	1 : 8 (4 : 32)	3 : 32	
	RN	1 : 18 (2 : 36)	1 : 14 (2 : 28)	1 : 14 (2 : 28)	1 : 24	1 : 24	1 : 16 (2 : 32)	
	RL	1 : 24	1 : 28	1 : 28	1 : 32	1 : 32	1 : 32	
Stroke [mm] for 1 input shaft revolution	Ratio							
	RV3	3	3	3.86	4.5	4.5	4.5	
	RN3	1	1.5	1.93	1.5	1.5	3	
Starting efficiency	Ratio							
	RV3	0.36	0.34	0.33	0.36	0.34	0.31	
	RN3	0.28	0.29	0.28	0.27	0.24	0.28	
Running efficiency at 3000 rpm ⁽¹⁾	Ratio							
	RV3	0.57	0.56	0.57	0.59	0.58	0.57	
	RN3	0.48	0.50	0.50	0.52	0.48	0.54	
Starting torque on input shaft at max. load [Nm]	Ratio							
	RV3	33	70	148	201	427	803	
	RN3	15	42	89	88	203	594	
Max. permissible operating power [kW] ⁽²⁾	Ratio							
	RV3	1.8	3.6	3.6	4.3	6.9	11.7	
	RN3	1.1	2.6	2.6	4	6.2	11	
Reactive torque on acme screw (nut) required at max. load [Nm]	Ratio							
	RV3	123	303	642	980	2 100	5 041	
	RN3							
Gear box material		casting in spheroidal graphite iron EN-GJS-500-7 (UNI EN 1563)						
Mass of screw jack without acme screw [kg]		13	26	26	48	75	145	
Mass for every 100 mm of acme screw [kg]		0.45	0.8	1.6	1.8	2.5	5.2	

⁽¹⁾ - efficiency figures at different input speed on page 36

⁽²⁾ - THERMAL limit, referred to work with max. duty cycle 40 % over 10 min time period (30 % over 1 hour time period) at 25°C environment temperature

Screw jacks MA Series - travelling screw (Mod.A)

- 3-starts acme screw -

Following tables show the screw jack LINEAR SPEED v [mm/s] and relative TORQUE T_1 [Nm] and POWER P_1 [kW] on input shaft, with reference to the INPUT SPEED n_1 [rpm], the RATIO (RV, RN, RL) and the LOAD [kN] applied on the screw jack.

Intermediate values for linear speed v , torque T_1 and power P_1 at different input speed can be calculated by linear interpolation of the figures stated in the table.

The figures in the tables refer to work with max. duty cycle of 40 % over 10 min time period or 30 % over 1 hour time period at 25°C environment temperature.

ATTENTION! The figures in the **red shaded area** indicate operational restrictions due to thermal limits. When the selection is made within such area, the duty cycle must be reduced or the greater size screw jack must be selected, in order to allow effective heat dissipation. For a better evaluation, please contact SERVOMECH Engineering Dpt.

MA 25				LOAD																							
				25 kN				20 kN				15 kN				10 kN											
				RATIO			T ₁ Nm	P ₁ kW	RATIO			T ₁ Nm	P ₁ kW	RATIO			T ₁ Nm	P ₁ kW	RATIO			T ₁ Nm	P ₁ kW				
n ₁ [rpm]	LINEAR SPEED v [mm/s]			RV3	RN3	RL3			RV3	RN3	RL3			RV3	RN3	RL3			RV3	RN3	RL3			RV3	RN3	RL3	RV3
	RV3	RN3	RL3	T ₁	P ₁	T ₁	P ₁	T ₁	P ₁	T ₁	P ₁	T ₁	P ₁	T ₁	P ₁	T ₁	P ₁	T ₁	P ₁	T ₁	P ₁						
3 000	150	50	37.5			8.2	2.58	6.8	2.12			6.6	2.07	5.4	1.70	12.7	3.97	5.0	1.55	4.1	1.27	8.5	2.65	3.3	1.03	2.7	0.85
1 500	75	25	18.8	22.6	3.55	9.2	1.44	7.6	1.18	18.1	2.84	7.4	1.15	6.1	0.95	13.6	2.13	5.5	0.86	4.5	0.71	9.1	1.42	3.7	0.58	3.0	0.47
1 000	50	16.7	12.5	23.5	2.45	9.7	1.01	7.9	0.82	18.8	1.96	7.7	0.81	6.3	0.66	14.1	1.47	5.8	0.60	4.8	0.49	9.4	0.98	3.9	0.40	3.2	0.33
	750	37.5	9.4	24.1	1.89	9.9	0.78	8.2	0.64	19.2	1.51	8.0	0.62	6.5	0.51	14.4	1.13	6.0	0.47	4.9	0.38	9.6	0.75	4.0	0.31	3.3	0.26
	500	25	6.3	25.5	1.33	10.5	0.55	8.7	0.46	20.4	1.07	8.4	0.44	7.0	0.36	15.3	0.80	6.3	0.33	5.3	0.27	10.2	0.53	4.2	0.22	3.5	0.18
	300	15	3.8	26.7	0.84	11.0	0.35	9.3	0.29	21.3	0.67	8.8	0.28	7.5	0.23	16.0	0.50	6.6	0.21	5.6	0.18	10.7	0.33	4.4	0.14	3.8	0.12
	100	5	1.7	29.1	0.30	12.5	0.13	10.8	0.11	23.3	0.24	10.0	0.10	8.5	0.09	17.4	0.18	7.5	0.08	6.5	0.07	11.6	0.12	5.0	0.05	4.3	0.04

MA 50				LOAD																							
				50 kN				35 kN				25 kN				10 kN											
				RATIO			T ₁ Nm	P ₁ kW	RATIO			T ₁ Nm	P ₁ kW	RATIO			T ₁ Nm	P ₁ kW	RATIO			T ₁ Nm	P ₁ kW				
n ₁ [rpm]	LINEAR SPEED v [mm/s]			RV3	RN3	RL3			RV3	RN3	RL3			RV3	RN3	RL3			RV3	RN3	RL3			RV3	RN3	RL3	RV3
	RV3	RN3	RL3	T ₁	P ₁	T ₁	P ₁	T ₁	P ₁	T ₁	P ₁	T ₁	P ₁	T ₁	P ₁	T ₁	P ₁	T ₁	P ₁	T ₁	P ₁						
3 000	150	75	37.5			12.8	4.01			16.6	5.22	9.0	2.81	21.4	6.70	11.9	3.73	6.4	2.00	8.6	2.68	4.8	1.49	2.6	0.80		
1 500	75	37.5	18.8	45.9	7.21	26.1	4.10	14.3	2.24	32.1	5.05	18.3	2.87	10.0	1.57	23.0	3.60	13.1	2.05	7.2	1.12	9.2	1.44	5.2	0.82	2.9	0.45
1 000	50	25	12.5	48.5	5.08	27.6	2.88	15.3	1.60	34.0	3.55	19.3	2.02	10.7	1.12	24.3	2.54	13.8	1.44	7.5	0.80	9.7	1.02	5.5	0.58	3.1	0.32
	750	37.5	9.4	49.7	3.90	29.0	2.22	15.8	1.24	34.8	2.73	20.3	1.59	11.1	0.87	24.9	1.95	14.5	1.14	7.9	0.62	10.0	0.78	5.8	0.45	3.2	0.25
	500	25	6.3	52.4	2.74	30.0	1.57	16.7	0.87	36.7	1.92	21.0	1.10	11.7	0.61	26.2	1.37	15.0	0.78	8.4	0.44	10.5	0.55	6.0	0.31	3.4	0.17
	300	15	3.8	55.4	1.74	31.6	0.99	18.2	0.57	38.8	1.22	22.1	0.69	12.7	0.40	27.7	0.87	15.8	0.50	9.1	0.28	11.1	0.35	6.3	0.20	3.6	0.11
	100	5	2.5	59.4	0.62	38.8	0.37	20.7	0.22	41.6	0.44	24.7	0.26	14.5	0.15	29.7	0.31	17.7	0.18	10.4	0.11	11.9	0.12	7.1	0.07	4.2	0.04

MA 80				LOAD																							
				80 kN				60 kN				40 kN				20 kN											
				RATIO			T ₁ Nm	P ₁ kW	RATIO			T ₁ Nm	P ₁ kW	RATIO			T ₁ Nm	P ₁ kW	RATIO			T ₁ Nm	P ₁ kW				
n ₁ [rpm]	LINEAR SPEED v [mm/s]			RV3	RN3	RL3			RV3	RN3	RL3			RV3	RN3	RL3			RV3	RN3	RL3			RV3	RN3	RL3	RV3
	RV3	RN3	RL3	T ₁	P ₁	T ₁	P ₁	T ₁	P ₁	T ₁	P ₁	T ₁	P ₁	T ₁	P ₁	T ₁	P ₁	T ₁	P ₁	T ₁	P ₁						
3 000	193	96.4	48.2																								
1 500	96.4	48.2	24.1																								
1 000	64.3	32.1	16.1			56.7	5.93	34.9	3.65	74.4	7.69	42.5	4.45	26.1	2.74	49.6	5.19	28.3	2.97	17.6	1.82	24.8	2.60	14.2	1.48	8.7	0.91
	750	48.2	12.1	102	7.98	59.8	4.69	36.3	2.85	76.2	5.99	44.8	3.52	27.2	2.14	50.8	3.99	29.9	2.35	18.2	1.42	25.4	2.00	15.0	1.17	9.1	0.71
	500	32.1	8.0	107	5.50	62.4	3.27	38.0	1.99	79.8	4.18	46.8	2.45	28.5	1.49	53.2	2.78	31.2	1.63	19.0	0.99	26.6	1.39	15.6	0.82	9.5	0.50
	300	19.3	4.8	115	3.62	65.8	2.07	41.4	1.30	86.4	2.71	49.4	1.55	31.1	0.98	57.6	1.81	32.9	1.03	20.7	0.65	28.8	0.90	16.5	0.52	10.4	0.33
	100	6.4	3.2	125	1.31	74.4	0.78	47.4	0.50	93.8	0.98	55.8	0.58	35.6	0.37	62.5	0.65	37.2	0.39	23.7	0.25	31.3	0.33	18.6	0.19	11.9	0.12

Screw jacks MA Series - travelling screw (Mod.A)

- 3-starts acme screw -

Following tables show the screw jack LINEAR SPEED v [mm/s] and relative TORQUE T_1 [Nm] and POWER P_1 [kW] on input shaft, with reference to the INPUT SPEED n_1 [rpm], the RATIO (RV, RN, RL) and the LOAD [kN] applied on the screw jack.

Intermediate values for linear speed v , torque T_1 and power P_1 at different input speed can be calculated by linear interpolation of the figures stated in the table.

The figures in the tables refer to work with max. duty cycle of 40 % over 10 min time period or 30 % over 1 hour time period at 25°C environment temperature.

ATTENTION! The figures in the **red shaded area** indicate operational restrictions due to thermal limits. When the selection is made within such area, the duty cycle must be reduced or the greater size screw jack must be selected, in order to allow effective heat dissipation. For a better evaluation, please contact SERVOMECH Engineering Dpt.

MA 100				LOAD																							
				100 kN						80 kN						50 kN				20 kN							
n_1 [rpm]	LINEAR SPEED v [mm/s]			RATIO						RATIO						RATIO				RATIO							
	RV3	RN3	RL3	RV3		RN3		RL3		RV3		RN3		RL3		RV3		RN3		RL3		RV3		RN3		RL3	
				T_1 Nm	P_1 kW	T_1 Nm	P_1 kW	T_1 Nm	P_1 kW	T_1 Nm	P_1 kW	T_1 Nm	P_1 kW	T_1 Nm	P_1 kW	T_1 Nm	P_1 kW	T_1 Nm	P_1 kW	T_1 Nm	P_1 kW	T_1 Nm	P_1 kW	T_1 Nm	P_1 kW	T_1 Nm	P_1 kW
3 000	225	75	56.3											29.0	9.10			23.0	7.20	18.1	5.69	24.3	7.63	9.2	2.88	7.3	2.28
1 500	113	37.5	28.1			49.9	7.84	40.3	6.33			39.9	6.27	32.3	5.06	65.2	10.3	25.0	3.92	20.2	3.16	26.1	4.10	10.0	1.57	8.06	1.27
1 000	75	25	18.8			53.9	5.64	43.4	4.55			43.1	4.51	34.8	3.64	68.6	7.18	26.9	2.82	21.7	2.27	27.4	2.87	10.8	1.13	8.68	0.91
750	56.3	18.8	14.1			56.1	4.40	44.2	3.47	113	8.84	44.9	3.52	35.3	2.77	70.4	5.52	28.0	2.20	22.1	1.73	28.2	2.21	11.2	0.88	8.83	0.69
500	37.5	12.5	9.4	148	7.62	57.9	3.03	46.6	2.44	118	6.17	46.3	2.43	37.3	1.95	73.7	3.86	29.0	1.52	23.3	1.22	29.5	1.54	11.6	0.61	9.32	0.49
300	22.5	7.5	5.6	158	4.95	62.2	1.95	51.4	1.61	126	3.96	49.7	1.56	41.1	1.29	78.8	2.47	31.1	0.98	25.7	0.81	31.5	0.99	12.5	0.39	10.3	0.32
100	7.5	2.5	1.9	169	1.77	70.1	0.73	58.7	0.61	136	1.42	56.1	0.59	47.0	0.49	84.6	0.39	35.1	0.37	29.4	0.31	33.9	0.35	14.0	0.15	11.8	0.12

MA 200				LOAD																							
				200 kN						150 kN						100 kN				50 kN							
n_1 [rpm]	LINEAR SPEED v [mm/s]			RATIO						RATIO						RATIO				RATIO							
	RV3	RN3	RL3	RV3		RN3		RL3		RV3		RN3		RL3		RV3		RN3		RL3		RV3		RN3		RL3	
				T_1 Nm	P_1 kW	T_1 Nm	P_1 kW	T_1 Nm	P_1 kW	T_1 Nm	P_1 kW	T_1 Nm	P_1 kW	T_1 Nm	P_1 kW	T_1 Nm	P_1 kW	T_1 Nm	P_1 kW	T_1 Nm	P_1 kW	T_1 Nm	P_1 kW	T_1 Nm	P_1 kW	T_1 Nm	P_1 kW
3 000	225	75	56.3																								
1 500	113	37.5	28.1					87.4	13.8			82.0	12.9	65.6	10.3			54.7	8.58	43.7	6.87	66.7	10.5	27.3	4.29	21.9	3.43
1 000	75	25	18.8			117	12.2	94.9	9.94			87.6	9.17	71.2	7.45	141	14.8	58.4	6.11	47.5	4.97	70.4	7.37	29.2	3.06	23.7	2.48
750	56.3	18.8	14.1			124	9.69	99.6	7.82	217	17.0	92.6	7.27	74.7	5.86	144	11.4	61.7	4.85	49.8	3.91	72.1	5.66	30.9	2.42	24.9	1.95
500	37.5	12.5	9.4			131	6.87	104	5.46	229	12.0	98.4	5.15	78.2	4.09	153	7.98	65.6	3.43	52.1	2.73	76.2	3.99	32.8	1.72	26.1	1.36
300	22.5	7.5	5.6	325	10.2	140	4.39	114	3.58	244	7.66	105	3.29	85.4	2.68	163	5.11	69.9	2.20	57.0	1.79	81.3	2.55	35.0	1.10	28.5	0.89
100	7.5	2.5	1.9	355	3.71	160	1.67	130	1.36	266	2.75	120	1.25	97.3	1.02	177	11.9	80.0	0.83	64.9	0.68	88.6	0.93	39.9	0.42	32.4	0.34

MA 350				LOAD																							
				350 kN						250 kN						150 kN				100 kN							
n_1 [rpm]	LINEAR SPEED v [mm/s]			RATIO						RATIO						RATIO				RATIO							
	RV3	RN3	RL3	RV3		RN3		RL3		RV3		RN3		RL3		RV3		RN3		RL3		RV3		RN3		RL3	
				T_1 Nm	P_1 kW	T_1 Nm	P_1 kW	T_1 Nm	P_1 kW	T_1 Nm	P_1 kW	T_1 Nm	P_1 kW	T_1 Nm	P_1 kW	T_1 Nm	P_1 kW	T_1 Nm	P_1 kW	T_1 Nm	P_1 kW	T_1 Nm	P_1 kW	T_1 Nm	P_1 kW	T_1 Nm	P_1 kW
3 000	225	150	75																								
1 500	113	75	37.5											142	22.3			146	22.9	85.2	13.4	137	21.4	97.0	15.3	56.8	8.91
1 000	75	50	25					214	22.4			257	26.9	153	16.0	214	22.4	154	16.1	91.6	9.59	143	15.0	103	10.8	61.1	6.39
750	56.3	37.5	18.8					227	17.9	371	29.2	267	21.0	163	12.8	223	17.5	160	12.6	97.4	7.65	149	11.7	107	8.38	64.9	5.10
500	37.5	25	12.5	547	28.6	401	21.0	242	12.7	390	20.5	287	15.0	173	9.03	234	12.3	172	9.00	104	5.42	156	8.17	115	6.00	69.0	3.61
300	22.5	15	7.5	588	18.5	428	13.5	252	7.91	420	13.2	306	9.59	180	5.65	252	7.91	183	5.76	108	3.39	167	5.27	112	3.84	72.0	2.26
100	7.5	5	2.5	626	6.55	477	4.99	302	3.16	447	4.68	341	3.57	216	2.26	268	2.81	205	2.14	129	1.35	179	1.87	137	1.43	86.2	0.90

Screw jacks MA Series

Screw jacks MA Series with 4-starts acme screw TECHNICAL SPECIFICATIONS

SCREW JACK SIZE		MA 25	MA 50	MA 80	MA 100	MA 200	MA 350	
Load capacity [kN], (push - pull)		25	50	80	100	200	350	
3-starts acme screw		Tr 30x24 (P6)	Tr 40x28 (P7)	Tr 55x36 (P9)	Tr 60x48 (P12)	Tr 70x48 (P12)	Tr 100x64 (P16)	
Worm gear centre distance [mm]		50	63	63	80	100	125	
Available ratio	RV	1 : 6 (4 : 24)	1 : 7 (4 : 28)	1 : 7 (4 : 28)	1 : 8 (4 : 32)	1 : 8 (4 : 32)	3 : 32	
	RN	1 : 18 (2 : 36)	1 : 14 (2 : 28)	1 : 14 (2 : 28)	1 : 24	1 : 24	1 : 16 (2 : 32)	
	RL	1 : 24	1 : 28	1 : 28	1 : 32	1 : 32	1 : 32	
Stroke [mm] for 1 input shaft revolution	Ratio							
	RV4	4	4	5.14	6	6	6	
	RN4	1.33	2	2.57	2	2	4	
Starting efficiency	Ratio							
	RV4	0.40	0.40	0.37	0.39	0.37	0.35	
	RN4	0.30	0.32	0.31	0.27	0.26	0.31	
Running efficiency at 3000 rpm ⁽¹⁾	Ratio							
	RV4	0.60	0.61	0.60	0.62	0.61	0.60	
	RN4	0.52	0.54	0.54	0.52	0.51	0.57	
Starting torque on input shaft at max. load [Nm]	Ratio							
	RV4	41	81	177	245	513	960	
	RN4	18	51	107	117	244	709	
Max. permissible operating power [kW] ⁽²⁾	Ratio							
	RV4	1.9	3.9	3.9	4.5	7.2	12.3	
	RN4	1.2	2.8	2.8	4.2	6.5	11.5	
Reactive torque on acme screw (nut) required at max. load [Nm]	Ratio							
	RV4	1	2.1	2.1	3.7	6.3	11	
	RL4	149	363	765	1 190	2 510	6 000	
Gear box material		fusione in ghisa sferoidale EN-GJS-500-7 (UNI EN 1563)						
Mass of screw jack without acme screw [kg]		13	26	26	48	75	145	
Mass for every 100 mm of acme screw [kg]		0.45	0.8	1.6	1.8	2.5	5.2	

⁽¹⁾ - efficiency figures at different input speed on page 36

⁽²⁾ - THERMAL limit, referred to work with max. duty cycle 40 % over 10 min time period (30 % over 1 hour time period) at 25°C environment temperature

Screw jacks MA Series - travelling screw (Mod.A)

- 4-starts acme screw -

Following tables show the screw jack LINEAR SPEED v [mm/s] and relative TORQUE T_1 [Nm] and POWER P_1 [kW] on input shaft, with reference to the INPUT SPEED n_1 [rpm], the RATIO (RV, RN, RL) and the LOAD [kN] applied on the screw jack.

Intermediate values for linear speed v , torque T_1 and power P_1 at different input speed can be calculated by linear interpolation of the figures stated in the table.

The figures in the tables refer to work with max. duty cycle of 40 % over 10 min time period or 30 % over 1 hour time period at 25°C environment temperature.

ATTENTION! The figures in the **red shaded area** indicate operational restrictions due to thermal limits. When the selection is made within such area, the duty cycle must be reduced or the greater size screw jack must be selected, in order to allow effective heat dissipation. For a better evaluation, please contact SERVOMECH Engineering Dpt.

MA 25				LOAD																							
				25 kN						20 kN						15 kN				10 kN							
n_1 [rpm]	LINEAR SPEED v [mm/s]			RATIO						RATIO						RATIO				RATIO							
	RV4	RN4	RL4	RV4		RN4		RL4		RV4		RN4		RL4		RV4		RN4		RL4		RV4		RN4		RL4	
				T_1 Nm	P_1 kW	T_1 Nm	P_1 kW	T_1 Nm	P_1 kW	T_1 Nm	P_1 kW	T_1 Nm	P_1 kW	T_1 Nm	P_1 kW	T_1 Nm	P_1 kW	T_1 Nm	P_1 kW	T_1 Nm	P_1 kW	T_1 Nm	P_1 kW	T_1 Nm	P_1 kW	T_1 Nm	P_1 kW
3 000	200	66.7	50									8.2	2.58	6.7	2.11			6.16	1.94	5.1	1.58	10.7	3.34	4.1	1.29	3.4	1.05
1 500	100	33.3	25	28.3	4.44	11.4	1.78	9.3	1.46	22.7	3.56	9.1	1.42	7.5	1.17	17.0	2.67	6.80	1.07	5.6	0.88	11.3	1.78	4.6	0.71	3.7	0.58
1 000	66.7	22.2	16.7	29.3	3.06	11.9	1.24	9.7	1.02	23.4	2.45	9.5	1.00	7.8	0.81	17.6	1.84	7.13	0.75	5.8	0.61	11.7	1.23	4.8	0.50	3.9	0.41
750	50	16.7	12.5	30.0	2.35	12.3	0.96	10.1	0.79	24.0	1.88	9.8	0.77	8.1	0.63	18.0	1.41	7.34	0.58	6.0	0.47	12.0	0.94	4.9	0.38	4.0	0.32
500	33.3	11.1	8.3	31.6	1.65	12.9	0.67	10.7	0.56	25.3	1.32	10.3	0.54	8.6	0.45	19.0	0.99	7.70	0.40	6.5	0.34	12.6	0.66	5.2	0.27	4.3	0.22
300	20	6.7	5	32.8	1.03	13.5	0.42	11.4	0.36	26.3	0.82	10.8	0.34	9.2	0.29	19.7	0.62	8.10	0.25	6.9	0.22	13.1	0.41	5.4	0.17	4.6	0.14
100	6.7	2.2	1.7	35.6	0.37	15.2	0.16	13.1	0.14	28.5	0.30	12.2	0.13	10.5	0.11	21.4	0.22	9.12	0.10	7.9	0.08	14.3	0.15	6.1	0.06	5.3	0.05

MA 50				LOAD																							
				50 kN						35 kN						25 kN				10 kN							
n_1 [rpm]	LINEAR SPEED v [mm/s]			RATIO						RATIO						RATIO				RATIO							
	RV4	RN4	RL4	RV4		RN4		RL4		RV4		RN4		RL4		RV4		RN4		RL4		RV4		RN4		RL4	
				T_1 Nm	P_1 kW	T_1 Nm	P_1 kW	T_1 Nm	P_1 kW	T_1 Nm	P_1 kW	T_1 Nm	P_1 kW	T_1 Nm	P_1 kW	T_1 Nm	P_1 kW	T_1 Nm	P_1 kW	T_1 Nm	P_1 kW	T_1 Nm	P_1 kW	T_1 Nm	P_1 kW	T_1 Nm	P_1 kW
3 000	200	100	50									20.7	6.49	11.9	3.74	26.1	8.21	14.8	4.63	8.5	2.67	10.5	3.28	5.9	1.85	3.4	1.07
1 500	100	50	25	55.6	8.73	32.2	5.05	19.1	2.99	38.9	6.11	22.5	3.53	13.4	2.09	27.8	4.36	16.1	2.52	9.5	1.50	11.1	1.75	6.5	1.01	3.8	0.60
1 000	66.7	33.3	16.7	58.2	6.09	33.8	3.54	20.4	2.14	40.7	4.26	23.7	2.48	14.3	1.50	29.1	3.05	16.9	1.77	10.2	1.07	11.7	1.22	6.8	0.71	4.1	0.43
750	50	25	12.5	59.4	4.66	35.4	2.78	21.1	1.65	41.6	3.26	24.8	1.95	14.8	1.16	29.7	2.33	17.7	1.39	10.5	0.83	11.9	0.93	7.1	0.56	4.2	0.33
500	33.3	16.7	8.3	62.0	3.25	36.6	1.91	22.3	1.16	43.4	2.27	25.6	1.34	15.6	0.81	31.0	1.62	18.3	0.96	11.1	0.58	12.4	0.65	7.3	0.38	4.5	0.23
300	20	10	5	65.2	2.05	38.5	1.21	24.2	0.76	45.6	1.43	27.0	0.85	16.9	0.53	32.6	1.02	19.3	0.60	12.1	0.38	13.1	0.41	7.7	0.24	4.9	0.15
100	6.7	3.3	1.7	69.5	0.73	42.8	0.45	27.6	0.29	48.7	0.51	29.9	0.31	19.9	0.20	34.8	0.36	21.4	0.22	13.8	0.14	13.9	0.15	8.6	0.09	5.5	0.06

MA 80				LOAD																								
				80 kN						60 kN						40 kN				20 kN								
n_1 [rpm]	LINEAR SPEED v [mm/s]			RATIO						RATIO						RATIO				RATIO								
	RV4	RN4	RL4	RV4		RN4		RL4		RV4		RN4		RL4		RV4		RN4		RL4		RV4		RN4		RL4		
				T_1 Nm	P_1 kW	T_1 Nm	P_1 kW	T_1 Nm	P_1 kW	T_1 Nm	P_1 kW	T_1 Nm	P_1 kW	T_1 Nm	P_1 kW	T_1 Nm	P_1 kW	T_1 Nm	P_1 kW	T_1 Nm	P_1 kW	T_1 Nm	P_1 kW	T_1 Nm	P_1 kW	T_1 Nm	P_1 kW	
3 000	257	129	64.3																									
1 500	129	64.3	32.1											29.3	4.60	58.8	9.23	32.7	5.14	19.6	3.07	29.4	4.62	16.4	2.57	9.8	1.53	
1 000	85.7	42.9	21.4					42.4	4.44	92.0	9.63	52.1	5.45	31.8	3.33	61.3	6.42	34.7	3.64	21.2	2.22	30.7	3.21	17.4	1.82	10.6	1.11	
750	64.3	32.1	16.1	126	9.84	73.0	5.73	44.0	3.46	94.0	7.38	54.7	4.30	33.0	2.59	62.7	4.92	36.5	2.86	22.0	1.73	31.3	2.46	18.3	1.43	11.0	0.86	
500	42.9	21.4	10.7	131	6.84	76.0	3.98	46.1	2.41	98.0	5.13	57.0	2.98	34.6	1.81	65.3	3.42	38.0	1.99	23.0	1.21	32.7	1.71	19.0	0.99	11.5	0.60	
300	25.7	12.9	6.4	141	4.41	79.9	2.51	50.1	1.57	106	3.31	59.9	1.88	37.6	1.18	70.2	2.20	39.9	1.25	25.0	0.79	35.1	1.10	20.0	0.63	12.5	0.39	
100	4.3	4.3	2.1	152	1.58	89.6	0.94	57.0	0.60	114	1.19	67.2	0.70	42.8	0.45	75.6	0.79	44.8	0.47	28.5	0.30	37.8	0.40	22.4	0.23	14.3	0.15	

Screw jacks MA Series - travelling screw (Mod.A)

- 4-starts acme screw -

Following tables show the screw jack LINEAR SPEED v [mm/s] and relative TORQUE T_1 [Nm] and POWER P_1 [kW] on input shaft, with reference to the INPUT SPEED n_1 [rpm], the RATIO (RV, RN, RL) and the LOAD [kN] applied on the screw jack.

Intermediate values for linear speed v , torque T_1 and power P_1 at different input speed can be calculated by linear interpolation of the figures stated in the table.

The figures in the tables refer to work with max. duty cycle of 40 % over 10 min time period or 30 % over 1 hour time period at 25°C environment temperature.

ATTENTION! The figures in the **red shaded area** indicate operational restrictions due to thermal limits. When the selection is made within such area, the duty cycle must be reduced or the greater size screw jack must be selected, in order to allow effective heat dissipation. For a better evaluation, please contact SERVOMECH Engineering Dpt.

MA 100				LOAD																							
				100 kN				80 kN				50 kN				20 kN											
				RV4		RN4		RL4		RV4		RN4		RL4		RV4		RN4		RL4							
n_1 [rpm]	LINEAR SPEED v [mm/s]			T_1 Nm		P_1 kW		T_1 Nm		P_1 kW		T_1 Nm		P_1 kW		T_1 Nm		P_1 kW									
	RV4	RN4	RL4																								
3 000	300	100	75													30.6	9.60	24.2	7.58	30.9	9.69	12.3	3.84	9.7	3.03		
1 500	150	50	37.5			66.6	10.5	53.7	8.44			53.2	8.36	43.0	6.75			33.3	5.23	26.9	4.22	32.9	5.16	13.3	2.09	10.8	1.69
1 000	100	33.3	25			71.8	7.52	57.9	6.06			57.4	6.01	46.3	4.85	85.8	8.99	35.9	3.76	29.0	3.03	34.4	3.59	14.4	1.50	11.6	1.21
	750	75	18.8			74.7	5.87	58.9	4.62	141	11.1	59.8	4.69	47.1	3.70	87.9	6.90	37.4	2.93	29.5	2.31	35.2	2.76	15.0	1.17	11.8	0.92
	500	50	12.5	183	9.58	77.2	4.04	62.2	3.25	147	7.67	61.8	3.23	49.8	2.60	91.5	4.79	38.6	2.02	31.1	1.63	36.6	1.92	15.5	0.81	12.5	0.65
	300	30	7.5	195	6.11	82.9	2.60	68.5	2.15	156	4.89	66.3	2.08	54.8	1.72	97.3	3.05	41.7	1.30	34.3	1.08	38.9	1.22	16.6	0.52	13.7	0.43
	100	10	2.5	208	2.18	93.5	0.98	78.2	0.82	167	1.74	74.8	0.78	62.6	0.66	104	1.09	46.8	0.49	39.1	0.41	41.6	0.44	18.7	0.20	15.7	0.16

MA 200				LOAD																							
				200 kN				150 kN				100 kN				50 kN											
				RV4		RN4		RL4		RV4		RN4		RL4		RV4		RN4		RL4							
n_1 [rpm]	LINEAR SPEED v [mm/s]			T_1 Nm		P_1 kW		T_1 Nm		P_1 kW		T_1 Nm		P_1 kW		T_1 Nm		P_1 kW									
	RV4	RN4	RL4																								
3 000	300	100	75													49.3	15.5					31.3	9.81	24.7	7.75		
1 500	150	50	37.5							101	15.9	80.5	12.7			67.4	10.6	53.7	8.43	83.3	13.1	33.7	5.29	26.8	4.21		
1 000	100	33.3	25			144	15.0	116	12.2			108	11.3	86.9	9.10			71.6	7.50	57.9	6.07	87.4	9.15	35.8	3.75	29.0	3.03
	750	75	18.8			151	11.9	122	9.54			113	8.87	91.1	7.15	179	14.1	75.3	5.92	60.7	4.77	89.4	7.02	37.7	2.96	30.4	2.38
	500	50	12.5			160	8.37	127	6.64	282	14.8	120	6.28	95.2	4.98	188	9.82	80.0	4.19	63.4	3.32	93.8	4.91	40.0	2.09	31.7	1.66
	300	30	7.5	398	12.5	170	5.33	138	4.34	299	9.38	128	4.00	104	3.25	199	6.25	84.9	2.67	69.1	2.17	99.5	3.13	42.4	1.33	34.5	1.08
	100	10	2.5	431	4.51	193	2.02	157	1.64	323	3.38	145	1.51	118	1.23	215	2.25	96.4	1.01	78.3	0.82	108	1.13	48.2	0.50	39.2	0.41

MA 350				LOAD																							
				350 kN				250 kN				150 kN				100 kN											
				RV4		RN4		RL4		RV4		RN4		RL4		RV4		RN4		RL4							
n_1 [rpm]	LINEAR SPEED v [mm/s]			T_1 Nm		P_1 kW		T_1 Nm		P_1 kW		T_1 Nm		P_1 kW		T_1 Nm		P_1 kW									
	RV4	RN4	RL4																								
3 000	300	200	100																						63.6	20.0	
1 500	150	100	50									174	27.4			180	28.3	105	16.4	170	26.7	120	18.9	69.6	11.0		
1 000	100	66.7	33.3					261	27.3			187	19.5	265	27.8	190	19.9	112	11.7	177	18.5	127	13.3	74.6	7.80		
	750	75	25					276	21.7			328	25.7	197	15.5	275	21.6	197	15.5	118	9.29	184	14.4	131	10.3	78.9	6.19
	500	50	16.7			489	25.6	293	15.3	479	25.1	349	18.3	209	11.0	287	15.1	210	11.0	126	6.56	192	10.1	140	7.31	83.6	4.38
	300	30	10	716	22.5	519	16.3	306	9.59	511	16.1	371	11.7	218	6.85	307	9.63	221	6.98	131	4.41	205	6.42	148	4.66	87.3	2.74
	100	10	3.3	759	7.94	576	6.03	362	3.79	542	5.67	411	4.31	259	2.71	325	3.40	247	2.58	155	1.62	217	2.22	165	1.72	104	1.08

Screw jacks MA Series - overall dimensions

Model A - TRAVELLING SCREW

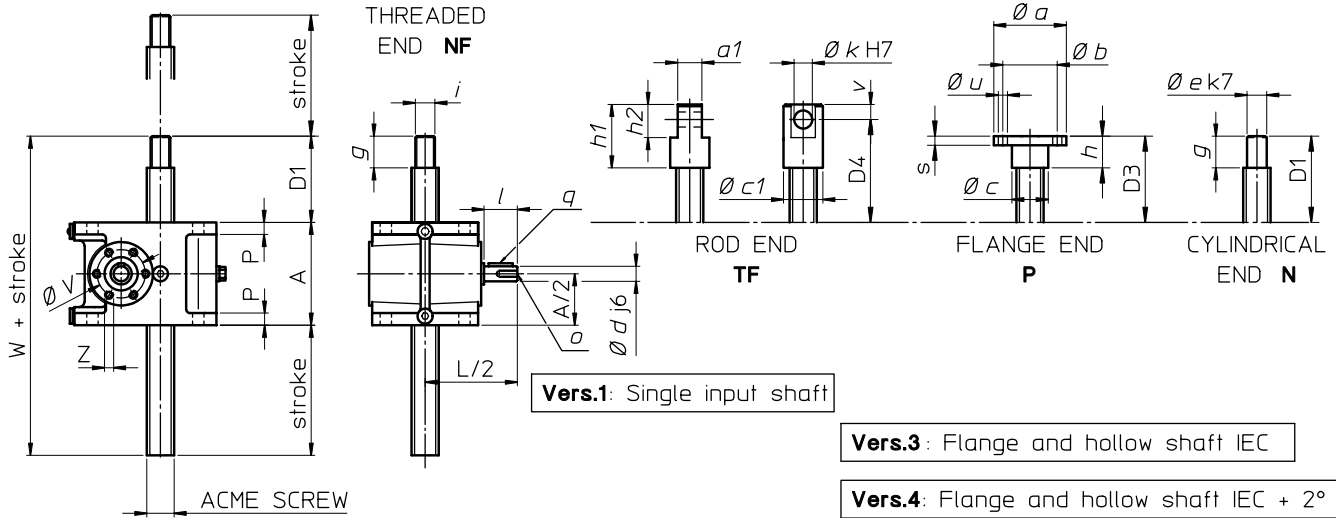

Vers.1: Single input shaft

Vers.3: Flange and hollow shaft IEC

Vers.4: Flange and hollow shaft IEC + 2° shaft

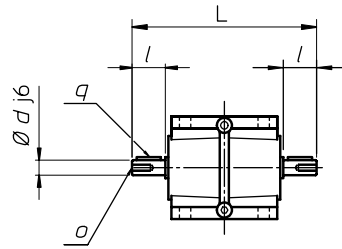
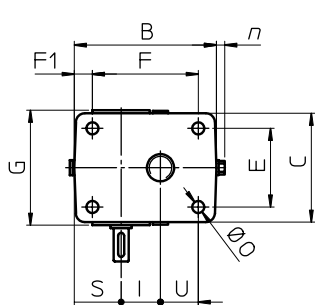

Vers.2: Double free input shaft

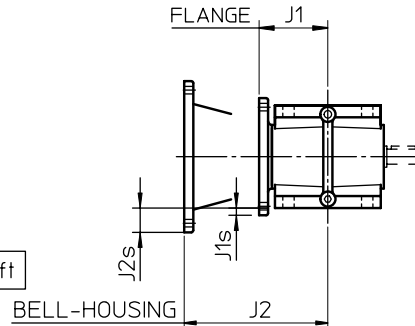

Vers.5: Vers.1 + bell-housing and coupling IEC

Vers.6: Vers.2 + bell-housing and coupling IEC

Model B - TRAVELLING NUT

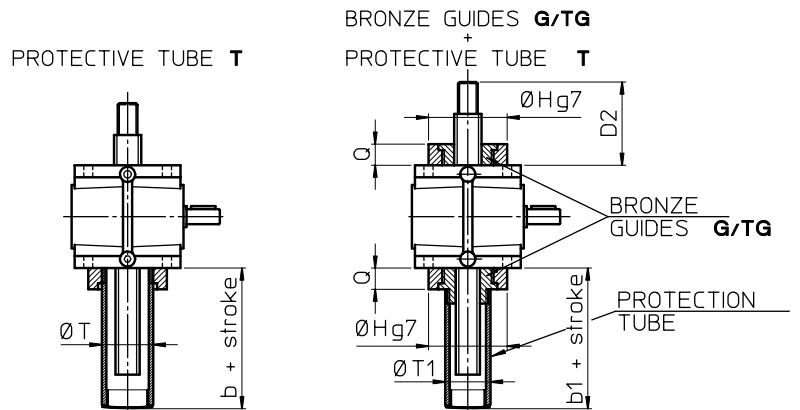
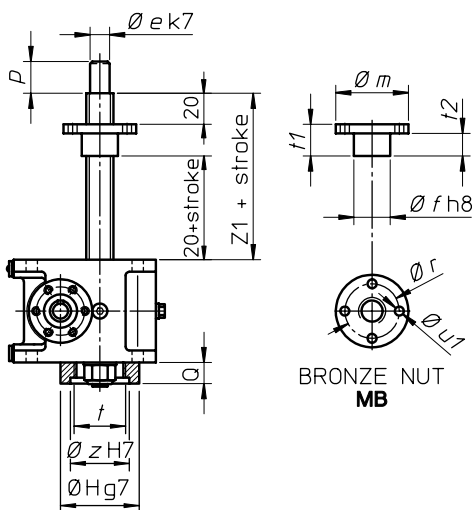

SIZE	MA 5	MA 10	MA 25	MA 50	MA 80	MA 100	MA 200	MA 350	
ØT	50 (*)	55	70	90	90	110	150	180	
b	exec. T	25	25	25	25	35	35	35	
	exec. T + SN	75	75	105	105	105	115	135	
	exec. T + AR	80	85	95	95	95	90	100	
	exec. T + FCM	82	86	-	-	-	-	-	
	exec. T + FCP	85	86	94	96	96	100	105	110
	exec. T+AR+FCP	90	96	115	117	117	115	120	140
ØT1	40 (*)	50 (*)	60 (*)	60 (*)	100 (*)	100 (*)	100 (*)	160	
b1	exec. TG	50	51	59	61	61	65	90	125
	exec. TG + FCM	100	101	115	117	-	-	-	-
	exec. TG + FCP	100	101	109	111	111	115	140	165

* - for executions WITHOUT FCP: the actual value will be smaller

Screw jacks MA Series - overall dimensions

SIZE	MA 5	MA 10	MA 25	MA 50	MA 80	MA 100	MA 200	MA 350
ACME SCREW	Tr 18x4	Tr 22x 5	Tr 30x6	Tr 40x7	Tr 55x9	Tr 60x12	Tr 70x12	Tr 100x16
A	80	100	126	160	160	200	230	280
B	124	140	175	235	235	276	330	415
C	80	105	130	160	160	200	230	300
D1 (min.)	39	44	58	58	68	68	78	98
D2 (min.)	54	60	82	84	94	98	113	138
D3 (min.)	40	45	60	60	70	70	80	100
D4 (min.)	65	75	95	105	120	150	170	220
E	62	80	100	120	120	150	175	230
F	95	110	140	190	190	220	270	330
F1	12.5	14	17.5	23	23	26	30	42
G	100	114	136	165	165	205	256	326
∅ H	65	80	100	120	120	160	190	240
I	30	40	50	63	63	80	100	125
L	149	179	221.5	269	269	330	378	490
∅ O	9	9	13	17	17	21	28	34
P	10	12	15	19	19	22	26	30
Q	15	16	24	26	26	30	35	40
S	46.5	46	57.5	80	80	91	113	121
U	31	38	50	70	70	75	87	126
∅ V	42	46	64	63	63	74	110	118
W	119	144	184	218	228	268	308	378
Z	M5, depth 10	M5, depth 12	M5, depth 10	M6, depth 14	M6, depth 14	M6, depth 14	M10, depth 20	M10, depth 25
Z1	80	85	90	115	140	140	170	200
∅ a	68	75	100	120	150	150	180	250
a1	20	25	30	40	50	60	75	100
∅ b	45	55	75	85	110	110	130	180
∅ c	25	30	40	50	70	70	85	115
∅ c1	32	38	48	68	78	90	108	138
∅ d	10	14	19	24	24	28	32	38
∅ e	12	15	20	30	40	40	50	70
∅ f	30	40	50	60	75	80	100	150
g	19	24	38	38	48	48	58	78
h	20	25	40	40	50	50	60	80
h1	60	75	100	120	140	180	210	280
h2	30	40	50	70	80	100	120	160
i	M12x1.75	M16x1.5	M20x1.5	M30x2	M42x3	M42x3	M56x3	M80x3
∅ k	14	20	25	35	40	50	60	80
l	22	30	40	50	50	60	60	80
∅ m	68	75	100	120	130	150	180	250
n	—	—	10	10	10	12	10	10
o	M5, depth. 10	M6, depth 14	M8, depth 16	M8, depth 16	M8, depth 16	M8, depth 16	M10, depth 24	M12, depth 32
p	19	24	40	40	45	50	60	65
q	3x3x15	5x5x20	6x6x30	8x7x40	8x7x40	8x7x40	10x8x40	10x8x60
∅ r	50	56	75	90	105	120	140	200
s	8	10	12	15	20	20	25	35
t	M45x1.5	M55x1.5	M70x2	M90x2	M90x2	M110x2	M150x3	M180x3
t1	40	45	50	75	100	100	130	160
t2	28	33	35	50	80	70	95	115
∅ u, n° holes	∅ 7, 4 holes	∅ 9, 4 holes	∅ 11, 4 holes	∅ 17, 4 holes	∅ 21, 4 holes	∅ 21, 4 holes	∅ 26, 6 holes	∅ 30, 6 holes
∅ u1, n° holes	∅ 7, 4 holes	∅ 9, 4 holes	∅ 11, 4 holes	∅ 17, 4 holes	∅ 17, 4 holes	∅ 21, 4 holes	∅ 26, 6 holes	∅ 30, 6 holes
v	15	20	25	35	40	50	60	80
w	15	17	25	36	38	41	42	45
∅ z	50	60	77	95	95	120	160	200
J1	63 B5/B14: 62	63 B5/B14: 69	63/71 B5: 102	80 B5: 100	80 B5: 100	80/90 B5: 120	100/112 B5: 142	—
J1s	63 B5: 30 63 B14: 5	63 B5: 20 63 B14: —	63 B5: 7 71 B5: 17	80 B5: 20	80 B5: 20	80/90 B5: —	90 B5: — 100/112 B5: 10	—
J2	71 B5: 122 71 B14: 131	71 B5: 129 71 B14: 138	80 B5: 182 80 B14: 176 90 B5: 182 90 B14: 182	90 B5: 200 90 B14: 200 100 B5: 220 100 B14: 220	90 B5: 200 90 B14: 200 100/112 B5: 220 100/112 B14: 220	100/112 B5 240 100/112 B14: 240	132 B5: 297	—
J2s	71 B5: 40 71 B14: 12.5	71 B5: 30 71 B14: 3	80 B5: 37 80 B14: — 90 B5: 37 90 B14: 7	90 B5: 20 90 B14: — 100 B5: 45 100 B14: —	90 B5: 20 90 B14: — 100/112 B5: 45 100/112 B14: —	100/112 B5 25 100/112 B14: —	132 B5: 35	—

Screw jacks MA Series

Total efficiency of screw jack with 1-start acme screw

η	MA 5			MA 10			MA 25			MA 50			MA 80			MA 100			MA 200			MA 350					
	RATIO			RATIO			RATIO			RATIO			RATIO			RATIO			RATIO			RATIO					
n_1 [rpm]	RV1	RN1	RL1	RV1	RN1	RL1	RV1	RN1	RL1	RV1	RN1	RL1	RV1	RN1	RL1	RV1	RN1	RL1	RV1	RN1	RL1	RV1	RN1	RL1	RV1	RN1	RL1
3 000	0.40	0.31	0.27	0.41	0.30	0.28	0.38	0.30	0.28	0.37	0.32	0.26	0.39	0.33	0.27	0.41	0.32	0.30	0.38	0.31	0.28	0.39	0.34	0.29	0.39	0.34	0.29
1 500	0.36	0.28	0.25	0.37	0.28	0.27	0.34	0.27	0.25	0.32	0.28	0.23	0.34	0.28	0.23	0.36	0.29	0.26	0.33	0.26	0.24	0.32	0.29	0.24	0.32	0.29	0.24
1 000	0.34	0.27	0.24	0.35	0.26	0.25	0.32	0.26	0.24	0.30	0.26	0.22	0.31	0.26	0.21	0.34	0.26	0.25	0.31	0.24	0.23	0.29	0.27	0.23	0.29	0.27	0.23
750	0.33	0.26	0.23	0.34	0.25	0.23	0.31	0.25	0.23	0.29	0.25	0.21	0.30	0.25	0.20	0.32	0.25	0.24	0.30	0.23	0.22	0.28	0.26	0.22	0.28	0.26	0.22
500	0.31	0.25	0.21	0.32	0.24	0.23	0.29	0.24	0.22	0.28	0.24	0.20	0.27	0.23	0.19	0.31	0.24	0.22	0.28	0.22	0.21	0.27	0.25	0.21	0.27	0.25	0.21
300	0.30	0.24	0.20	0.31	0.23	0.22	0.28	0.23	0.20	0.26	0.23	0.18	0.25	0.22	0.17	0.29	0.23	0.21	0.27	0.21	0.19	0.25	0.23	0.19	0.25	0.23	0.19
100	0.28	0.22	0.17	0.29	0.20	0.19	0.26	0.20	0.18	0.24	0.21	0.16	0.24	0.20	0.15	0.27	0.20	0.18	0.24	0.18	0.16	0.22	0.21	0.17	0.22	0.21	0.17
AT START	0.21	0.16	0.13	0.22	0.15	0.14	0.20	0.16	0.13	0.18	0.15	0.11	0.18	0.15	0.11	0.20	0.13	0.12	0.17	0.12	0.11	0.16	0.14	0.10	0.16	0.14	0.10

Total efficiency of screw jack with 2-starts acme screw

η	MA 5			MA 10			MA 25			MA 50			MA 80			MA 100			MA 200			MA 350					
	RATIO			RATIO			RATIO			RATIO			RATIO			RATIO			RATIO			RATIO					
n_1 [rpm]	RV2	RN2	RL2	RV2	RN2	RL2	RV2	RN2	RL2	RV2	RN2	RL2	RV2	RN2	RL2	RV2	RN2	RL2	RV2	RN2	RL2	RV2	RN2	RL2	RV2	RN2	RL2
3 000	0.52	0.41	0.36	0.53	0.40	0.39	0.51	0.43	0.39	0.50	0.44	0.38	0.51	0.44	0.38	0.54	0.43	0.41	0.52	0.42	0.39	0.51	0.48	0.41	0.51	0.48	0.41
1 500	0.48	0.38	0.33	0.49	0.36	0.35	0.47	0.38	0.34	0.46	0.40	0.33	0.46	0.40	0.33	0.49	0.39	0.36	0.48	0.38	0.35	0.46	0.43	0.36	0.46	0.43	0.36
1 000	0.46	0.36	0.31	0.46	0.35	0.33	0.45	0.36	0.33	0.43	0.37	0.30	0.43	0.37	0.30	0.46	0.36	0.33	0.45	0.35	0.32	0.44	0.40	0.33	0.44	0.40	0.33
750	0.44	0.35	0.29	0.44	0.33	0.31	0.44	0.35	0.32	0.42	0.35	0.29	0.42	0.35	0.29	0.45	0.34	0.32	0.43	0.33	0.31	0.42	0.39	0.31	0.42	0.39	0.31
500	0.42	0.33	0.28	0.42	0.31	0.30	0.41	0.33	0.30	0.39	0.34	0.28	0.40	0.33	0.27	0.43	0.33	0.31	0.41	0.31	0.29	0.40	0.35	0.29	0.40	0.35	0.29
300	0.40	0.31	0.26	0.41	0.29	0.28	0.39	0.31	0.27	0.37	0.32	0.25	0.36	0.32	0.25	0.39	0.31	0.27	0.38	0.29	0.27	0.36	0.33	0.28	0.36	0.33	0.28
100	0.37	0.28	0.22	0.37	0.25	0.24	0.35	0.27	0.24	0.34	0.28	0.22	0.33	0.28	0.22	0.36	0.27	0.24	0.34	0.25	0.23	0.34	0.29	0.23	0.34	0.29	0.23
AT START	0.32	0.25	0.20	0.33	0.22	0.21	0.31	0.23	0.20	0.29	0.24	0.18	0.28	0.23	0.17	0.30	0.21	0.19	0.28	0.20	0.18	0.26	0.23	0.18	0.26	0.23	0.18

Total efficiency of screw jack with 3-starts acme screw

η	MA 25			MA 50			MA 80			MA 100			MA 200			MA 350		
	RATIO			RATIO			RATIO			RATIO			RATIO			RATIO		
n_1 [rpm]	RV3	RN3	RL3	RV3	RN3	RL3	RV3	RN3	RL3	RV3	RN3	RL3	RV3	RN3	RL3	RV3	RN3	RL3
3 000	0.57	0.48	0.44	0.56	0.50	0.47	0.57	0.50	0.43	0.59	0.52	0.49	0.58	0.48	0.45	0.57	0.54	0.46
1 500	0.53	0.43	0.40	0.52	0.46	0.42	0.52	0.46	0.38	0.55	0.48	0.44	0.54	0.44	0.41	0.53	0.49	0.42
1 000	0.51	0.41	0.38	0.49	0.43	0.39	0.50	0.43	0.35	0.52	0.44	0.41	0.51	0.41	0.38	0.50	0.47	0.39
750	0.50	0.40	0.37	0.48	0.41	0.38	0.48	0.41	0.34	0.51	0.43	0.41	0.50	0.39	0.36	0.48	0.45	0.37
500	0.47	0.38	0.34	0.46	0.40	0.36	0.46	0.39	0.32	0.49	0.41	0.38	0.47	0.36	0.34	0.46	0.42	0.35
300	0.45	0.36	0.32	0.43	0.38	0.33	0.43	0.37	0.30	0.45	0.38	0.35	0.44	0.34	0.31	0.43	0.39	0.33
100	0.41	0.32	0.28	0.40	0.34	0.29	0.39	0.33	0.26	0.42	0.34	0.31	0.40	0.30	0.28	0.40	0.35	0.28
AT START	0.36	0.28	0.24	0.34	0.29	0.24	0.33	0.28	0.21	0.36	0.27	0.25	0.34	0.24	0.21	0.31	0.28	0.21

Total efficiency of screw jack with 4-starts acme screw

η	MA 25			MA 50			MA 80			MA 100			MA 200			MA 350		
	RATIO			RATIO			RATIO			RATIO			RATIO			RATIO		
n_1 [rpm]	RV4	RN4	RL4	RV4	RN4	RL4	RV4	RN4	RL4	RV4	RN4	RL4	RV4	RN4	RL4	RV4	RN4	RL4
3 000	0.60	0.52	0.47	0.61	0.54	0.47	0.60	0.54	0.47	0.62	0.52	0.49	0.61	0.51	0.48	0.60	0.57	0.50
1 500	0.56	0.47	0.43	0.57	0.50	0.42	0.56	0.50	0.42	0.58	0.48	0.44	0.57	0.47	0.44	0.56	0.53	0.46
1 000	0.54	0.45	0.41	0.55	0.47	0.39	0.53	0.47	0.39	0.56	0.44	0.41	0.55	0.44	0.41	0.54	0.50	0.43
750	0.53	0.43	0.40	0.54	0.45	0.38	0.52	0.45	0.37	0.54	0.43	0.41	0.53	0.42	0.39	0.52	0.49	0.40
500	0.50	0.41	0.37	0.51	0.44	0.36	0.50	0.43	0.36	0.52	0.41	0.38	0.51	0.40	0.38	0.50	0.46	0.38
300	0.49	0.39	0.35	0.49	0.41	0.33	0.47	0.41	0.33	0.49	0.38	0.35	0.48	0.38	0.35	0.47	0.43	0.36
100	0.45	0.35	0.30	0.46	0.37	0.29	0.43	0.37	0.29	0.46	0.34	0.31	0.44	0.33	0.30	0.44	0.39	0.31
AT START	0.40	0.30	0.26	0.40	0.32	0.24	0.37	0.31	0.23	0.39	0.27	0.25	0.37	0.26	0.24	0.35	0.31	0.24

Screw jacks MA Series - options

Cover

The housing of the screw jacks MA Series is enclosed with two covers, one on the top and one on the bottom, available in two executions: CB (low cover) or CA (raised cover).

The raised cover CA allows the fitting of bronze guide bushes or protective tubes. The raised cover CA with toleranced outer diameter acts as a centring register of the screw jack inside the machine structure.

Screw jacks with travelling nut (Mod.B) have raised cover as standard, mounted on the screw jack housing on the opposite side of the acme screw, to protect the rotating threaded screw end.

Ordering code: **CB-CB, CB-CA, CA-CB, CA-CA**
(based on application requirements)

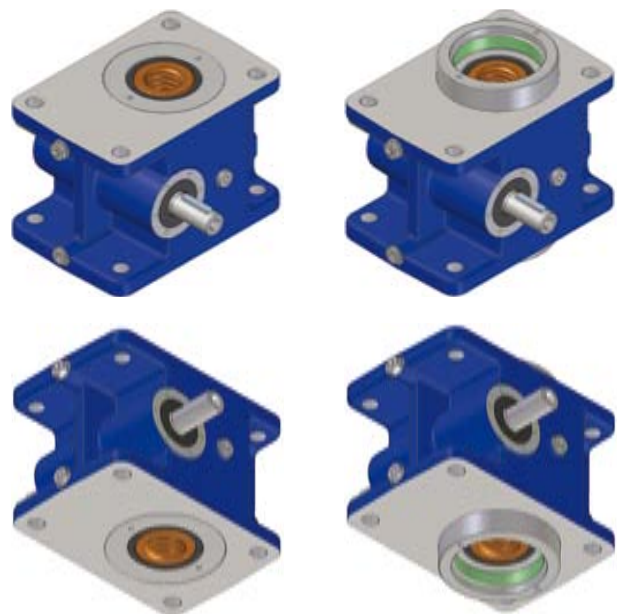

2

Bronze guide

Available for screw jacks with travelling screw (Mod. A) only.

The bronze guide keep the coaxial position of the acme screw with the internal thread of the worm wheel. It is mounted on the raised cover CA **on both sides** of the screw jack housing.

Bronze guides are recommended in case of even low radial load.

Ordering code: **G-G**

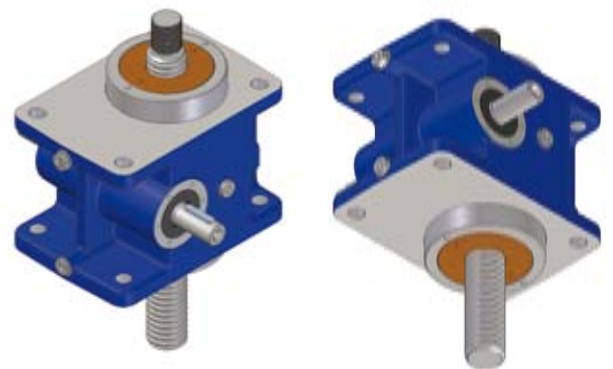

If the screw jack needs a protective tube in addition to the bronze guides, it is screwed to the bronze guide thread.

Ordering code: **G-TG**

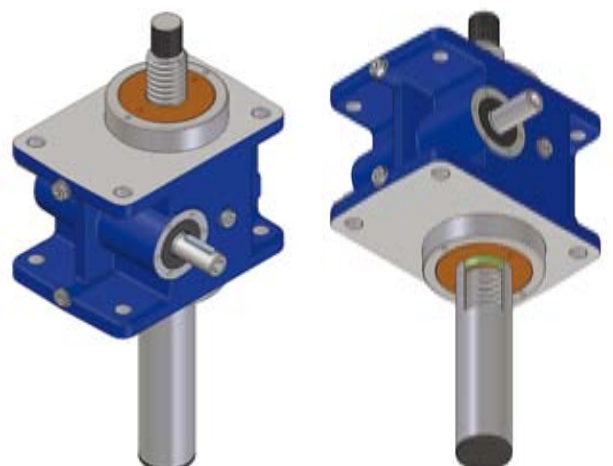

Use of bronze guides is indispensable in applications with trunnion mount!

Stop nut

Available for screw jacks with travelling screw (Mod. A) only.

The mechanical stop prevents the acme screw thread unscrewing clear of the screw jack housing. It is a washer pinned at the acme screw end (opposite the attachment side) that blocks the screw translation when reaching the relative stop.

The acme screw length is defined to allow, under normal use, at the maximum extended position, 20 mm of additional stroke (safety extra-stroke).

If the mechanical stop reaches accidentally the relative stop, it is necessary to check the screw jacks components to verify possible damages.

Ordering code: **SN**

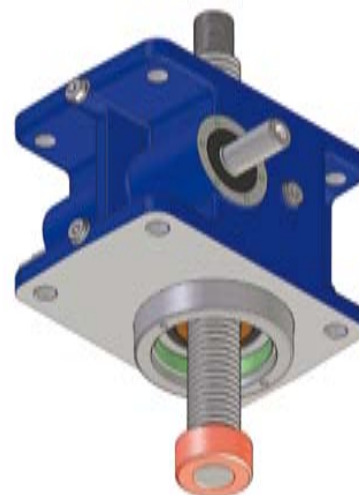

Protective tube

Available for screw jacks with travelling screw (Mod. A) only.

The protective tube is screwed in the raised cover CA and encloses the acme screw below the housing, protecting it from damages and/or environment pollution such as dust, water, etc. Furthermore, it allows the fitting of other options such as limit switches and/or anti-turn device.

Material is aluminium or steel if anti-turn device is fitted.

Ordering code: **T**

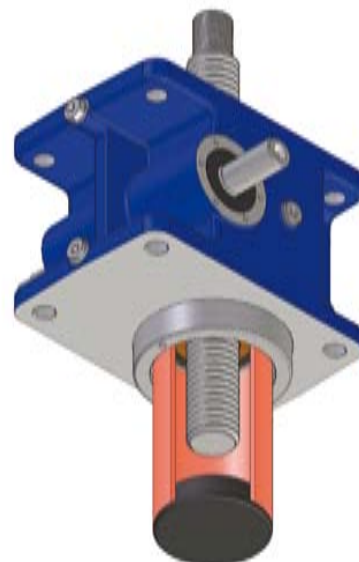

Anti-turn device

Available for screw jacks with travelling screw (Mod. A) only.

The anti-turn device is necessary when the load to be lifted may turn, i.e. the screw guidance does not prevent rotation, or in case the application does not properly allow the acme screw reaction to permit the translation.

Functioning: a steel key is fitted along the protective tube and a keyed bronze washer is fixed at the end of the acme screw; this prevents the screw rotation and forces the screw translation.

Up to screw jack size 50 (acme screw Tr 40x7) included, the anti-turn device has only one key; from size 80 (acme screw Tr 55 x9) on, it has two keys.

The bronze bush also acts as a stop nut against acme screw unthreading.

Ordering code: **AR**

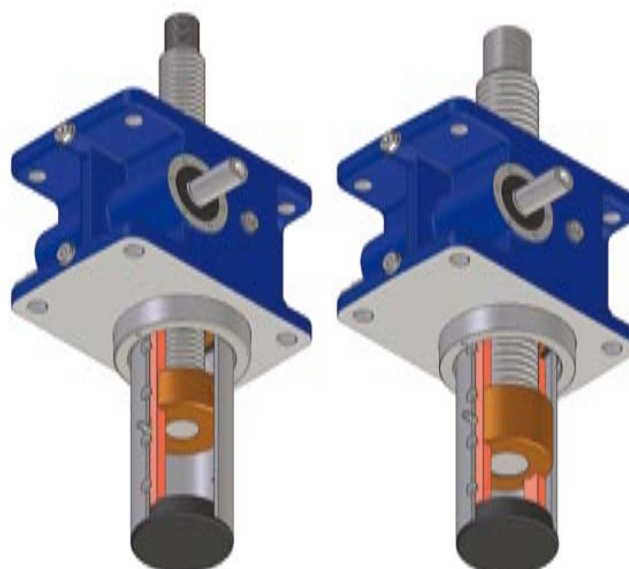

Screw jacks MA Series - options

Trunnion mount

Available for both screw jacks models: with travelling screw (Mod. A) and with travelling nut (Mod. B).

The trunnion mount bolts on to either the top or the bottom of the screw jack housing and allows pivoting of the screw jack around the axis defined by trunnion mount's lateral pins.

On screw jack Mod. A: the acme screw attachment must have a cylindrical hole with axis parallel to the trunnion mount lateral pin axis.

On screw jack Mod. B: the part of the machine where the bronze nut MB is fixed must have two lateral cylindrical pins (or holes) with axis parallel to the trunnion mount lateral pin axis.

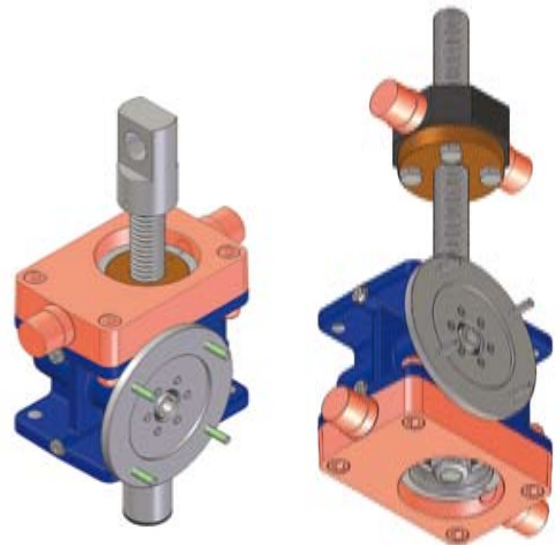
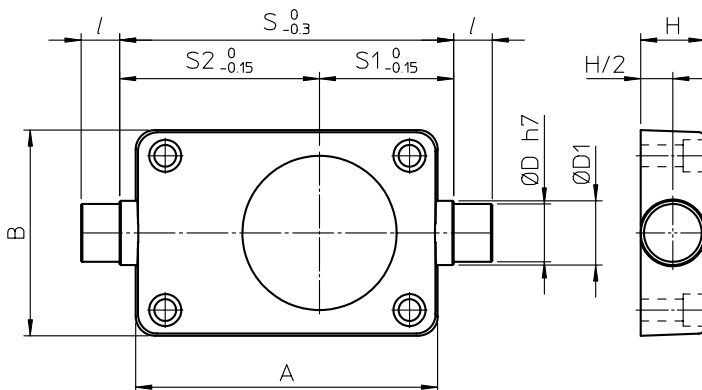

2

	MA 5	MA 10	MA 25	MA 50	MA 80	MA 100	MA 200	MA 350
A	124	140	175	235	235	276	330	415
B	80	105	130	160	160	200	230	300
ØD	15	20	25	45	45	50	70	80
ØD ₁	20	25	30	50	50	60	80	90
H	20	25	30	50	50	60	80	90
l	15	20	20	30	30	40	45	60
S	130	145	200	260	260	305	360	440
S ₁	50.5	56.5	80	104.5	104.5	119.5	132	181.5
S ₂	79.5	88.5	120	155.5	155.5	185.5	228	258.5
mass [kg]	0.8	1.6	3.2	9.8	9.8	15.8	29	52

- Ordering code: **SC (TF side)** screw jacks Mod. A
with SC fitted on side towards acme screw attachment
- Ordering code: **SC (opposite TF side)** screw jacks Mod. A
with SC fitted on side opposite to acme screw attachment
- Ordering code: **SC (screw side)** screw jacks Mod. B
with SC fitted on side towards acme screw
- Ordering code: **SC (opposite screw side)** screw jacks Mod. B
with SC fitted on side opposite to acme screw

Screw jacks MA Series - options

Bellows

Available for both screw jacks models: with travelling screw (Mod. A) and with travelling nut (Mod. B). In applications with particular environment conditions, bellows protect the screw from contaminants.

The usually supplied bellows are circular, sewn (double seam), in NYLON with a PVC outside and inside coating. For special application requirements, different executions or materials can be supplied on request.

The bellows cause changes to the retracted and extended lengths and screw jack overall dimensions stated in the catalogue. On request, orders will be acknowledged with a screw jack drawing giving exact dimensions.



Screw jacks MA Mod.A with bellows

Usually, bellows are fitted between the acme screw attachment and worm gear-box, and at the opposite side the protection tube is fitted.

In case the screw jack shall have a screw without attachment, it is recommended to order it with a sketch of the required bellows attachment dimensions.

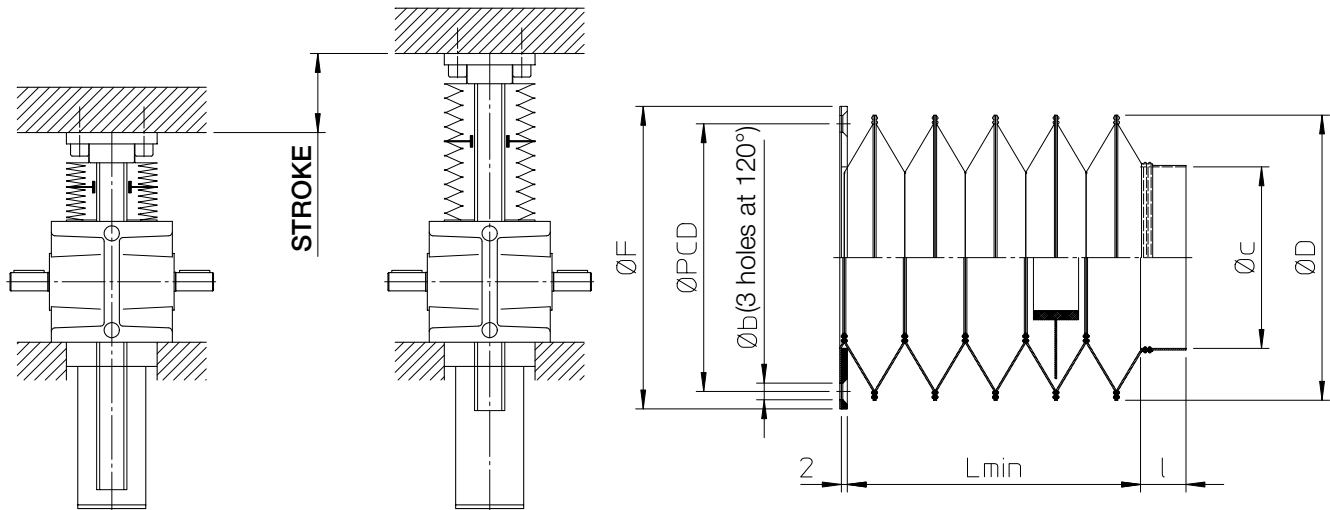

Following table shows the bellows available on stock:

- execution: circular, sewn;
- material: NYLON with a PVC outside and inside coating;
- stroke: 300 mm, 600 mm or 1 000 mm; on request, bellows for different stroke can be supplied;
- dimensions of two attachments suitable for fitting to the screw jack housing and to the flange end P.

	MA 5	MA 10	MA 25	MA 50	MA 100
Ø D	65	80	100	120	120
L _{min} (for C300)	80	40	50	—	—
L _{min} (for C600)	180	90	90	90	90
L _{min} (for C1000)	—	—	144	144	144
Ø c	26	31	41	51	71
l	10	10	20	25	30
Ø F	65	80	100	120	160
Ø PCD	55	68	88.5	107	140
Ø b	4.5	5.5	5.5	6.5	6.5

Ordering code: **B**

Screw jacks MA Series - options

Screw jacks MA Mod.B with bellows

Bellows are normally fitted between the screw jack housing and the nut and also between the nut and the acme screw end. Some applications may require bellows in only one of these two position.

The dimension of the bellows attachment between screw jack housing and bronze nut is determined by the screw jack's dimensions while the bellows attachment between bronze nut and acme screw end depends on the application structure the bellows shall fit.

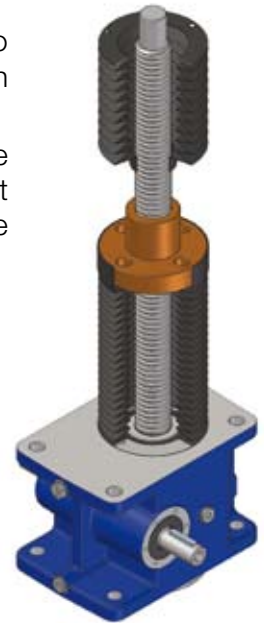

2

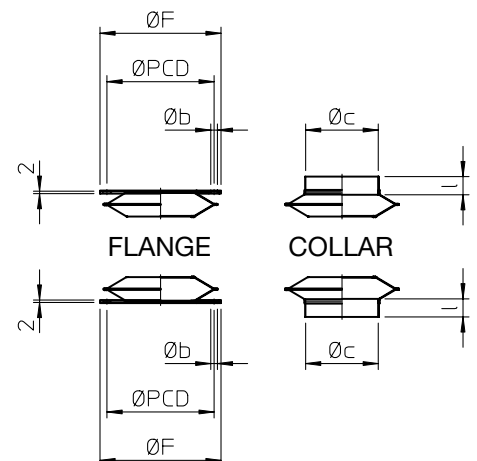
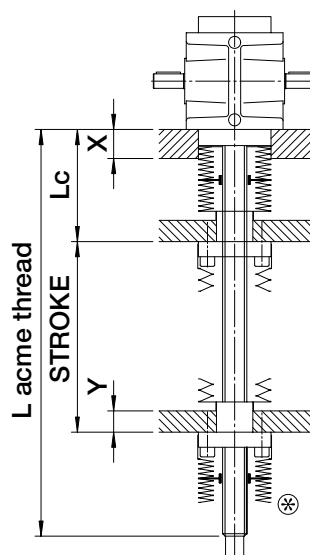
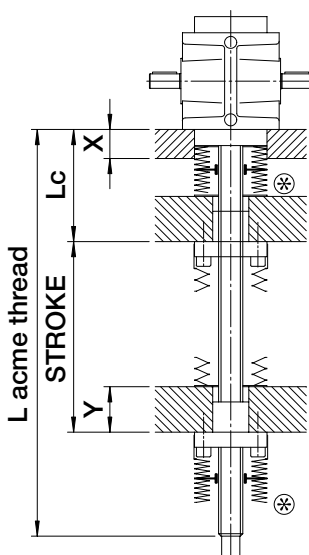
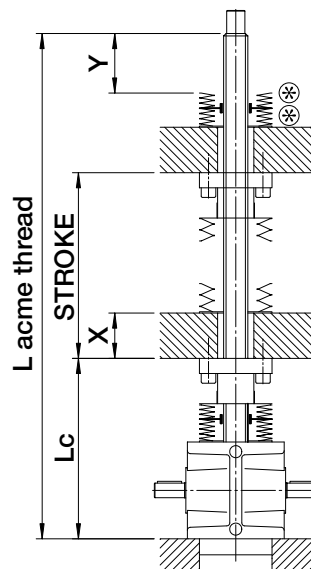
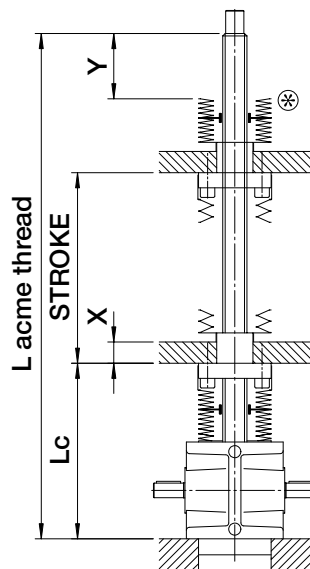
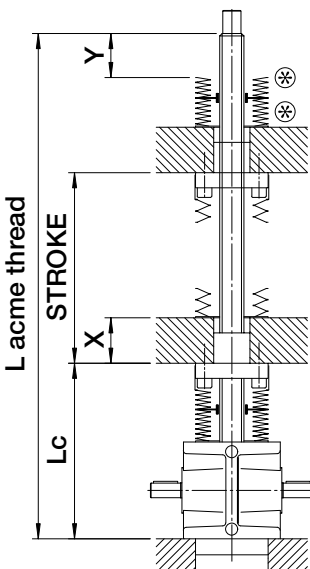
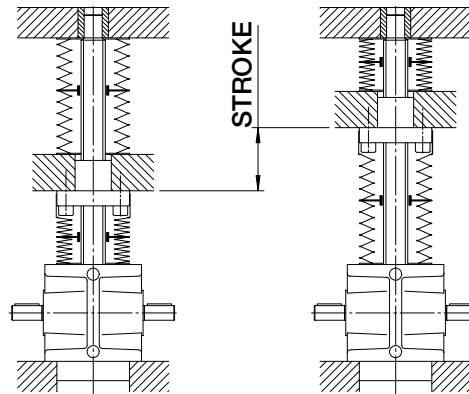

⊗ - bellows attachment dimensions to be defined

Screw jacks MA Series - options

Safety nut

Available for both screw jacks models: with travelling screw (Mod. A) and with travelling nut (Mod. B).

The safety nut is a back-up feature to prevent the load dropping in an uncontrolled manner in the event of working nut thread breaking due to overload or achieving of critical wear level (wear level that causes the breaking of the remaining thread section with normal working load only).

The safety nut is an extension to the standard nut (wormwheel inside Mod.A screw jacks or external travelling nut of Mod.B screw jacks) and changes the screw jack overall dimensions.

The safety nut works with one particular load direction only. Its position as regards the standard nut is conditioned by the load direction.

Following drawings show a screw jack with safety nut in case of acme screw subjected to push load. In case of pull load, the position of the nut would be on the opposite side of the screw jack housing (Mod. A) or of the external travelling nut (Mod. B).

By new screw jacks, the distance **b** between standard nut and safety nut is equal to the half of the profile pitch (**P**) of the acme thread.

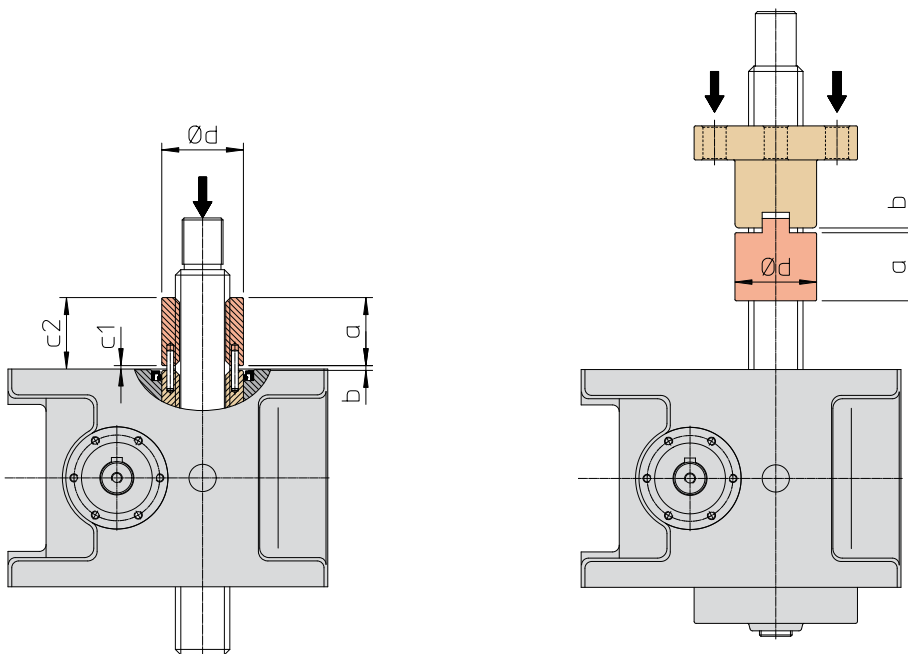

Screw jacks MA Mod.A with safety nut

	MA 5	MA 10	MA 25	MA 50	MA 80	MA 100	MA 200	MA 350
a	28	33	35	50	70	70	95	115
b	2	2.5	3	3.5	4.5	6	6	8
c ₁	1.5	2	2.5	2.5	3.5	5	5	7
c ₂	29.5	35	37.5	52.5	73.5	75	100	122
Ød	30	35	50	60	70	80	100	140

Ordering code: **MSA push** screw jacks Mod.A with safety nut for push load

Ordering code: **MSA pull** screw jacks Mod.A with safety nut for pull load

Screw jacks MA Mod.B with safety nut

	MA 5	MA 10	MA 25	MA 50	MA 80	MA 100	MA 200	MA 350
a	28	33	35	50	70	70	95	115
b	2	2.5	3	3.5	4.5	6	6	8
Ød	30	40	50	60	75	80	100	150

Ordering code: **SBC push** screw jacks Mod.B with safety nut for push load

Ordering code: **SBC pull** screw jacks Mod.B with safety nut for pull load

Screw jacks MA Series - options

Acme thread wear level check

Available for both screw jacks models: with travelling screw (Mod. A) and with travelling nut (Mod. B).

Due to working conditions (load, speed, temperature, lubrication), the thread of the working nut wears out. Some applications require the possibility to keep the current wear level under control to prevent reaching the critical wear level and consequent thread breaking by replacing the nut early.

Usually, a value equal to 1/4 of the profile pitch (**P**) of the acme thread is considered as max. wear level admitted.

With thread wear, the distance **b** between working nut and safety nut (see drawings on previous page) reduces to the working nut. By measuring this change, it is possible to get the current wear level of the thread.

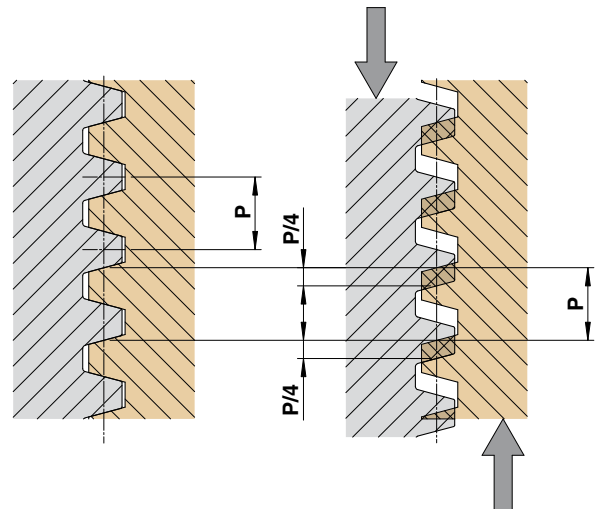

Following drawings show the possible solutions:

- check of dimension **c₁**, **c₂**, **c₃** or **c₄** for screw jacks with travelling screw (Mod. A) or of distance **b** for screw jacks with travelling nut (Mod. B) - see drawings on previous page and below - comparing the current value with the initial one (with new screw jack),
- appliance of an electric switch (see drawings below) which is activated when the pre-established wear level is reached giving an electric signal.

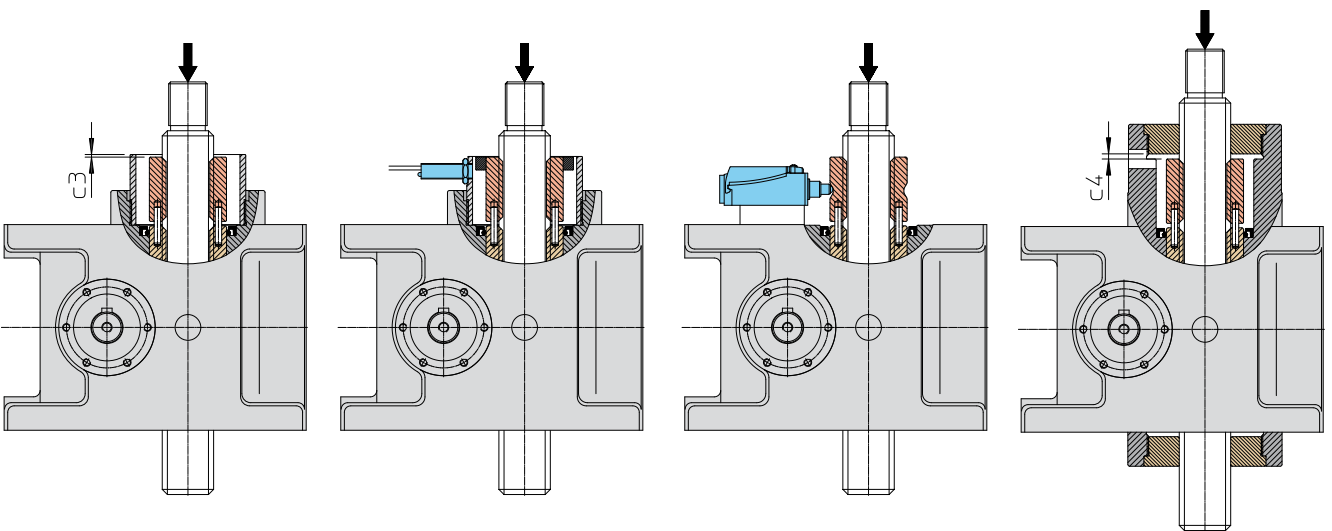

Thread wear control on screw jacks MA Series Mod.A

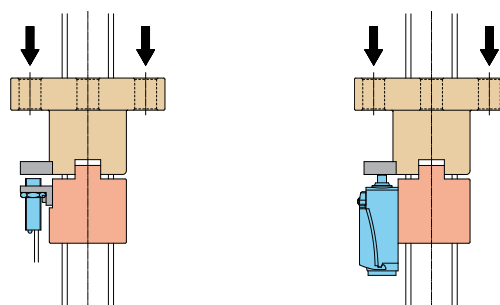

Thread wear control on screw jacks MA Series Mod.B

Screw jacks MA Series - options

Wormwheel rotation detector

Available for both screw jacks models: with travelling screw (Mod. A) and with travelling nut (Mod. B).

Some applications require the possibility to verify if the wormwheel rotates while the worm shaft is moving in order to get information about the good condition and functioning of the wormwheel tootinging.

Functioning on screw jacks with travelling screw (Mod.A): usually, this device is required for applications where a safety nut is already present. A “crown” of empty and full spaces (created by machining the safety nut end, see picture on the right), while rotating, activates a corresponding proximity switch. As output of such proximity switch, activated and deactivated by the alternation of empty and full spaces, a “train” of impulses is generated and it confirms the rotation of the wormwheel. On the contrary, the constant output signal of the proximity means the stop of the wormwheel.

Functioning on screw jacks with travelling nut (Mod. B): on the opposite side of the acme screw, a cylindrical element, machined in order to have a “crown” of empty and full spaces (see picture on the right), is fixed to the wormwheel. While rotating, it activates and deactivates a corresponding proximity switch. As output of such proximity switch, activated and deactivated by the alternation of empty and full spaces, a “train” of impulses is generated and it confirms the rotation of the wormwheel. On the contrary, the constant output signal of the proximity means the stop of the helical wormwheel.

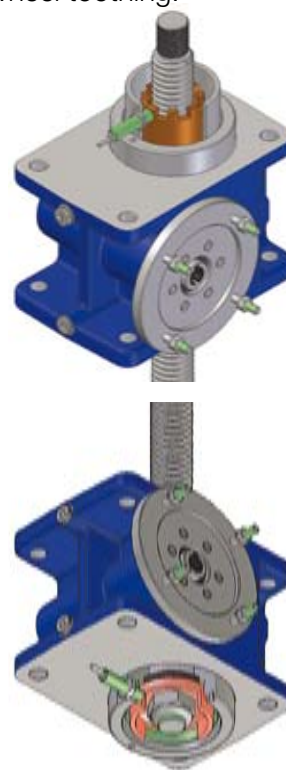

Magnetic stroke end switches

Available for screw jacks with travelling screw (Mod. A) and for size 5, 10 o 25. Not compatible with anti-turn device AR.

Functioning: the magnetic stroke end switches are sensors with reed contact and are fixed with a clamp on the protective tube T, made in aluminium or other non-magnetic metal. They are activated by the magnetic field generated by a magnetic ring fitted on the acme screw end.

In case the screw jack is not stopped after the sensor activation, without magnetic field the sensor restores the original state. In case the limit switches are used to stop the screw jack, we recommend to provide for an electric connection in order to latch the signal and to prevent that the screw jack moves again in the same direction.

Screw jacks with magnetic limit switches are supplied with two sensors for the acme screw extreme positions. On request, extra switches for intermediate distances can be supplied.

The position of the sensors along the tube is adjustable.

Technical details:

Contact:	normally CLOSED (NC)	normally OPEN (NO)
Voltage range:	(3 ... 130) Vdc / (3 ... 130) Vac	
Switching capacity:	20 W / 20 VA	
Max. switching current at 25°C:	300 mA (resistive load)	
Max. inductive load:	3 W (simple coil)	—
Wires:	2 × 0.25 mm ²	
Cable length:	2 m	

Ordering code: **FCM-NC** for screw jacks with normally closed magnetic switches FCM

Ordering code: **FCM-NO** for screw jacks with normally open magnetic switches FCM



Screw jacks MA Series - options

Inductive proximity stroke end switches

Available for screw jacks with travelling screw (Mod.A) only.

Functioning: proximity limit switches are PNP inductive sensors with normally CLOSED contact (NC) fitted on the protective tube and activated by the metallic ring fixed on the acme screw end.

In case the screw jack is not stopped after the sensor activation, when the metallic ring moves away the sensor restores the original state (becomes deactivated). In case the limit switches are used to stop the screw jack, we recommend to provide for an electric connection in order to latch the signal and to prevent that the screw jack moves again in the same direction.

Screw jacks with proximity limit switches are supplied with two sensors for the acme screw extreme positions. Extra switches for intermediate distances available on request.

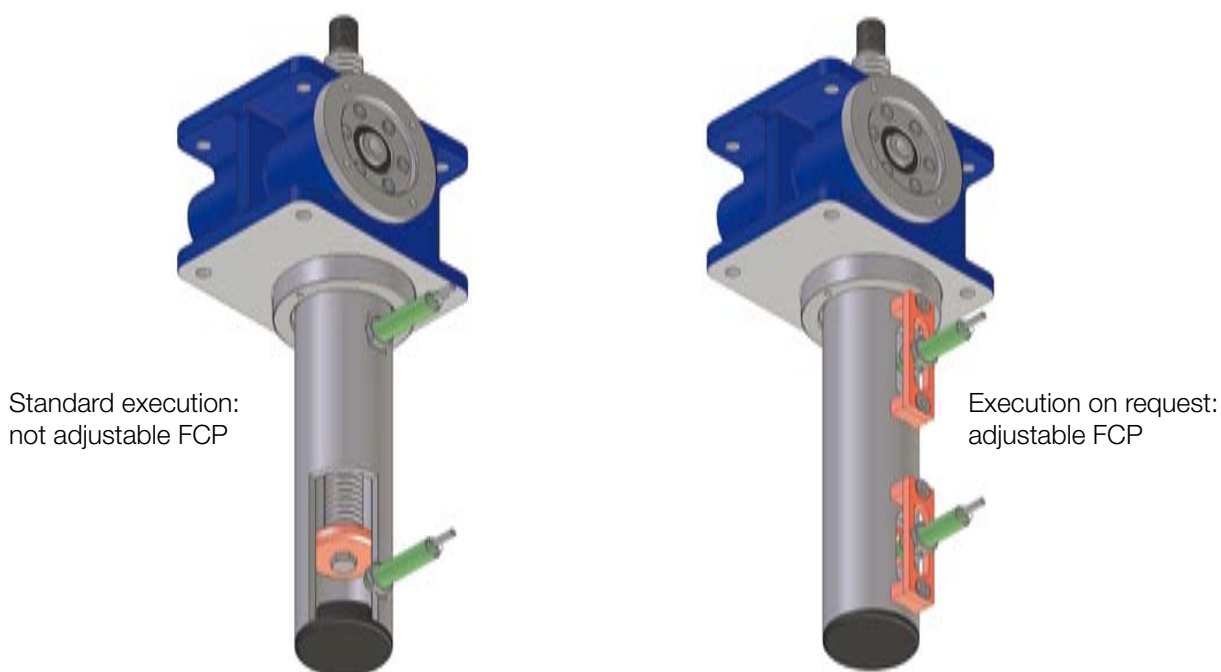

On standard execution, the sensors position along the tube is not adjustable and is not angularly fixed. On request, it can be supplied with angular position at customer's indication.

Execution with axial adjustment of the sensors position available on request.

Technical details:

Type:	inductive, PNP
Contact:	normally CLOSED (NC)
Voltage range:	(10 ... 30) Vdc
Max. output current:	200 mA
Voltage drop (activated sensor):	< 1.8 V
Wires:	2 × 0.2 mm ²
Cable length:	2 m

Ordering code: **standard FCP (not adjustable)**
adjustable FCP

Adjustable backlash

Available for both screw jacks models: with travelling screw (Mod.A) and with travelling nut (Mod.B).

The adjustment of the axial backlash in the acme thread is a feature recommended for applications where load acts in both directions and/or there are vibrations. It can be obtained by using of adjustable backlash device RMG, which reduces axial backlash between acme screw and bronze nut allowing high positioning precision. With the RMG device it is also possible to compensate the wear of the nut thread.

On screw jacks with travelling screw (Mod. A), the working nut (the helical wormwheel inside the housing) is split in two halves (see picture on the right). By screwing the adjustment cover (after the release of the locking screw), the two halves of the wormwheel close in until the axial backlash is set to zero. The thread of one of the two halves of the wormwheel will touch one flank of the acme screw thread, while the thread of the other half will touch the opposite flank.

Both nuts work in a perfectly symmetric way, therefore the load capacity for both push or pull load is the same and is equivalent to the nominal capacity.

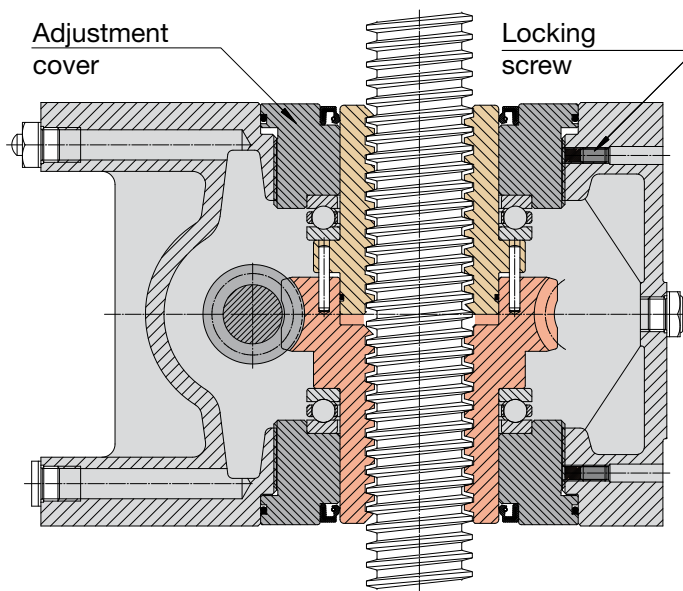

On screw jacks with travelling nut (Mod. B), the RMG device is made by two nuts (main nut and secondary nut, see picture on the right). It allows to adjust the axial backlash, but not to work with maximum load capacity in both directions. We recommend to carefully evaluate the mounting position to make the main nut work in the prevailing load condition.

In any case, please contact SERVOMECH Engineering Dpt. for proper and suitable evaluations.

By screwing the adjustment screws the two nuts close in and, as a consequence, the acme thread of one of the two nuts will near one side of the acme screw thread, while the thread of the other will near the opposite side of the acme screw. In this way the axial backlash will be reduced as required.

The torque transmission from the second nut to the main nut is given by the front clutch between the two nuts.

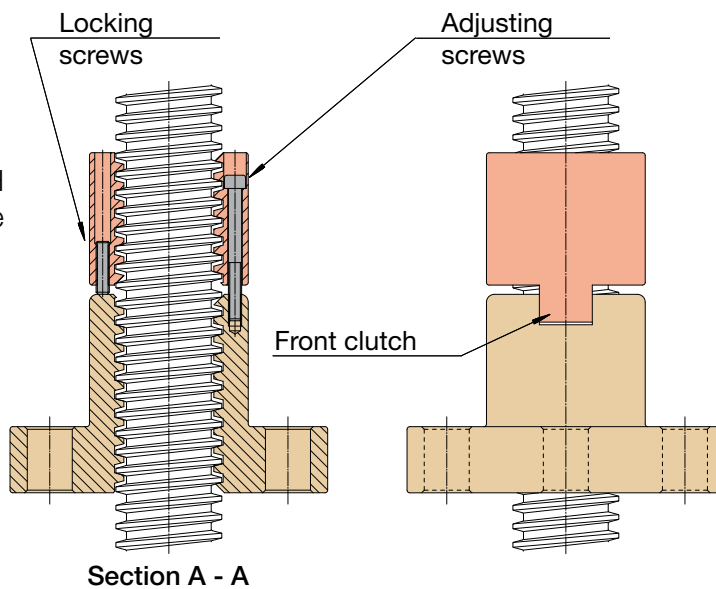

An excessive backlash reduction can reduce screw jack efficiency. For further details, please contact SERVOMECH Engineering Dpt.

Codice: **RMG**

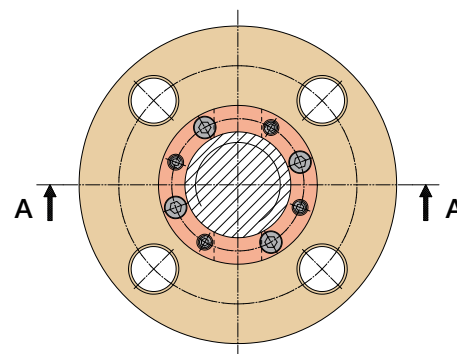

Screw jacks MA Series - options

Material: stainless steel

For applications in particular environment conditions or in food industry, the screw jacks MA Series can be supplied with stainless steel acme screw and/or screw attachment on request. Available steels: AISI 303, AISI 304, AISI 316.

Ordering code: **TR inox** stainless steel acme screw for screw jacks Mod. A or Mod. B

Ordering code: **P inox** stainless steel flange end P, for screw jacks Mod. A

Ordering code: **TF inox** stainless steel rod end TF, for screw jacks Mod. A

IEC Motor connection

		MA 5	MA 10	MA 25	MA 50	MA 80	MA 100	MA 200	MA 350
63	B5	F	F	F					
	B14	F	F						
71	B5	B	B	F	F	F			
	B14	B	B	F					
80	B5			B	F	F	F		
	B14			B					
90	B5			B	B	B	F	F	
	B14			B	B	B			
100 - 112	B5				B	B	B	F	
	B14				B	B	B		
132	B5							B	B
160	B5								B

F - plug-in IEC flange and hollow shaft

B - bell-housing + coupling IEC

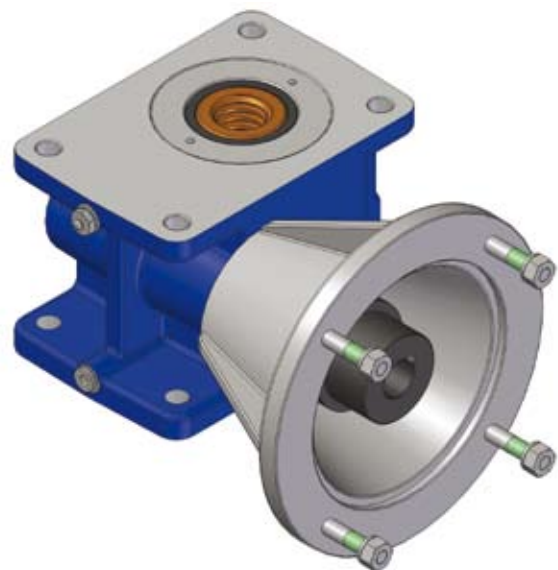
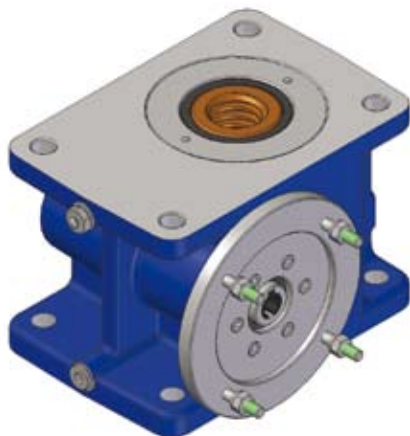

Flange or bell-housing at drawing for hydraulic motors or servomotors connection available on request.

Screw jacks MA Series - coding description

Screw jacks MA Series with travelling screw (Mod.A)

MA	50	Mod.A	RL1	Vers. 3 (80 B5)	U-RH	C300							
1	2	3	4	5	6	7							
TF	B	G	CA	MSA	/	RMG	/	CA	G	SC	T	AR	FCP
8													
...													
9													
...													
10													
AC 3-phase brake motor 0.75 kW 4 poles 230/400 V 50 Hz IP 55 Isol. F													
11													

1 MA (screw jack MA Series)

2 Screw jack size

5 ... 350

page 20 - 21, 24 - 25, 28, 31

3 Mod.A (Model: travelling screw)

4 Ratio and number of acme screw starts

page 20 - 21, 24 - 25, 28, 31

5 Input versions

Vers.1, Vers.2, Vers.3, Vers.4, Vers.5, Vers.6

page 7

6 Screw jack mounting and input shaft position

U-RH, U-LH, D-RH, D-LH, H-RH, H-LH

page 7

7 Screw jack stroke length (ex.: C300 = 300 mm stroke)

8 Options

NF, P, TF, N	Screw end	page 34 - 35
B	Bellows	page 40
SC	Trunnion mount	page 39
G	Bronze guide	page 37
CB, CA	Low cover, raised cover	page 37
RMG	Adjustable backlash	page 46
SN	Stop nut	page 38
T	Protective tube	page 38
AR	Anti-turn device	page 38
FCM-NC	Magnetic stroke end switches (normally closed)	page 44
FCP-NC	Proximity stroke end switches (PNP, normally closed)	page 45

9 Other options

example: encoder (with all relevant data)

10 Further specifications

example: stainless steel acme screw AISI 303
example: low temperature lubricant

11 Motor specifications

12 Coding form

page 49

13 Application sketch

Screw jacks MA Series - coding description

Screw jacks MA Series with travelling screw (Mod.A)

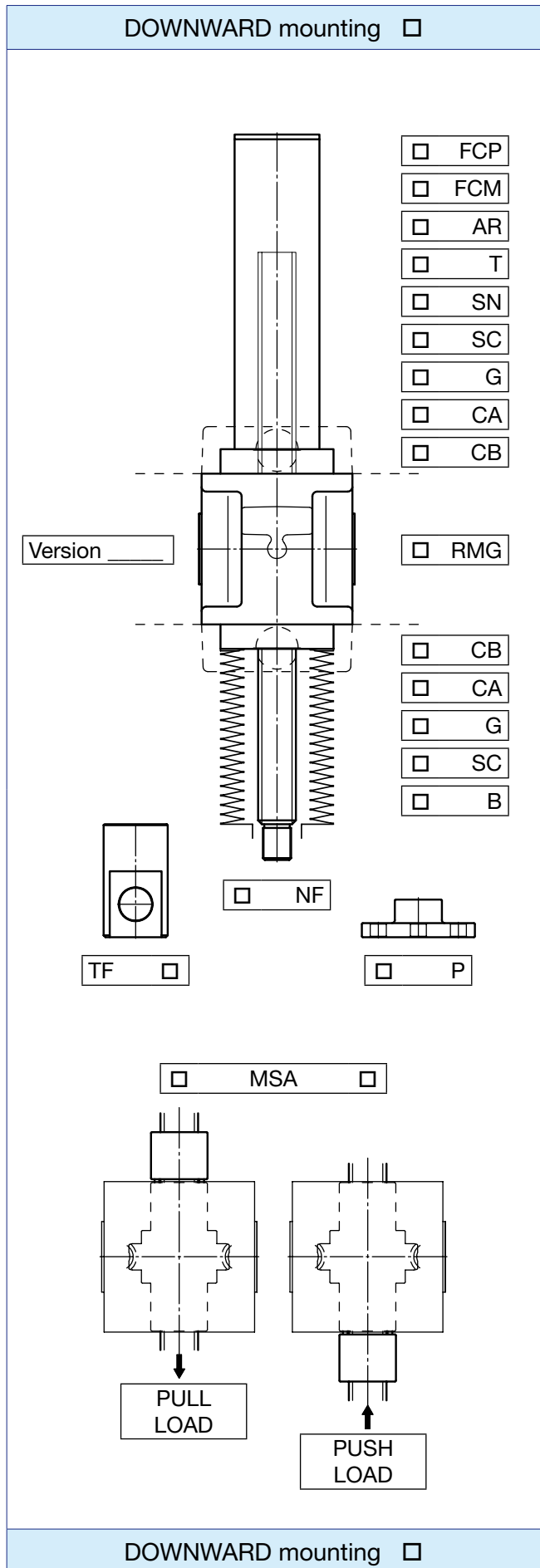
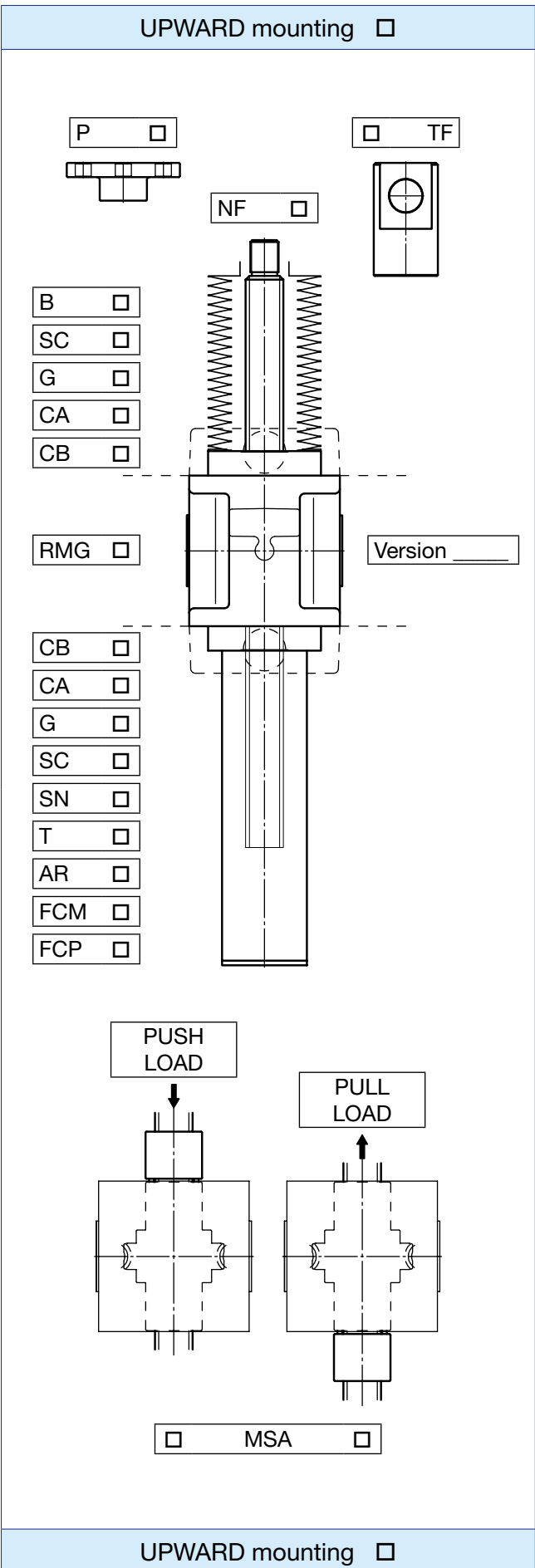

2

Screw jacks MA Series - coding description

Screw jacks MA Series with travelling nut (Mod.B)

MA	50	Mod.B	RL1	Vers. 3 (80 B5)	U-RH	C300
1	2	3	4	5	6	7
N	B2	MB+SBC	B1	CB	/	CA
8						
...						
9						
...						
10						
AC 3-phase brake motor 0.75 kW 4 poles 230/400 V 50 Hz IP 55 Isol. F						
11						

1 MA (screw jack MA Series)

2 Screw jack size

5 ... 350

page 20 - 21, 24 - 25, 28, 31

3 Mod.B (Model: travelling nut)

4 Ratio and number of acme screw starts

page 20 - 21, 24 - 25, 28, 31

5 Input versions

Vers.1, Vers.2, Vers.3, Vers.4, Vers.5, Vers.6

page 7

6 Screw jack mounting and input shaft position

U-RH, U-LH, D-RH, D-LH, H-RH, H-LH

page 7

7 Screw jack stroke length (ex.: C300 = 300 mm stroke)

8 Options

N Screw end

page 34 - 35

B₁, B₂ Bellows

page 41

MB Working nut

page 34 - 35

SBC Safety nut

page 42

RMG Adjustable backlash

page 46

CB, CA Low cover, raised cover

page 37

9 Other options

example: encoder (with all relevant data)

10 Further specifications

example: stainless steel acme screw AISI 303

example: low temperature lubricant

11 Motor specifications

12 Coding form

page 51

13 Application sketch

Screw jacks MA Series - coding description

Screw jacks MA Series with travelling nut (Mod.B)

UPWARD mounting

RMG

MB+SBC MB MB+SBC

MB MB+SBC

PULL LOAD

PUSH LOAD

MB+SBC MB MB+SBC

MB+SBC MB MB+SBC

N

B2

B1

CA

CB

Version _____

CB

CA

UPWARD mounting

DOWNWARD mounting

CA

CB

Version _____

CB

CA

B1

B2

N

MB+SBC MB MB+SBC

MB+SBC MB MB+SBC

PUSH LOAD

PULL LOAD

MB+SBC MB MB+SBC

MB+SBC MB MB+SBC

RMG

DOWNWARD mounting

Screw jacks MA Series

Screw jacks MA Series with travelling screw (Mod. A) - spare parts

2

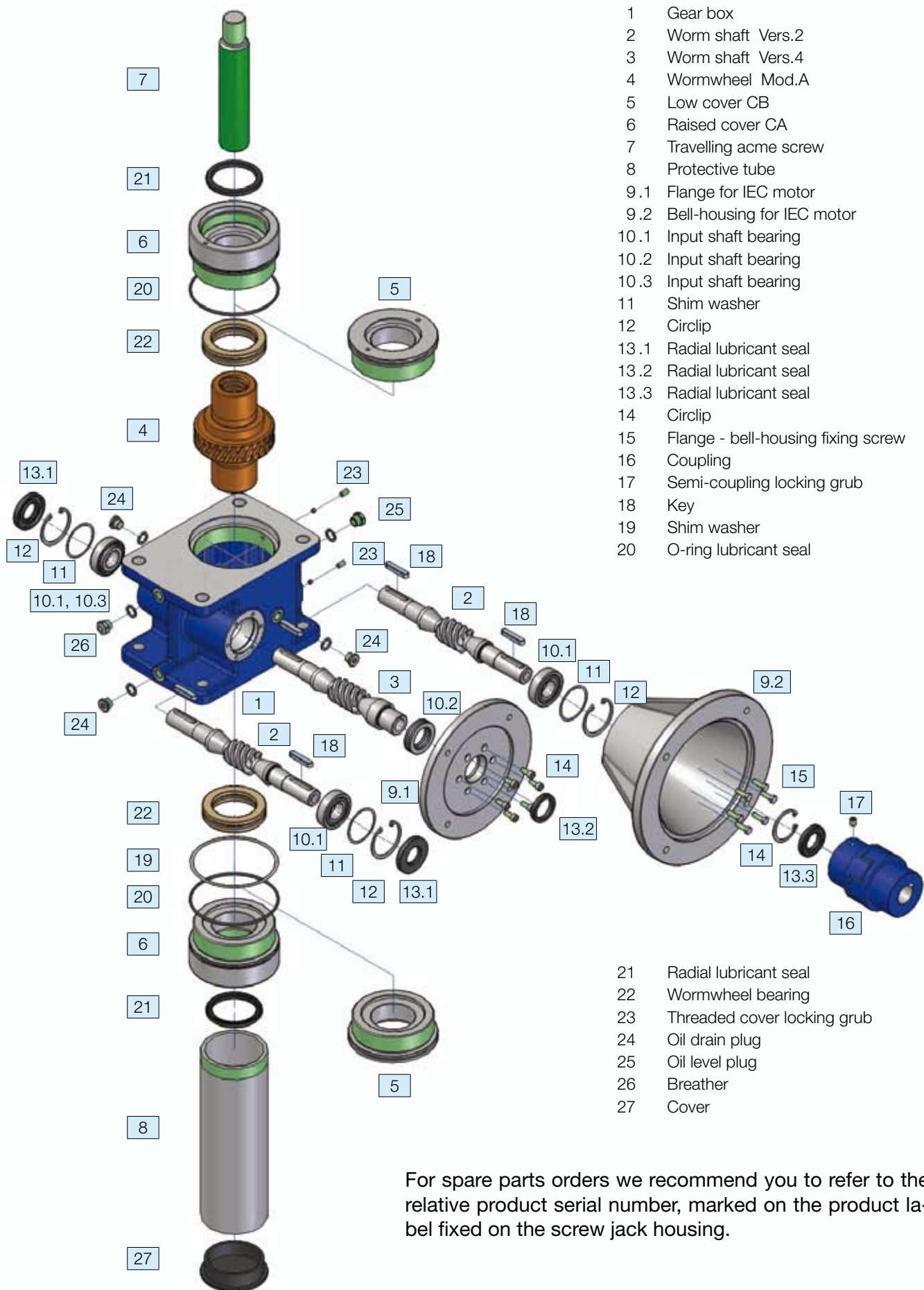

For spare parts orders we recommend you to refer to the relative product serial number, marked on the product label fixed on the screw jack housing.

Screw jacks MA Series

Screw jacks MA Series with travelling nut (Mod. B) - spare parts

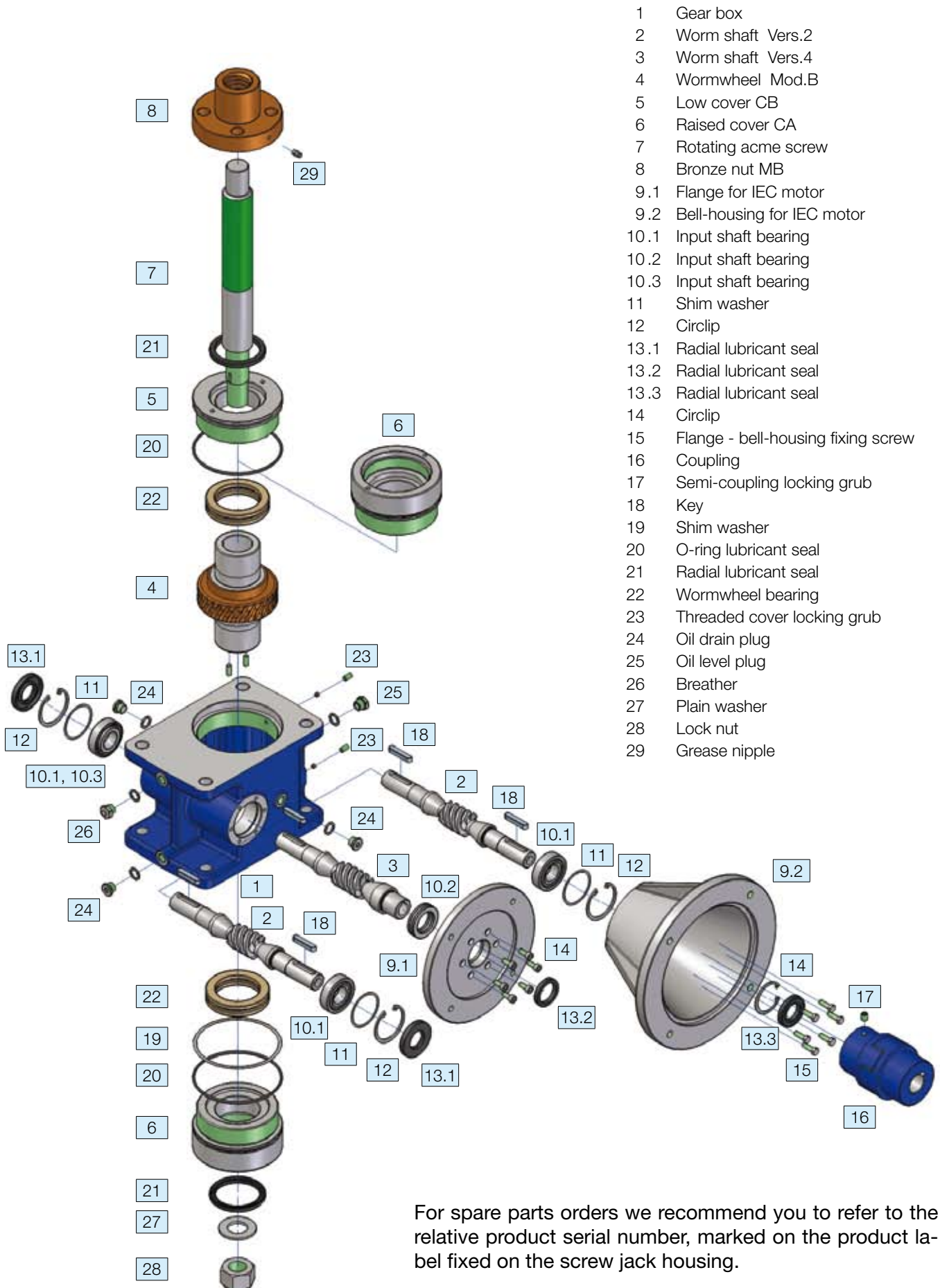

- 1 Gear box
- 2 Worm shaft Vers.2
- 3 Worm shaft Vers.4
- 4 Wormwheel Mod.B
- 5 Low cover CB
- 6 Raised cover CA
- 7 Rotating acme screw
- 8 Bronze nut MB
- 9.1 Flange for IEC motor
- 9.2 Bell-housing for IEC motor
- 10.1 Input shaft bearing
- 10.2 Input shaft bearing
- 10.3 Input shaft bearing
- 11 Shim washer
- 12 Circlip
- 13.1 Radial lubricant seal
- 13.2 Radial lubricant seal
- 13.3 Radial lubricant seal
- 14 Circlip
- 15 Flange - bell-housing fixing screw
- 16 Coupling
- 17 Semi-coupling locking grub
- 18 Key
- 19 Shim washer
- 20 O-ring lubricant seal
- 21 Radial lubricant seal
- 22 Wormwheel bearing
- 23 Threaded cover locking grub
- 24 Oil drain plug
- 25 Oil level plug
- 26 Breather
- 27 Plain washer
- 28 Lock nut
- 29 Grease nipple

For spare parts orders we recommend you to refer to the relative product serial number, marked on the product label fixed on the screw jack housing.

Screw jacks SJ Series

Screw jacks SJ Series with travelling screw (Mod.A) STRUCTURAL ELEMENTS

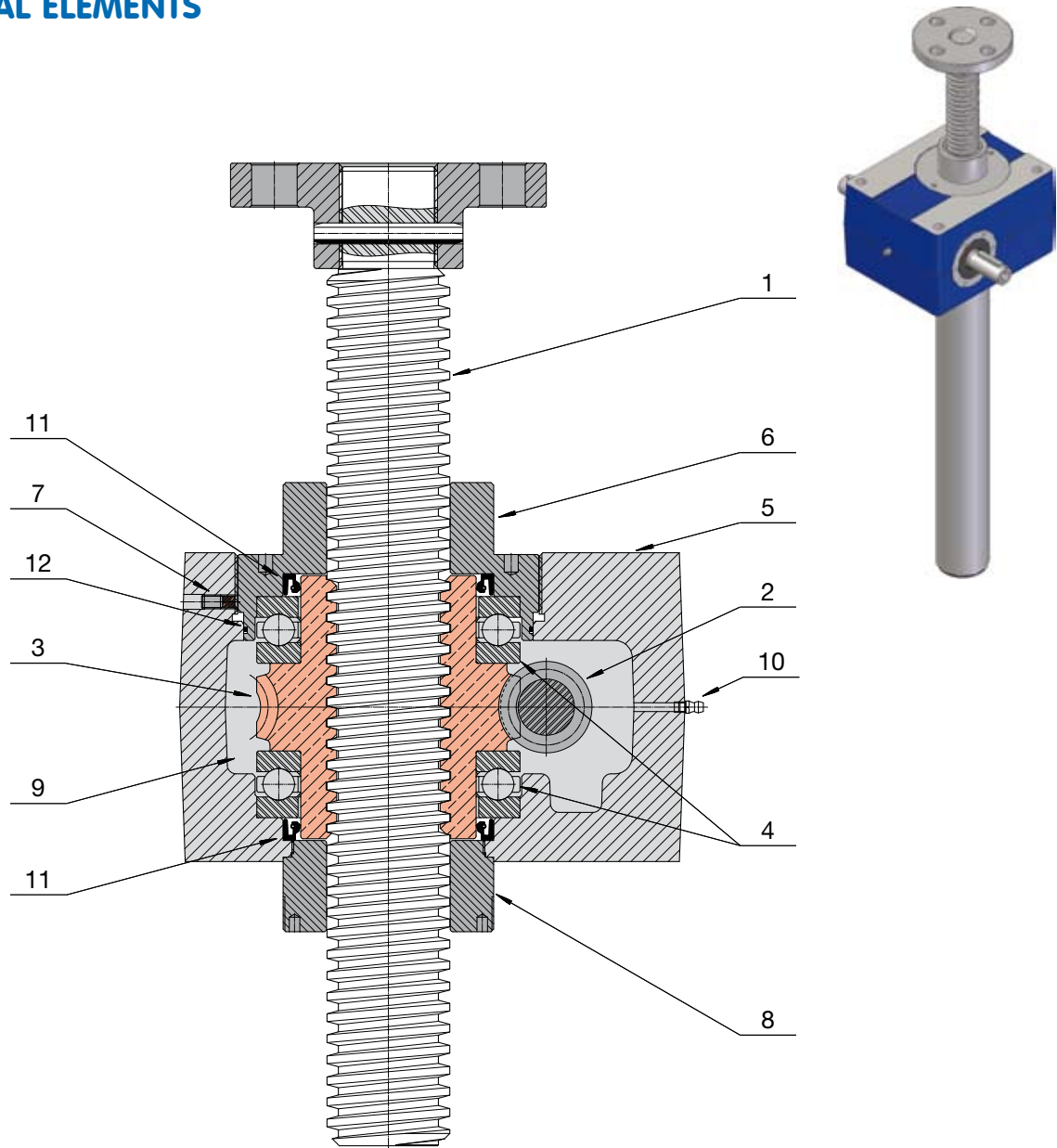

- 1 - acme screw in steel C 43 (UNI 7847), rolled or whirled thread
- 2 - worm shaft with true involute, ground worm profile ZI (UNI 4760), made in steel, case-hardened
- 3 - bronze wormwheel with internal nut, toothing with true involute profile ZI (UNI 4760)
- 4 - thrust ball bearing for high load capacity
- 5 - monoblock gear box
- 6 - threaded cover with guide for acme screw; may be used as a spigot diameter
- 7 - grub screw which prevents the threaded cover unscrewing
- 8 - guide for acme screw; may be used as a spigot diameter
- 9 - long-life synthetic grease lubricated worm gearbox
- 10 - grease nipple
- 11 - radial lubricant seal
- 12 - O-Ring as lubricant seal

Screw jacks SJ Series

Screw jacks SJ Series with travelling nut (Mod.B) STRUCTURAL ELEMENTS

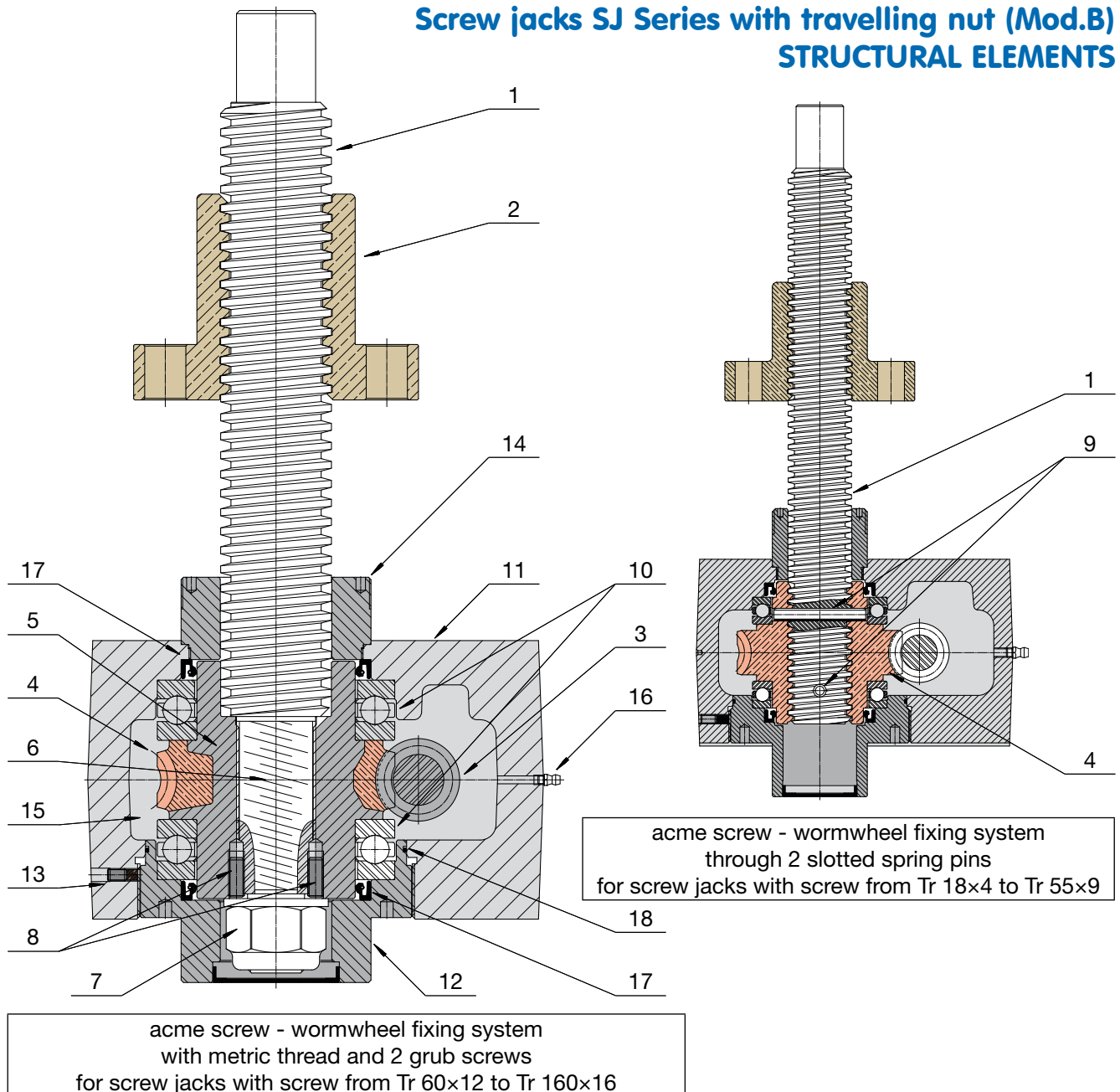

acme screw - wormwheel fixing system
through 2 slotted spring pins
for screw jacks with screw from Tr 18x4 to Tr 55x9

acme screw - wormwheel fixing system
with metric thread and 2 grub screws
for screw jacks with screw from Tr 60x12 to Tr 160x16

- 1 - acme screw in steel C 43 (UNI 7847), whirled thread
- 2 - bronze travelling nut with flange
- 3 - worm shaft with true involute, ground worm profile ZI (UNI 4760), made in steel, case-hardened
- 4 - bronze wormwheel with true involute profile ZI (UNI 4760)
- 5 - cast iron support of the wormwheel bronze rim
- 6 - acme screw fixed to the wormwheel through LEFT-HAND (for push load) or RIGHT-HAND (for pull load) metric thread
- 7 - lock nut with the opposite direction metric thread to ensure safe acme screw fixing
- 8 - acme screw – wormwheel pins against unscrewing
- 9 - slotted spring pin
- 10 - thrust ball bearing for high load capacity
- 11 - monoblock gear box
- 12 - threaded cover with guide for acme screw; may be used as a spigot diameter
- 13 - grub screw which prevents the threaded cover unscrewing
- 14 - guide for acme screw; may be used as a spigot diameter
- 15 - long-life synthetic grease lubricated worm gearbox
- 16 - grease nipple
- 17 - radial lubricant seal
- 18 - O-Ring as lubricant seal

Screw jacks SJ Series

Screw jacks SJ Series with 1-start acme screw TECHNICAL SPECIFICATIONS

SCREW JACK SIZE		SJ 5	SJ 10	SJ 25	SJ 50	SJ 100	SJ 150	SJ 200	
Load capacity [kN], (push - pull)		5	10	25	50	100	150	200	
1-start acme screw		Tr 18x4	Tr 22x5	Tr 30x6	Tr 40x7	Tr 55x9	Tr 60x12	Tr 70x12	
Worm gear centre distance [mm]		25	30	50	63	63	80	90	
Available ratio	RH	1 : 4 (5 : 20)	—	—	—	—	—	—	
	RV	1 : 6.25(4 : 25)	1 : 4 (4 : 16)	1 : 6 (4 : 24)	1 : 7 (4 : 28)	1 : 7 (4 : 28)	1 : 8 (4 : 32)	1 : 7 (4 : 28)	
	RN	1 : 12.5(2 : 25)	1 : 16 (2 : 32)	1 : 18 (2 : 36)	1 : 14 (2 : 28)	1 : 14 (2 : 28)	1 : 24	—	
	RL	1 : 25	1 : 24	1 : 24	1 : 28	1 : 28	1 : 32	1 : 28	
Stroke [mm] for 1 input shaft revolution	Ratio	RH1	1	—	—	—	—	—	
		RV1	0.64	1.25	1	1	1.28	1.5	1.71
		RN1	0.32	0.31	0.33	0.5	0.64	0.5	—
		RL1	0.16	0.21	0.25	0.25	0.32	0.375	0.43
Starting efficiency	Ratio	RH1	0.25	—	—	—	—	—	
		RV1	0.25	0.26	0.20	0.18	0.20	0.20	0.19
		RN1	0.21	0.20	0.16	0.15	0.17	0.13	—
		RL1	0.16	0.16	0.13	0.11	0.13	0.12	0.12
Running efficiency at 1500 rpm ⁽¹⁾	Ratio	RH1	0.35	—	—	—	—	—	
		RV1	0.34	0.36	0.34	0.32	0.33	0.36	0.36
		RN1	0.29	0.28	0.27	0.28	0.29	0.29	—
		RL1	0.25	0.25	0.25	0.23	0.24	0.26	0.25
Starting torque on input shaft at max. load [Nm]	Ratio	RH1	3.8	—	—	—	—	—	
		RV1	2.5	9	20	44	77	120	325
		RN1	1.7	3.5	8.3	25	47	62	—
		RL1	1	2.5	7.6	18	34	50	125
Max. permissible operating power [kW] ⁽²⁾	Ratio	RH1	0.40	—	—	—	—	—	
		RV1	0.40	0.60	1.2	2.4	2.5	3	4
		RN1	0.20	0.30	0.7	1.7	1.8	2.6	—
		RL1	0.17	0.25	0.6	1.2	1.2	2.3	3.2
Reactive torque on acme screw (nut) required at max. load [Nm]		8	20	65	165	460	800	1 200	
Gear box material		casting in aluminium alloy EN 1706 - AC-AISi10Mg T6			casting in cast iron EN-GJL-250 (UNI EN 1561)				
Mass of screw jack without acme screw [kg]		1.5	2.3	10.4	25	35	55	75	
Mass for every 100 mm of acme screw [kg]		0.16	0.23	0.45	0.8	1.6	1.8	2.5	

⁽¹⁾ - efficiency figures at different input speed on page 61

⁽²⁾ - THERMAL limit, referred to work with max. duty cycle 30 % over 10 min time period (20 % over 1 hour time period) at 25°C environment temperature

Screw jacks SJ Series

Screw jacks SJ Series with 1-start acme screw TECHNICAL SPECIFICATIONS

SJ 250	SJ 300	SJ 350	SJ 400	SJ 600	SJ 800	SJ 1000	SCREW JACK SIZE	
250	300	350	400	600	800	1000	Load capacity [kN], (push - pull)	
Tr 80×12	Tr 90×12	Tr 100×12	Tr 100×12	Tr 120×14	Tr 140×14	Tr 160×16	1-start acme screw	
90	110	110	140	140	200	200	Worm gear centre distance [mm]	
—	—	—	—	—	—	—	RH	
1 : 7 (4 : 28)	3 : 29	3 : 29	3 : 28	3 : 28	3 : 35	3 : 35	RV	
—	—	—	—	—	—	—	RN	
1 : 28	1 : 30	1 : 30	1 : 29	1 : 29	1 : 36	1 : 36	RL	
—	—	—	—	—	—	—	RH1	
1.71	1.24	1.24	1.29	1.5	1.2	1.37	RV1	
—	—	—	—	—	—	—	RN1	
0.43	0.4	0.4	0.41	0.48	0.39	0.44	RL1	
—	—	—	—	—	—	—	RH1	
0.17	0.15	0.13	0.13	0.13	0.12	0.11	RV1	
—	—	—	—	—	—	—	RN1	
0.11	0.09	0.09	0.08	0.08	0.08	0.07	RL1	
—	—	—	—	—	—	—	RH1	
0.35	0.31	0.29	0.30	0.31	0.28	0.28	RV1	
—	—	—	—	—	—	—	RN1	
0.24	0.22	0.21	0.21	0.21	0.21	0.19	RL1	
—	—	—	—	—	—	—	RH1	
360	350	450	540	960	1175	1675	RV1	
—	—	—	—	—	—	—	RN1	
138	175	225	270	485	605	860	RL1	
—	—	—	—	—	—	—	RH1	
4	8	8	15	17	20	25	RV1	
—	—	—	—	—	—	—	RN1	
3.2	6.5	6.5	12	14	17	22	RL1	
1 650	2 150	2 700	3 100	5 500	8 500	12 000	Reactive torque on acme screw (nut) required at max. load [Nm]	
casting in cast iron EN-GJL-250 (UNI EN 1561)			casting in steel Fe G 60 (UNI 4010)				Gear box material	
75	120	120	260	260	800	800	Mass of screw jack without acme screw [kg]	
3.4	4.4	5.5	5.5	7.9	10.9	14.2	Mass for every 100 mm of acme screw [kg]	

(¹) - efficiency figures at different input speed on page 61

(²) - THERMAL limit, referred to work with max. duty cycle 30 % over 10 min time period (20 % over 1 hour time period)
at 25°C environment temperature

Screw jacks SJ Series - 1-start acme screw

Following tables show the screw jack LINEAR SPEED v [mm/s] and relative TORQUE T_1 [Nm] and POWER P_1 [kW] on input shaft, with reference to the INPUT SPEED n_1 [rpm], the RATIO (RV, RN, RL) and the LOAD [kN] applied on the screw jack.

Intermediate values for linear speed v , torque T_1 and power P_1 at different input speed can be calculated by linear interpolation of the figures stated in the table.

The figures in the tables refer to work with max. duty cycle of 30 % over 10 min time period or 20 % over 1 hour time period at 25°C environment temperature.

ATTENTION! The figures in the **red shaded area** indicate operational restrictions due to thermal limits. When the selection is made within such area, the duty cycle must be reduced or the greater size screw jack must be selected, in order to allow effective heat dissipation. For a better evaluation, please contact SERVOMECH Engineering Dpt.

SJ 5					LOAD																							
n_1 [rpm]	LINEAR SPEED v [mm/s]				5 kN								3 kN								1 kN							
					RATIO				RATIO				RATIO				RATIO											
	RH1	RV1	RN1	RL1	RH1	RV1	RN1	RL1	RH1	RV1	RN1	RL1	RH1	RV1	RN1	RL1	RH1	RV1	RN1	RL1	RH1	RV1	RN1	RL1				
	T_1 Nm	P_1 kW	T_1 Nm	P_1 kW	T_1 Nm	P_1 kW	T_1 Nm	P_1 kW	T_1 Nm	P_1 kW	T_1 Nm	P_1 kW	T_1 Nm	P_1 kW	T_1 Nm	P_1 kW	T_1 Nm	P_1 kW	T_1 Nm	P_1 kW	T_1 Nm	P_1 kW	T_1 Nm	P_1 kW				
1500	25	16	8	4	1.9	0.29	1.3	0.20	0.7	0.12	0.5	0.07	1.1	0.17	0.8	0.12	0.4	0.07	0.3	0.04	0.4	0.06	0.3	0.04	0.1	0.02	0.1	0.01
1000	16.7	10.7	5.3	2.7	2.0	0.21	1.4	0.14	0.8	0.09	0.5	0.05	1.2	0.12	0.8	0.09	0.5	0.05	0.3	0.03	0.4	0.04	0.3	0.03	0.2	0.02	0.1	0.01
750	12.5	8	4	2	2.1	0.16	1.4	0.11	0.8	0.07	0.5	0.04	1.3	0.10	0.8	0.07	0.5	0.04	0.3	0.03	0.4	0.03	0.3	0.02	0.2	0.01	0.1	0.01
500	8.3	5.3	2.7	1.3	2.3	0.12	1.5	0.08	0.9	0.05	0.6	0.03	1.4	0.07	0.9	0.05	0.5	0.03	0.3	0.02	0.5	0.02	0.3	0.02	0.2	0.01	0.1	0.01
300	5	3.2	1.6	0.8	2.4	0.08	1.6	0.05	1.0	0.03	0.6	0.02	1.5	0.05	1.0	0.03	0.6	0.02	0.4	0.01	0.5	0.02	0.3	0.01	0.2	0.01	0.1	0.01
100	1.7	1.1	0.5	0.3	2.8	0.03	2.0	0.02	1.1	0.01	0.7	0.01	1.7	0.02	1.2	0.01	0.7	0.01	0.4	0.01	0.6	0.01	0.4	0.01	0.2	0.01	0.1	0.01
50	0.8	0.5	0.3	0.1	3.1	0.02	2.0	0.01	1.2	0.01	0.7	0.01	1.8	0.01	1.2	0.01	0.7	0.01	0.4	0.01	0.6	0.01	0.4	0.01	0.2	0.01	0.1	0.01

SJ 10					LOAD																															
n_1 [rpm]	LINEAR SPEED v [mm/s]				10 kN								8 kN								6 kN								2 kN							
					RATIO				RATIO				RATIO				RATIO																			
	RV1	RN1	RL1	RV1	RN1	RL1	RV1	RN1	RL1	RV1	RN1	RL1	RV1	RN1	RL1	RV1	RN1	RL1	RV1	RN1	RL1	RV1	RN1	RL1	RV1	RN1	RL1									
	T_1 Nm	P_1 kW	T_1 Nm	P_1 kW	T_1 Nm	P_1 kW	T_1 Nm	P_1 kW	T_1 Nm	P_1 kW	T_1 Nm	P_1 kW	T_1 Nm	P_1 kW	T_1 Nm	P_1 kW	T_1 Nm	P_1 kW	T_1 Nm	P_1 kW	T_1 Nm	P_1 kW	T_1 Nm	P_1 kW	T_1 Nm	P_1 kW	T_1 Nm	P_1 kW								
1500	31.3	7.8	5.2	5.6	0.87	1.8	0.28	1.3	0.21	4.4	0.70	1.4	0.22	1.1	0.17	3.3	0.52	1.1	0.17	0.8	0.13	1.1	0.17	0.4	0.06	0.3	0.04									
1000	20.8	5.2	3.5	5.8	0.63	1.8	0.19	1.4	0.15	4.7	0.49	1.5	0.15	1.1	0.12	3.5	0.37	1.1	0.12	0.8	0.09	1.2	0.12	0.4	0.04	0.3	0.03									
750	15.6	3.9	2.6	6.0	0.47	1.9	0.15	1.5	0.11	4.8	0.38	1.5	0.12	1.2	0.09	3.6	0.28	1.2	0.09	0.9	0.07	1.2	0.10	0.4	0.03	0.3	0.02									
500	10.4	2.6	1.7	6.4	0.34	2.0	0.11	1.6	0.08	5.1	0.27	1.6	0.08	1.3	0.07	3.9	0.20	1.2	0.06	1.0	0.05	1.3	0.07	0.4	0.02	0.3	0.02									
300	6.3	1.6	1.1	6.6	0.21	2.1	0.07	1.7	0.05	5.3	0.17	1.7	0.05	1.3	0.04	4.0	0.13	1.3	0.04	1.0	0.03	1.3	0.04	0.4	0.01	0.3	0.01									
100	2.1	0.5	0.4	7.1	0.08	2.3	0.02	2.0	0.02	5.7	0.06	1.8	0.02	1.6	0.02	4.3	0.05	1.4	0.02	1.2	0.01	1.4	0.02	0.5	0.01	0.4	0.01									
50	1.1	0.3	0.2	7.4	0.04	2.5	0.01	2.1	0.01	5.9	0.03	2.0	0.01	1.7	0.01	4.4	0.02	1.5	0.01	1.3	0.01	1.5	0.01	0.5	0.01	0.2	0.01									

SJ 25					LOAD																															
n_1 [rpm]	LINEAR SPEED v [mm/s]				25 kN								20 kN								15 kN								10 kN							
					RATIO				RATIO				RATIO				RATIO																			
	RV1	RN1	RL1	RV1	RN1	RL1	RV1	RN1	RL1	RV1	RN1	RL1	RV1	RN1	RL1	RV1	RN1	RL1	RV1	RN1	RL1	RV1	RN1	RL1	RV1	RN1	RL1									
	T_1 Nm	P_1 kW	T_1 Nm	P_1 kW	T_1 Nm	P_1 kW	T_1 Nm	P_1 kW	T_1 Nm	P_1 kW	T_1 Nm	P_1 kW	T_1 Nm	P_1 kW	T_1 Nm	P_1 kW	T_1 Nm	P_1 kW	T_1 Nm	P_1 kW	T_1 Nm	P_1 kW	T_1 Nm	P_1 kW	T_1 Nm	P_1 kW	T_1 Nm	P_1 kW								
1500	25	8.3	6.3	11.7	1.83	4.8	0.76	3.9	0.61	9.3	1.47	3.9	0.60	3.1	0.49	7.0	1.10	2.9	0.45	2.3	0.37	4.6	0.74	1.9	0.30	1.6	0.25									
1000	16.7	5.6	4.2	12.2	1.28	5.0	0.53	4.1	0.43	9.8	1.03	4.0	0.42	3.3	0.34	7.3	0.77	3.0	0.32	2.5	0.26	4.8	0.52	2.0	0.21	1.6	0.18									
750	12.5	4.2	3.1	12.7	1.00	5.2	0.41	4.2	0.33	10.2	0.80	4.2	0.33	3.4	0.27	7.6	0.60	3.1	0.24	2.5	0.20	5.0	0.40	2.1	0.16	1.7	0.14									
500	8.3	2.8	2.1	13.5	0.71	5.5	0.29	4.5	0.24	10.8	0.56	4.4	0.23	3.6	0.19	8.1	0.42	3.3	0.17	2.7	0.14	5.4	0.28	2.2	0.12	1.8	0.10									
300	5	1.7	1.3	14.1	0.44	5.8	0.18	4.8	0.15	11.3	0.35	4.6	0.15	3.9	0.12	8.5	0.27	3.5	0.11	2.9	0.09	5.6	0.09	2.4	0.08	2.0	0.06									
100	1.7	0.6	0.4	15.1	0.16	6.5	0.07	5.5	0.06	12.1	0.13	5.2	0.05	4.4	0.05	9.0	0.09	3.9	0.04	3.3	0.03	6.0	0.06	2.6	0.03	2.2	0.03									
50	0.8	0.3	0.2	15.8	0.08	6.9	0.04	6.0	0.03	12.6	0.07	5.5	0.03	4.8	0.02	9.5	0.05	4.1	0.02	3.6	0.02	3.2	0.04	2.8	0.02	2.4	0.01									

SJ 50					LOAD																															
n_1 [rpm]	LINEAR SPEED v [mm/s]				50 kN								35 kN								25 kN								10 kN							
					RATIO				RATIO				RATIO				RATIO																			
	RV1	RN1	RL1	RV1	RN1	RL1	RV1	RN1	RL1	RV1	RN1	RL1	RV1	RN1	RL1	RV1	RN1	RL1	RV1	RN1	RL1	RV1	RN1	RL1	RV1	RN1	RL1									
	T_1 Nm	P_1 kW	T_1 Nm	P_1 kW	T_1 Nm	P_1 kW	T_1 Nm	P_1 kW	T_1 Nm	P_1 kW	T_1 Nm	P_1 kW	T_1 Nm	P_1 kW	T_1 Nm	P_1 kW	T_1 Nm	P_1 kW	T_1 Nm	P_1 kW	T_1 Nm	P_1 kW	T_1 Nm	P_1 kW	T_1 Nm	P_1 kW	T_1 Nm	P_1 kW								
1500	25	12.5	6.3	25.0	3.92	14.4	2.26	8.5	1.34	17.5	2.74	10.0	1.58	6.0	0.94	12.5	1.96	7.2	1.13	4.3	0.67	5.0	0.78	2.9	0.45	1.7	0.27									
1000	16.7	8.3	4.2	26.5	2.78	13.3	1.60	9.1	0.96	18.6	1.94	10.7	1.12	6.4	0.67	13.3	1.39	7.6	0.80	4.6	0.48	5.3	0.56	3.1	0.32	1.8	0.19									
750	12.5	6.3	3.1	27.4	2.15	16.0	1.25	9.5	0.74	19.2	1.51	11.1	0.87	6.6	0.52	13.7	1.08	7.9	0.62	4.7	0.37	5.5	0.43	3.2	0.25	1.9	0.15									
500	8.3	4.2	2.1	28.8	1.51	16.4	0.86	10.0	0.52	20.2	1.06	11.5	0.60	7.0	0.37	14.4	0.75	8.2	0.43	5.0	0.26	5.8	0.30	3.3	0.17	2.0	0.11									
300	5	2.5	1.3	30.5	0.96	17.4	0.55	10.8	0.34	21.3	0.67	12.2	0.38	7.6	0.24	15.2	0.48	8.7	0.27	5.4	0.17	6.1	0.19	3.5	0.11	2.1	0.07									
100	1.7	0.8	0.4	33.0	0.35	19.3	0.20	12.5	0.13	23.1	0.24	13.5	0.14	8.8	0.09	16.5	0.17	9.7	0.10	6.3	0.07	6.6	0.07	3.9	0.04	2.5	0.03									
50	0.8	0.4	0.2	35.0	0.18	21.0	0.11	13.6	0.07	24.3	0.13	14.5	0.08	9.5	0.05	17.4	0.09	10.3	0.05	6.8	0.04	7.0	0.04	4.1	0.02	2.7	0.01									

Screw jacks SJ Series - 1-start acme screw

Following tables show the screw jack LINEAR SPEED v [mm/s] and relative TORQUE T_1 [Nm] and POWER P_1 [kW] on input shaft, with reference to the INPUT SPEED n_1 [rpm], the RATIO (RV, RN, RL) and the LOAD [kN] applied on the screw jack.

Intermediate values for linear speed v , torque T_1 and power P_1 at different input speed can be calculated by linear interpolation of the figures stated in the table.

The figures in the tables refer to work with max. duty cycle of 30 % over 10 min time period or 20 % over 1 hour time period at 25°C environment temperature.

ATTENTION! The figures in the **red shaded area** indicate operational restrictions due to thermal limits. When the selection is made within such area, the duty cycle must be reduced or the greater size screw jack must be selected, in order to allow effective heat dissipation. For a better evaluation, please contact SERVOMECH Engineering Dpt.

SJ 100				LOAD																							
				100 kN						80 kN						60 kN						40 kN					
				RATIO			RATIO			RATIO			RATIO			RATIO			RATIO			RATIO					
n_1 [rpm]	LINEAR SPEED v [mm/s]			RV1	RN1	RL1	RV1	RN1	RL1	RV1	RN1	RL1	RV1	RN1	RL1	RV1	RN1	RL1	RV1	RN1	RL1	RV1	RN1	RL1			
	RV1	RN1	RL1	T_1 Nm	P_1 kW	T_1 Nm	P_1 kW	T_1 Nm	P_1 kW	T_1 Nm	P_1 kW	T_1 Nm	P_1 kW	T_1 Nm	P_1 kW	T_1 Nm	P_1 kW	T_1 Nm	P_1 kW	T_1 Nm	P_1 kW	T_1 Nm	P_1 kW	T_1 Nm	P_1 kW		
1 500	32.0	16.0	8.0										16.3	2.56	37.6	5.91	21.8	3.43	12.2	1.92	25.1	3.94	14.6	2.29	8.2	1.28	
1 000	21.4	10.7	5.3			39.1	4.10	25.0	2.62	53.4	5.59	30.2	3.16	17.0	1.78	40.0	4.19	22.6	2.37	12.7	1.33	26.7	2.80	15.1	1.58	8.5	0.89
750	16.1	8.0	4.0	68.4	5.37	42.2	3.31	26.3	2.06	54.7	4.22	32.6	2.56	17.7	1.39	41.0	3.17	24.4	1.92	13.3	1.04	27.3	2.11	16.3	1.28	8.9	0.70
500	10.7	5.3	2.7	73.2	3.83	44.5	2.34	27.5	1.44	58.2	3.05	34.0	1.78	18.5	0.97	43.7	2.29	25.5	1.33	13.9	0.73	29.1	1.52	17.0	0.89	9.3	0.48
300	6.4	3.2	1.6	82.4	2.59	47.6	1.50	30.6	0.96	63.7	2.00	35.1	1.10	22.3	0.70	47.7	1.50	26.3	0.83	16.8	0.53	31.8	1.00	17.5	0.55	11.2	0.35
100	2.1	1.1	0.5	91.5	0.96	55.5	0.58	35.6	0.37	66.2	0.69	37.6	0.39	24.0	0.25	49.7	0.52	28.2	0.30	18.0	0.19	33.1	0.35	18.8	0.20	12.0	0.13
50	1.1	0.5	0.3	98.9	0.52	59.5	0.31	39.9	0.21	69.0	0.36	40.7	0.21	25.5	0.13	51.7	0.27	30.6	0.16	19.1	0.10	34.5	0.18	20.4	0.11	12.7	0.07

SJ 150				LOAD																								
				150 kN						120 kN						80 kN						50 kN						
				RATIO			RATIO			RATIO			RATIO			RATIO			RATIO			RATIO						
n_1 [rpm]	LINEAR SPEED v [mm/s]			RV1	RN1	RL1	RV1	RN1	RL1	RV1	RN1	RL1	RV1	RN1	RL1	RV1	RN1	RL1	RV1	RN1	RL1	RV1	RN1	RL1	RV1	RN1	RL1	
	RV1	RN1	RL1	T_1 Nm	P_1 kW	T_1 Nm	P_1 kW	T_1 Nm	P_1 kW	T_1 Nm	P_1 kW	T_1 Nm	P_1 kW	T_1 Nm	P_1 kW	T_1 Nm	P_1 kW	T_1 Nm	P_1 kW	T_1 Nm	P_1 kW	T_1 Nm	P_1 kW	T_1 Nm	P_1 kW	T_1 Nm	P_1 kW	T_1 Nm
1 500	37.5	12.5	9.4																									
1 000	25	8.3	6.3			46.9	4.91	38.2	4.00			37.5	3.93	30.5	3.20	55.3	5.79	25.0	2.62	20.4	2.13	34.6	3.62	15.6	1.64	12.7	1.33	
750	18.8	6.3	4.7			49.3	3.87	39.0	3.06			39.4	3.09	31.2	2.45	57.3	4.50	26.3	2.06	20.8	1.63	35.8	2.81	16.4	1.29	13.0	1.02	
500	12.5	4.2	3.1	116	6.06	51.1	2.68	41.4	2.17	92.6	4.85	40.9	2.14	33.1	1.73	61.7	3.23	27.3	1.43	22.1	1.16	38.6	2.02	17.0	0.89	13.8	0.72	
300	7.5	2.5	1.9	128	4.01	55.6	2.75	46.8	1.47	102	3.21	44.5	1.40	37.5	1.18	68.0	2.14	29.6	0.93	25.0	0.78	42.5	1.34	18.5	0.58	15.6	0.49	
100	2.5	0.8	0.6	140	1.46	64.4	0.67	54.5	0.57	112	1.17	51.6	0.54	43.6	0.46	74.4	0.78	34.4	0.36	29.1	0.30	46.5	0.49	21.5	0.22	18.2	0.19	
50	1.3	0.4	0.3	150	0.78	72.6	0.38	61.4	0.32	120	0.63	58.1	0.30	49.1	0.26	79.9	0.42	38.7	0.20	32.7	0.17	49.9	0.26	24.2	0.13	20.5	0.11	

SJ 200				LOAD																
				200 kN				150 kN				100 kN				50 kN				
				RATIO		RATIO		RATIO		RATIO		RATIO		RATIO		RATIO		RATIO		
n_1 [rpm]	LINEAR SPEED v [mm/s]		RV1	RL1	RV1	RL1	RV1	RL1	RV1	RL1	RV1	RL1	RV1	RL1	RV1	RL1				
	RV1	RL1	T_1 Nm	P_1 kW	T_1 Nm	P_1 kW	T_1 Nm	P_1 kW	T_1 Nm	P_1 kW	T_1 Nm	P_1 kW	T_1 Nm	P_1 kW	T_1 Nm	P_1 kW				
1 500	42.9	10.7																		
1 000	28.6	7.1			60.1	6.29					45.1	4.72	81.2	8.50	30.0	3.15	40.6	4.25	15.0	1.57
750	21.4	5.4			64.5	5.07	129	10.1	48.4	3.80	86.0	6.76	32.26	2.53	43.0	3.38	16.1	1.27		
500	14.3	3.6	185	9.68	67.6	3.54	139	7.26	50.7	2.5	92.4	4.84	33.8	1.77	46.2	2.42	16.9	0.88		
300	8.6	2.1	201	6.32	75.8	2.38	151	4.74	56.8	1.79	101	3.16	37.9	1.19	50.3	1.58	18.9	0.60		
100	2.9	0.7	228	2.39	86.8	0.91	171	1.79	65.1	0.68	114	1.20	43.4	0.45	57.1	0.60	21.7	0.23		
50	1.4	0.4	252	1.32	98.9	0.52	189	0.99	74.2	0.39	126	0.66	49.4	0.26	62.9	0.33	24.7	0.13		

SJ 250				LOAD															
				250 kN				200 kN				150 kN				100 kN			
				RATIO		RATIO		RATIO		RATIO		RATIO		RATIO		RATIO		RATIO	
n_1 [rpm]	LINEAR SPEED v [mm/s]		RV1	RL1	RV1	RL1	RV1	RL1	RV1	RL1	RV1	RL1	RV1	RL1	RV1	RL1			
	RV1	RL1	T_1 Nm	P_1 kW	T_1 Nm	P_1 kW	T_1 Nm	P_1 kW	T_1 Nm	P_1 kW	T_1 Nm	P_1 kW	T_1 Nm	P_1 kW	T_1 Nm	P_1 kW			
1 500	42.9	10.7																	
1 000	28.6	7.1																	
750	21.4	5.4																	
500	14.3	3.6			87.1	6.84													
300	8.6	2.1	264	8.29	103	3.22	211	6.63	82.1	2.58	158	4.97	61.6	1.93	106	3.31	41.1	1.29	
100	2.9	0.7	313	3.28	119	1.24	251	2.62	95.1	1.00	188	1.97	71.3	0.75	125	1.31	47.5	0.50	
50	1.4	0.4	339	1.77	137	0.72	271	1.42	109	0.57	203	1.06	82.0	0.43	135	0.71	54.7	0.29	



Screw jacks SJ Series - 1-start acme screw

Following tables show the screw jack LINEAR SPEED v [mm/s] and relative TORQUE T_1 [Nm] and POWER P_1 [kW] on input shaft, with reference to the INPUT SPEED n_1 [rpm], the RATIO (RV, RN, RL) and the LOAD [kN] applied on the screw jack.

Intermediate values for linear speed v , torque T_1 and power P_1 at different input speed can be calculated by linear interpolation of the figures stated in the table.

The figures in the tables refer to work with max. duty cycle of 30 % over 10 min time period or 20 % over 1 hour time period at 25°C environment temperature.

ATTENTION! The figures in the **red shaded area** indicate operational restrictions due to thermal limits. When the selection is made within such area, the duty cycle must be reduced or the greater size screw jack must be selected, in order to allow effective heat dissipation. For a better evaluation, please contact SERVOMECH Engineering Dpt.

SJ 300			LOAD															
			300 kN				250 kN				200 kN				100 kN			
			RATIO		RATIO		RATIO		RATIO		RATIO		RATIO		RATIO			
n_1 [rpm]	LINEAR SPEED v [mm/s]		RV1	RL1	RV1	RL1	RV1	RL1	RV1	RL1	RV1	RL1	RV1	RL1	RV1	RL1		
	RV1	RL1	T_1 Nm	P_1 kW	T_1 Nm	P_1 kW	T_1 Nm	P_1 kW	T_1 Nm	P_1 kW	T_1 Nm	P_1 kW	T_1 Nm	P_1 kW	T_1 Nm	P_1 kW		
1 500	31.0	10			86.4	13.6			72.0	11.3	130	20.5	57.6	9.05	65.1	10.2	28.8	4.52
1 000	20.7	6.7			97.0	10.2	176	18.4	80.8	8.46	141	14.8	64.7	6.77	70.4	7.37	32.3	3.39
750	15.5	5	223	17.5	105	8.24	186	14.6	87.4	6.87	149	11.7	69.9	5.49	74.4	5.84	35.0	2.75
500	10.3	3.3	242	12.7	113	5.93	202	10.6	94.3	4.94	161	8.45	75.5	3.95	80.7	4.23	37.7	1.98
300	6.2	2	270	8.48	121	3.80	225	7.06	101	3.16	180	5.65	80.6	2.53	90.0	2.83	40.3	1.27
100	2.1	0.7	307	3.21	148	1.55	256	2.68	123	1.29	205	2.14	98.6	1.03	102	1.07	49.3	0.52
50	1.0	0.3	341	1.78	167	0.87	284	1.49	139	0.73	227	1.19	111	0.58	114	0.59	55.5	0.29

SJ 350			LOAD															
			350 kN				300 kN				200 kN				100 kN			
			RATIO		RATIO		RATIO		RATIO		RATIO		RATIO		RATIO			
n_1 [rpm]	LINEAR SPEED v [mm/s]		RV1	RL1	RV1	RL1	RV1	RL1	RV1	RL1	RV1	RL1	RV1	RL1	RV1	RL1		
	RV1	RL1	T_1 Nm	P_1 kW	T_1 Nm	P_1 kW	T_1 Nm	P_1 kW	T_1 Nm	P_1 kW	T_1 Nm	P_1 kW	T_1 Nm	P_1 kW	T_1 Nm	P_1 kW		
1 500	31.0	10						92.2	14.5			61.4	9.65	66.5	10.5	30.7	4.83	
1 000	20.7	6.7			119	12.5			102	10.7	149	15.6	68.0	7.12	74.6	7.81	34.0	3.56
750	15.5	5			129	10.1	235	18.5	111	8.68	157	12.3	73.7	5.79	78.3	6.15	36.9	2.89
500	10.3	3.3	299	15.6	142	7.4	256	13.4	122	6.37	171	8.94	81.1	4.25	85.3	4.47	40.5	2.12
300	6.2	2	337	10.6	151	4.75	289	9.07	130	4.07	192	6.04	86.4	2.71	96.2	3.02	43.2	1.36
100	2.1	0.7	388	4.06	186	1.95	332	3.48	159	1.67	222	2.32	106	1.11	111	1.16	53.2	0.56
50	1.0	0.3	425	2.22	208	1.09	364	1.91	178	0.93	243	1.27	119	0.62	121	0.64	59.4	0.31

SJ 400			LOAD															
			400 kN				300 kN				200 kN				100 kN			
			RATIO		RATIO		RATIO		RATIO		RATIO		RATIO		RATIO			
n_1 [rpm]	LINEAR SPEED v [mm/s]		RV1	RL1	RV1	RL1	RV1	RL1	RV1	RL1	RV1	RL1	RV1	RL1	RV1	RL1		
	RV1	RL1	T_1 Nm	P_1 kW	T_1 Nm	P_1 kW	T_1 Nm	P_1 kW	T_1 Nm	P_1 kW	T_1 Nm	P_1 kW	T_1 Nm	P_1 kW	T_1 Nm	P_1 kW		
1 500	32.1	10.3			125	19.7	206	32.4	94.1	14.8	137	21.6	62.7	9.86	68.7	10.8	31.4	4.93
1 000	21.4	6.9	303	31.7	141	14.7	227	12.8	106	11.1	152	15.9	70.4	7.37	75.8	7.93	35.2	3.69
750	16.1	5.2	323	25.4	149	11.7	242	19.0	112	8.79	161	12.7	74.6	5.86	80.7	6.34	37.3	2.93
500	10.7	3.4	344	18.3	166	8.71	258	13.5	125	6.53	172	9.01	83.2	4.35	86.1	4.51	41.6	2.18
300	6.4	2.1	393	12.4	178	5.60	295	9.27	134	4.20	197	6.18	89.1	2.80	98.4	3.09	44.5	1.40
100	2.1	0.7	458	4.79	219	2.29	343	3.60	164	1.72	229	2.40	109	1.14	114	1.20	54.7	0.57
50	1.1	0.3	510	2.67	250	1.31	384	2.00	187	0.98	255	1.34	125	0.65	128	0.67	62.4	0.33

SJ 600			LOAD															
			600 kN				500 kN				400 kN				200 kN			
			RATIO		RATIO		RATIO		RATIO		RATIO		RATIO		RATIO			
n_1 [rpm]	LINEAR SPEED v [mm/s]		RV1	RL1	RV1	RL1	RV1	RL1	RV1	RL1	RV1	RL1	RV1	RL1	RV1	RL1		
	RV1	RL1	T_1 Nm	P_1 kW	T_1 Nm	P_1 kW	T_1 Nm	P_1 kW	T_1 Nm	P_1 kW	T_1 Nm	P_1 kW	T_1 Nm	P_1 kW	T_1 Nm	P_1 kW		
1 500	37.5	12.1			220	34.5			183	28.8			146	23.0	155	24.4	73.2	11.5
1 000	25	8.0			241	25.1			200	21.0	349	36.5	160	16.8	174	18.3	80.0	8.38
750	18.8	6.0			263	20.7	471	37.0	219	17.2	377	29.6	175	13.8	188	14.8	87.7	6.88
500	12.5	4.0	608	31.8	292	15.3	507	26.5	243	12.8	405	21.2	195	10.2	203	10.6	97.4	5.50
300	7.5	2.4	671	21.1	316	9.94	559	17.6	264	8.28	447	14.1	211	6.62	224	7.03	105	3.31
100	2.5	0.8	813	8.51	397	4.15	677	7.09	330	3.46	542	5.67	264	2.77	271	2.84	132	1.8
50	1.3	0.4	893	4.68	437	2.29	744	3.90	364	1.91	595	3.12	291	1.52	298	1.56	146	0.76

Screw jacks SJ Series - 1-start acme screw

Following tables show the screw jack LINEAR SPEED v [mm/s] and relative TORQUE T_1 [Nm] and POWER P_1 [kW] on input shaft, with reference to the INPUT SPEED n_1 [rpm], the RATIO (RV, RN, RL) and the LOAD [kN] applied on the screw jack.

Intermediate values for linear speed v , torque T_1 and power P_1 at different input speed can be calculated by linear interpolation of the figures stated in the table.

The figures in the tables refer to work with max. duty cycle of 30 % over 10 min time period or 20 % over 1 hour time period at 25°C environment temperature.

ATTENTION! The figures in the **red shaded area** indicate operational restrictions due to thermal limits. When the selection is made within such area, the duty cycle must be reduced or the greater size screw jack must be selected, in order to allow effective heat dissipation. For a better evaluation, please contact SERVOMECH Engineering Dpt.

SJ 800			LOAD															
			800 kN				600 kN				400 kN				200 kN			
			RATIO		RATIO		RATIO		RATIO		RATIO		RATIO		RATIO			
n_1 [rpm]	LINEAR SPEED v [mm/s]		RV1	RL1	T_1 Nm	P_1 kW	T_1 Nm	P_1 kW	T_1 Nm	P_1 kW	T_1 Nm	P_1 kW	T_1 Nm	P_1 kW	T_1 Nm	P_1 kW	T_1 Nm	P_1 kW
	1 500	30	9.7			263	41.4			197	31.0	280	44.0	132	20.8	140	22.0	65.8
1 000	20	6.5			284	29.8	472	49.4	213	22.3	314	33.0	142	14.9	157	16.5	71.1	7.44
750	15	4.9			309	24.3	501	39.4	232	18.2	334	26.2	155	12.2	167	13.1	77.3	6.07
500	10	3.2	722	37.8	349	18.3	541	28.4	262	13.7	361	18.9	175	9.15	180	9.45	87.4	4.57
300	6	1.9	827	26.0	379	11.9	620	19.5	284	8.94	414	13.0	190	5.95	207	6.50	94.8	2.98
100	2	0.6	978	10.2	480	5.02	733	7.68	360	3.77	489	5.12	240	2.51	244	2.56	120	1.26
50	1	0.3	1 076	5.63	527	2.76	807	4.23	395	2.07	538	2.82	263	1.38	269	1.41	132	0.69

SJ 1000			LOAD															
			1000 kN				800 kN				600 kN				400 kN			
			RATIO		RATIO		RATIO		RATIO		RATIO		RATIO		RATIO			
n_1 [rpm]	LINEAR SPEED v [mm/s]		RV1	RL1	T_1 Nm	P_1 kW	T_1 Nm	P_1 kW	T_1 Nm	P_1 kW	T_1 Nm	P_1 kW	T_1 Nm	P_1 kW	T_1 Nm	P_1 kW	T_1 Nm	P_1 kW
	1 500	34.3	11.1							294	46.2			220	34.7	312	49.0	147
1 000	22.9	7.4			402	42.1			321	33.7	520	54.5	241	25.2	347	36.3	161	16.8
750	17.1	5.6			437	34.3	737	58.0	350	27.5	553	43.5	262	20.6	369	29.0	175	13.7
500	11.4	3.7	1 008	52.8	486	25.4	806	42.2	388	20.3	605	31.7	291	15.2	403	21.1	194	10.1
300	6.9	2.2	1 148	36.1	541	17.0	918	28.9	433	13.6	689	21.6	325	10.2	459	14.4	217	6.80
100	2.3	0.7	1 397	14.6	679	7.11	1 117	11.7	543	5.69	838	8.77	408	4.27	559	5.85	272	2.85
50	1.1	0.4	1 544	8.08	760	3.98	1 235	6.47	608	3.18	926	4.85	456	2.39	618	3.23	304	1.59

Total efficiency of screw jack with 1-start acme screw

η	SJ 5				SJ 10			SJ 25			SJ 50			SJ 100			SJ 150		
	RH1	RV1	RN1	RL1	RV1	RN1	RL1	RV1	RN1	RL1	RV1	RN1	RL1	RV1	RN1	RL1	RV1	RN1	RL1
1 500	0.35	0.34	0.29	0.25	0.36	0.28	0.25	0.34	0.27	0.25	0.32	0.28	0.23	0.33	0.29	0.24	0.37	0.28	0.26
1 000	0.33	0.32	0.28	0.24	0.34	0.27	0.24	0.32	0.26	0.24	0.30	0.26	0.22	0.31	0.27	0.23	0.35	0.25	0.23
750	0.32	0.31	0.27	0.23	0.33	0.26	0.23	0.31	0.25	0.23	0.29	0.25	0.21	0.30	0.26	0.22	0.33	0.24	0.23
500	0.30	0.29	0.26	0.21	0.31	0.25	0.21	0.29	0.24	0.22	0.28	0.24	0.20	0.29	0.25	0.21	0.31	0.23	0.22
300	0.29	0.28	0.25	0.20	0.30	0.24	0.20	0.28	0.23	0.20	0.26	0.23	0.18	0.27	0.24	0.19	0.28	0.21	0.19
100	0.27	0.26	0.23	0.17	0.28	0.22	0.17	0.26	0.20	0.18	0.24	0.21	0.16	0.25	0.22	0.17	0.26	0.19	0.16
50	0.26	0.25	0.21	0.16	0.27	0.20	0.16	0.25	0.19	0.17	0.23	0.19	0.15	0.24	0.20	0.16	0.24	0.16	0.15
AT START	0.22	0.22	0.19	0.15	0.23	0.18	0.14	0.20	0.16	0.13	0.18	0.15	0.11	0.20	0.17	0.13	0.21	0.14	0.13

η	SJ 200		SJ 250		SJ 300		SJ 350		SJ 400		SJ 600		SJ 800		SJ 1000	
	RV1	RL1	RV1	RL1	RV1	RL1	RV1	RL1	RV1	RL1	RV1	RL1	RV1	RL1	RV1	RL1
1 500	0.36	0.26	0.35	0.24	0.30	0.22	0.30	0.21	0.30	0.21	0.31	0.21	0.27	0.19	0.28	0.19
1 000	0.34	0.23	0.31	0.21	0.28	0.20	0.26	0.19	0.27	0.19	0.27	0.19	0.24	0.17	0.25	0.18
750	0.32	0.21	0.30	0.20	0.27	0.18	0.25	0.17	0.25	0.18	0.25	0.18	0.23	0.16	0.24	0.16
500	0.30	0.20	0.28	0.18	0.24	0.17	0.23	0.16	0.24	0.16	0.24	0.16	0.21	0.14	0.22	0.15
300	0.27	0.18	0.26	0.17	0.22	0.16	0.21	0.15	0.21	0.15	0.21	0.15	0.18	0.13	0.19	0.13
100	0.24	0.16	0.22	0.14	0.19	0.13	0.18	0.12	0.18	0.12	0.18	0.12	0.16	0.10	0.16	0.10
50	0.22	0.14	0.20	0.12	0.17	0.11	0.16	0.11	0.16	0.11	0.16	0.11	0.14	0.09	0.14	0.09
AT START	0.19	0.12	0.17	0.11	0.14	0.09	0.13	0.09	0.13	0.08	0.13	0.08	0.11	0.07	0.11	0.07

Screw jacks SJ Series

Screw jacks SJ Series with 2-starts acme screw TECHNICAL SPECIFICATIONS

SCREW JACK SIZE		SJ 5	SJ 10	SJ 25	SJ 50	SJ 100	SJ 150	SJ 200	
Load capacity [kN], (push - pull)		5	10	25	50	100	150	200	
2-starts acme screw		Tr 18x8 (P4)	Tr 22x10 (P5)	Tr 30x12 (P6)	Tr 40x14 (P7)	Tr 55x18 (P9)	Tr 60x24 (P12)	Tr 70x24 (P12)	
Worm gear centre distance [mm]		25	30	50	63	63	80	90	
Available ratio	RH	1 : 4 (5 : 20)	—	—	—	—	—	—	
	RV	1 : 6.25(4 : 25)	1 : 4 (4 : 16)	1 : 6 (4 : 24)	1 : 7 (4 : 28)	1 : 7 (4 : 28)	1 : 8 (4 : 32)	1 : 7 (4 : 28)	
	RN	1 : 12.5(2 : 25)	1 : 16 (2 : 32)	1 : 18 (2 : 36)	1 : 14 (2 : 28)	1 : 14 (2 : 28)	1 : 24	—	
	RL	1 : 25	1 : 24	1 : 24	1 : 28	1 : 28	1 : 32	1 : 28	
Stroke [mm] for 1 input shaft revolution	Ratio	RH1	8	—	—	—	—	—	
		RV1	1.28	2.5	2	2	2.57	3	3.43
		RN1	0.64	0.625	0.67	1	1.29	1	—
		RL1	0.32	0.42	0.5	0.5	0.64	0.75	0.86
Starting efficiency	Ratio	RH1	0.32	—	—	—	—	—	
		RV1	0.32	0.33	0.31	0.29	0.28	0.30	0.28
		RN1	0.28	0.26	0.23	0.24	0.23	0.21	—
		RL1	0.21	0.20	0.20	0.18	0.17	0.19	0.18
Running efficiency at 1500 rpm ⁽¹⁾	Ratio	RH1	0.48	—	—	—	—	—	
		RV1	0.45	0.50	0.47	0.46	0.46	0.49	0.48
		RN1	0.41	0.38	0.38	0.40	0.40	0.39	—
		RL1	0.33	0.34	0.34	0.33	0.33	0.36	0.36
Starting torque on input shaft at max. load [Nm]	Ratio	RH1	5	—	—	—	—	—	
		RV1	3.2	12.2	26.0	56	149	238	391
		RN1	1.9	3.9	11.4	33.5	90	114	—
		RL1	1.2	3.3	10.0	22.4	60	94	153
Max. permissible operating power [kW] ⁽²⁾	Ratio	RH1	0.55	—	—	—	—	—	
		RV1	0.55	0.80	1.6	3.4	3.5	4	5.5
		RN1	0.28	0.40	1	2.4	2.4	3.6	—
		RL1	0.25	0.34	0.8	1.6	1.6	3.5	4.4
Reactive torque on acme screw (nut) required at max. load [Nm]		12	30	100	250	650	1 150	1 700	
Gear box material		casting in aluminium alloy EN 1706 - AC-AISi10Mg T6			casting in cast iron EN-GJL-250 (UNI EN 1561)				
Mass of screw jack without acme screw [kg]		1.5	2.3	10.4	25	35	55	75	
Mass for every 100 mm of acme screw [kg]		0.16	0.23	0.45	0.8	1.6	1.8	2.5	

⁽¹⁾ - efficiency figures at different input speed on page 67

⁽²⁾ - THERMAL limit, referred to work with max. duty cycle 30 % over 10 min time period (20 % over 1 hour time period) at 25°C environment temperature

Screw jacks SJ Series

Screw jacks SJ Series with 2-starts acme screw TECHNICAL SPECIFICATIONS

SJ 250	SJ 300	SJ 350	SJ 400	SJ 600	SJ 800	SJ 1000	SCREW JACK SIZE	
250	300	350	400	600	800	1000	Load capacity [kN], (push - pull)	
Tr 80x24 (P12)	Tr 90x24 (P12)	Tr 100x24 (P12)	Tr 100x24 (P12)	Tr 120x28 (P14)	Tr 140x28 (P14)	Tr 160x32 (P16)	2-starts acme screw	
90	110	110	140	140	200	200	Worm gear centre distance [mm]	
—	—	—	—	—	—	—	RH	
1 : 7 (4 : 28)	3 : 29	3 : 29	3 : 28	3 : 28	3 : 35	3 : 35	RV	
—	—	—	—	—	—	—	RN	
1 : 28	1 : 30	1 : 30	1 : 29	1 : 29	1 : 36	1 : 36	RL	
—	—	—	—	—	—	—	RH1	
3.43	2.48	2.48	2.57	3	2.4	2.74	RV1	
—	—	—	—	—	—	—	RN1	
0.86	0.8	0.8	0.83	0.97	0.78	0.89	RL1	
—	—	—	—	—	—	—	RH1	
0.28	0.23	0.21	0.21	0.20	0.18	0.18	RV1	
—	—	—	—	—	—	—	RN1	
0.18	0.15	0.14	0.13	0.13	0.11	0.11	RL1	
—	—	—	—	—	—	—	RH1	
0.48	0.43	0.42	0.42	0.43	0.40	0.41	RV1	
—	—	—	—	—	—	—	RN1	
0.36	0.33	0.31	0.31	0.31	0.29	0.29	RL1	
—	—	—	—	—	—	—	RH1	
527	521	650	790	1 407	1 685	2 405	RV1	
—	—	—	—	—	—	—	RN1	
206	257	320	399	711	866	1 237	RL1	
—	—	—	—	—	—	—	RH1	
5.5	11	11	21	23	30	36	RV1	
—	—	—	—	—	—	—	RN1	
4.4	9	9	17	20	26	33	RL1	
2 280	2 950	3 680	4 200	7 500	11 100	15 900	Reactive torque on acme screw (nut) required at max. load [Nm]	
casting in cast iron EN-GJL-250 (UNI EN 1561)			casting in steel Fe G 60 (UNI 4010)				Gear box material	
75	120	120	260	260	800	800	Mass of screw jack without acme screw [kg]	
3.4	4.4	5.5	5.5	7.9	10.9	14.2	Mass for every 100 mm of acme screw [kg]	

(¹) - efficiency figures at different input speed on page 67

(²) - THERMAL limit, referred to work with max. duty cycle 30 % over 10 min time period (20 % over 1 hour time period)
at 25°C environment temperature

Screw jacks SJ Series - 2-starts acme screw

Following tables show the screw jack LINEAR SPEED v [mm/s] and relative TORQUE T_1 [Nm] and POWER P_1 [kW] on input shaft, with reference to the INPUT SPEED n_1 [rpm], the RATIO (RV, RN, RL) and the LOAD [kN] applied on the screw jack.

Intermediate values for linear speed v , torque T_1 and power P_1 at different input speed can be calculated by linear interpolation of the figures stated in the table.

The figures in the tables refer to work with max. duty cycle of 30 % over 10 min time period or 20 % over 1 hour time period at 25°C environment temperature.

ATTENTION! The figures in the **red shaded area** indicate operational restrictions due to thermal limits. When the selection is made within such area, the duty cycle must be reduced or the greater size screw jack must be selected, in order to allow effective heat dissipation. For a better evaluation, please contact SERVOMECH Engineering Dpt.

SJ 5					LOAD																								
n_1 [rpm]	LINEAR SPEED v [mm/s]				5 kN								3 kN								1 kN								
	RATIO				RATIO				RATIO				RATIO				RATIO				RATIO								
	RH2	RV2	RN2	RL2	T_1 Nm	P_1 kW	T_1 Nm	P_1 kW	T_1 Nm	P_1 kW	T_1 Nm	P_1 kW	RH2	RV2	RN2	RL2	T_1 Nm	P_1 kW	T_1 Nm	P_1 kW	T_1 Nm	P_1 kW	RH2	RV2	RN2	RL2	T_1 Nm	P_1 kW	T_1 Nm
1500	50	32	16	8	3.4	0.53	2.3	0.35	1.3	0.19	0.8	0.12	2.0	0.32	1.4	0.21	0.8	0.12	0.5	0.07	0.7	0.11	0.5	0.07	0.3	0.04	0.2	0.02	
1000	33.3	21.3	10.7	5.3	3.5	0.37	2.4	0.25	1.4	0.14	0.9	0.09	2.1	0.22	1.4	0.15	0.8	0.09	0.5	0.05	0.7	0.07	0.5	0.05	0.3	0.03	0.2	0.02	
750	25	16	8	4	3.7	0.29	2.5	0.19	1.4	0.11	0.9	0.07	2.2	0.17	1.5	0.12	0.9	0.07	0.5	0.04	0.8	0.06	0.5	0.04	0.3	0.02	0.2	0.01	
500	16.7	10.7	5.3	2.7	3.9	0.20	2.6	0.13	1.5	0.08	0.9	0.05	2.3	0.12	1.5	0.08	0.9	0.05	0.6	0.03	0.8	0.04	0.5	0.03	0.3	0.02	0.2	0.01	
300	10	6.4	3.2	1.6	4.0	0.13	2.7	0.08	1.6	0.05	1.0	0.03	2.4	0.08	1.6	0.05	0.9	0.03	0.6	0.02	0.8	0.03	0.6	0.02	0.3	0.01	0.2	0.01	
100	3.3	2.1	1.1	0.5	4.5	0.05	2.9	0.03	1.7	0.02	1.1	0.01	2.7	0.03	1.7	0.02	1.0	0.01	0.7	0.01	0.9	0.01	0.6	0.01	0.4	0.01	0.3	0.01	
50	1.7	1.1	0.5	0.3	4.6	0.02	3.0	0.02	1.8	0.01	1.2	0.01	2.8	0.01	1.8	0.01	1.1	0.01	0.7	0.01	0.9	0.01	0.6	0.01	0.4	0.01	0.3	0.01	

SJ 10					LOAD																							
n_1 [rpm]	LINEAR SPEED v [mm/s]				10 kN						8 kN						6 kN						2 kN					
	RATIO				RATIO			RATIO			RATIO			RATIO			RATIO											
	RV2	RN2	RL2		T_1 Nm	P_1 kW	T_1 Nm	P_1 kW	T_1 Nm	P_1 kW	RV2	RN2	RL2		T_1 Nm	P_1 kW	T_1 Nm	P_1 kW	T_1 Nm	P_1 kW	RV2	RN2	RL2		T_1 Nm	P_1 kW	T_1 Nm	P_1 kW
1500	62.5	15.6	10.4	8.1	1.26	2.6	0.41	2.0	0.31	6.4	1.01	2.1	0.33	1.6	0.25	4.8	0.76	1.6	0.24	1.2	0.19	1.6	0.25	0.5	0.08	0.4	0.06	
1000	41.7	10.4	6.9	8.4	0.88	2.7	0.28	2.1	0.22	6.8	0.71	2.2	0.23	1.7	0.18	5.1	0.53	1.6	0.17	1.3	0.13	1.7	0.18	0.6	0.06	0.4	0.04	
750	31.3	7.8	5.2	8.7	0.68	2.8	0.22	2.3	0.17	7.0	0.55	2.3	0.18	1.8	0.14	5.2	0.41	1.7	0.13	1.4	0.10	1.8	0.14	0.6	0.04	0.5	0.03	
500	20.8	5.2	3.5	9.2	0.48	2.9	0.15	2.4	0.12	7.4	0.39	2.3	0.12	1.9	0.10	5.5	0.29	1.8	0.09	1.4	0.07	1.9	0.10	0.6	0.03	0.5	0.02	
300	12.5	3.1	2.1	9.8	0.31	3.1	0.10	2.5	0.08	7.8	0.24	2.5	0.08	2.0	0.06	5.9	0.18	1.9	0.06	1.5	0.05	2.0	0.06	0.6	0.02	0.5	0.02	
100	4.2	1.0	0.7	10.7	0.11	3.5	0.04	3.0	0.03	8.6	0.09	2.8	0.03	2.4	0.02	6.4	0.07	2.1	0.02	1.8	0.02	2.2	0.02	0.7	0.01	0.6	0.01	
50	2.1	0.5	0.3	10.9	0.06	3.8	0.02	3.1	0.02	8.7	0.05	3.0	0.02	2.5	0.01	6.6	0.03	2.3	0.01	1.9	0.01	2.2	0.01	0.8	0.01	0.6	0.01	

SJ 25					LOAD																							
n_1 [rpm]	LINEAR SPEED v [mm/s]				25 kN						20 kN						15 kN						10 kN					
	RATIO				RATIO			RATIO			RATIO			RATIO														
	RV2	RN2	RL2		T_1 Nm	P_1 kW	T_1 Nm	P_1 kW	T_1 Nm	P_1 kW	RV2	RN2	RL2		T_1 Nm	P_1 kW	T_1 Nm	P_1 kW	T_1 Nm	P_1 kW	RV2	RN2	RL2		T_1 Nm	P_1 kW	T_1 Nm	P_1 kW
1500	50	16.7	12.5	17.0	2.66	7.0	1.10	5.8	0.91	13.6	2.13	5.6	0.88	4.7	0.73	10.2	1.60	4.2	0.66	3.5	0.55	6.8	1.07	2.8	0.44	2.3	0.36	
1000	33.3	11.1	8.3	17.7	1.85	7.4	0.78	6.1	0.64	14.2	1.48	6.0	0.62	4.9	0.51	10.6	1.11	4.5	0.47	3.7	0.38	7.1	0.74	3.0	0.31	2.5	0.25	
750	25	8.3	6.3	18.2	1.43	7.7	0.60	6.3	0.49	14.6	1.14	6.1	0.48	5.1	0.39	10.9	0.86	4.6	0.36	3.8	0.30	7.3	0.57	3.1	0.24	2.5	0.20	
500	16.7	5.6	4.2	19.5	1.02	8.1	0.42	6.8	0.35	15.6	0.82	6.5	0.34	5.4	0.28	11.7	0.61	4.9	0.25	4.1	0.21	7.8	0.41	3.2	0.17	2.7	0.14	
300	10	3.3	2.5	20.5	0.64	8.6	0.27	7.3	0.23	16.4	0.52	6.9	0.22	5.8	0.18	12.3	0.39	5.2	0.16	4.4	0.14	8.2	0.26	3.4	0.11	2.9	0.09	
100	3.3	1.1	0.8	22.6	0.24	9.8	0.10	8.5	0.09	18.6	0.19	7.8	0.08	6.8	0.07	13.5	0.14	5.9	0.06	5.1	0.05	9.1	0.09	3.9	0.04	3.4	0.04	
50	1.7	0.6	0.4	23.6	0.12	10.4	0.05	9.1	0.05	18.9	0.10	8.3	0.04	7.3	0.04	14.2	0.07	6.2	0.03	5.5	0.03	9.5	0.05	4.2	0.02	3.7	0.02	

SJ 50					LOAD																							
n_1 [rpm]	LINEAR SPEED v [mm/s]				50 kN						35 kN						25 kN						10 kN					
	RATIO				RATIO			RATIO			RATIO			RATIO														
	RV2	RN2	RL2		T_1 Nm	P_1 kW	T_1 Nm	P_1 kW	T_1 Nm	P_1 kW	RV2	RN2	RL2		T_1 Nm	P_1 kW	T_1 Nm	P_1 kW	T_1 Nm	P_1 kW	RV2	RN2	RL2		T_1 Nm	P_1 kW	T_1 Nm	P_1 kW
1500	50	25	12.5	34.8	5.46	20.1	3.15	12.1	1.91	24.3	3.82	14.1	2.21	8.50	1.33	17.4	2.73	10.0	1.58	6.1	0.95	7.0	1.09	4.0	0.63	2.5	0.38	
1000	33.3	16.7	8.3	37.1	3.88	21.3	2.23	13.1	1.37	26.0	2.72	14.9	1.56	9.16	0.96	18.5	1.94	10.6	1.11	6.6	0.69	7.4	0.78	4.3	0.45	2.6	0.27	
750	25	12.5	6.3	38.2	3.00	22.6	1.77	13.5	1.06	26.7	2.10	15.8	1.24	9.45	0.74	19.1	1.50	11.3	0.89	6.7	0.53	7.7	0.60	4.5	0.35	2.7	0.21	
500	16.7	8.3	4.2	40.6	2.13	23.5	1.23	14.4	0.75	28.4	1.49	16.4	0.86	10.1	0.53	20.3	1.06	11.7	0.61	7.2	0.38	8.1	0.43	4.7	0.25	2.9	0.15	
300	10	5	2.5	43.3	1.36	24.8	0.78	15.8	0.49	30.3	0.95	17.3	0.54	11.0	0.35	21.6	0.68	12.4	0.39	7.9	0.25	8.7	0.27	5.0	0.16	3.2	0.10	
100	3.3	1.7	0.8	46.7	0.49	28.0	0.29	18.2	0.19	32.7	0.34	19.6	0.20	12.7	0.13	23.3	0.24	14.0	0.15	9.1	0.10	9.4	0.10	5.6	0.06	3.7	0.04	
50	1.7	0.8	0.4	50.3	0.26	30.4	0.16	20.5	0.11	35.2	0.18	21.3	0.11	14.3	0.08	25.1	0.13	15.2	0.08	10.2	0.05	10.1	0.05	6.1	0.03	4.1	0.02	

Screw jacks SJ Series - 2-starts acme screw

Following tables show the screw jack LINEAR SPEED v [mm/s] and relative TORQUE T_1 [Nm] and POWER P_1 [kW] on input shaft, with reference to the INPUT SPEED n_1 [rpm], the RATIO (RV, RN, RL) and the LOAD [kN] applied on the screw jack.

Intermediate values for linear speed v , torque T_1 and power P_1 at different input speed can be calculated by linear interpolation of the figures stated in the table.

The figures in the tables refer to work with max. duty cycle of 30 % over 10 min time period or 20 % over 1 hour time period at 25°C environment temperature.

ATTENTION! The figures in the **red shaded area** indicate operational restrictions due to thermal limits. When the selection is made within such area, the duty cycle must be reduced or the greater size screw jack must be selected, in order to allow effective heat dissipation. For a better evaluation, please contact SERVOMECH Engineering Dpt.

SJ 100				LOAD																							
n_1 [rpm]	LINEAR SPEED v [mm/s]			100 kN						80 kN						60 kN						40 kN					
	RATIO			RATIO						RATIO						RATIO											
	RV2	RN2	RL2	RV2	RN2	RL2	RV2	RN2	RL2	RV2	RN2	RL2	RV2	RN2	RL2	RV2	RN2	RL2	RV2	RN2	RL2	RV2	RN2	RL2	RV2	RN2	RL2
			T_1 Nm	P_1 kW	T_1 Nm	P_1 kW	T_1 Nm	P_1 kW	T_1 Nm	P_1 kW	T_1 Nm	P_1 kW	T_1 Nm	P_1 kW	T_1 Nm	P_1 kW	T_1 Nm	P_1 kW	T_1 Nm	P_1 kW	T_1 Nm	P_1 kW	T_1 Nm	P_1 kW	T_1 Nm	P_1 kW	
1 500	64.3	32.1	16.1											25.0	3.92	53.7	8.44	30.6	4.81	18.7	2.94	35.8	5.62	20.4	3.20	12.5	1.96
1 000	42.9	21.4	10.7			54.8	5.74	34.2	3.58	76.2	7.98	43.9	4.59	27.4	2.87	57.1	5.98	32.9	3.45	20.5	2.15	38.1	3.99	21.9	2.30	13.7	1.43
750	32.1	16.1	8.0	97.5	7.66	58.4	5.48	35.7	2.80	78.0	6.13	46.7	3.67	28.6	2.24	58.5	4.60	35.0	2.75	21.4	1.68	39.0	3.06	23.4	1.83	14.3	1.12
500	21.4	10.7	5.4	103	5.39	61.3	3.21	37.4	1.96	82.3	4.31	49.1	2.57	30.0	1.57	61.7	3.23	36.8	1.93	22.5	1.18	41.2	2.15	24.5	1.28	15.0	0.78
300	12.9	6.4	3.2	113	3.55	64.8	2.04	41.2	1.29	90.5	2.84	51.8	1.63	32.9	1.03	67.9	2.13	38.9	1.22	24.7	0.78	45.3	1.42	25.9	0.81	16.5	0.52
100	4.3	2.1	1.1	124	1.29	74.1	0.78	47.4	0.50	98.8	1.03	59.3	0.62	37.9	0.40	74.1	0.78	44.5	0.47	28.4	0.30	49.4	0.52	29.6	0.31	19.0	0.20
50	2.1	1.1	0.5	132	0.69	78.8	0.41	52.4	0.27	106	0.55	63.0	0.33	41.9	0.22	79.2	0.41	47.3	0.25	31.4	0.16	52.8	0.28	31.5	0.16	21.0	0.11

SJ 150				LOAD																										
n_1 [rpm]	LINEAR SPEED v [mm/s]			150 kN						120 kN						80 kN						50 kN								
	RATIO			RATIO						RATIO						RATIO														
	RV2	RN2	RL2	RV2	RN2	RL2	RV2	RN2	RL2	RV2	RN2	RL2	RV2	RN2	RL2	RV2	RN2	RL2	RV2	RN2	RL2	RV2	RN2	RL2	RV2	RN2	RL2	RV2	RN2	RL2
			T_1 Nm	P_1 kW	T_1 Nm	P_1 kW	T_1 Nm	P_1 kW	T_1 Nm	P_1 kW	T_1 Nm	P_1 kW	T_1 Nm	P_1 kW	T_1 Nm	P_1 kW	T_1 Nm	P_1 kW	T_1 Nm	P_1 kW	T_1 Nm	P_1 kW	T_1 Nm	P_1 kW	T_1 Nm	P_1 kW	T_1 Nm	P_1 kW	T_1 Nm	P_1 kW
1 500	75	25	18.8					49.7	7.81			48.9	7.68	39.8	6.25			32.6	5.12	26.5	4.16	41.6	7.63	20.4	3.20	16.6	2.60			
1 000	50	16.7	12.5			66.9	7.00	54.1	5.67			53.5	5.60	43.3	4.54	82.3	8.62	35.7	3.73	28.9	3.02	51.5	5.39	22.3	2.33	18.1	1.89			
750	37.5	12.5	9.4			69.9	5.49	55.2	4.33	127	9.98	55.9	4.39	44.2	3.47	84.8	6.66	37.3	2.93	29.4	2.31	53.0	4.16	23.3	1.83	18.4	1.44			
500	25	8.3	6.3	168	8.80	72.4	3.79	58.4	3.06	134	7.04	57.9	3.03	46.7	2.45	89.6	4.69	38.6	2.02	31.1	1.63	56.0	2.93	24.1	1.26	19.5	1.02			
300	15	5	3.8	182	5.70	78.2	2.46	65.1	2.05	145	4.56	62.6	1.97	52.1	1.64	96.8	3.04	41.7	1.31	34.7	1.09	60.5	1.90	26.1	0.82	21.7	0.68			
100	5	1.7	1.3	196	2.06	89.3	0.93	75.0	0.79	157	1.64	71.4	0.75	60.0	0.63	105	1.10	47.6	0.50	40.0	0.42	65.4	0.69	29.7	0.31	25.0	0.26			
50	2.5	0.8	0.6	208	1.09	99.1	0.52	83.2	0.44	167	0.87	79.3	0.42	66.7	0.35	111	0.58	52.9	0.28	44.4	0.23	69.4	0.36	33.0	0.17	27.8	0.15			

SJ 200				LOAD																					
n_1 [rpm]	LINEAR SPEED v [mm/s]			200 kN				150 kN				100 kN				50 kN									
	RATIO			RATIO				RATIO				RATIO													
	RV2	RL2		RV2	RL2		RV2	RL2		RV2	RL2		RV2	RL2		RV2	RL2								
			T_1 Nm	P_1 kW	T_1 Nm	P_1 kW	T_1 Nm	P_1 kW	T_1 Nm	P_1 kW	T_1 Nm	P_1 kW	T_1 Nm	P_1 kW	T_1 Nm	P_1 kW	T_1 Nm	P_1 kW							
1 500	85.7	21.4												56.2	8.83					37.5	5.88	56.5	8.87	18.7	2.94
1 000	57.1	14.3			83.3	8.73								62.5	6.55	119	12.5	41.7	4.36			59.6	6.24	20.8	2.18
750	42.9	10.7			88.7	6.97								66.5	5.23	125	9.80	44.4	3.48			62.4	4.90	22.2	1.74
500	28.6	7.1	263	13.7	92.9	4.87	198	10.3	69.7	3.65	132	6.89	46.5	2.43			65.8	3.45			65.8	3.45	23.2	1.22	
300	17.1	4.3	281	8.84	103	3.24	211	6.63	77.4	2.43	141	4.42	51.6	1.62			70.3	2.21			70.3	2.21	25.8	0.81	
100	5.7	1.4	313	3.28	117	1.22	235	2.46	87.5	0.92	157	1.64	58.3	0.61			78.3	0.82			78.3	0.82	29.2	0.31	
50	2.9	0.7	340	1.78	131	0.69	255	1.33	98.1	0.51	170	0.89	65.4	0.34			84.9	0.44			84.9	0.44	32.7	0.17	

SJ 250				LOAD																								
n_1 [rpm]	LINEAR SPEED v [mm/s]			250 kN				200 kN				150 kN				100 kN												
	RATIO			RATIO				RATIO				RATIO																
	RV2	RL2		RV2	RL2		RV2	RL2		RV2	RL2		RV2	RL2		RV2	RL2											
			T_1 Nm	P_1 kW	T_1 Nm	P_1 kW	T_1 Nm	P_1 kW	T_1 Nm	P_1 kW	T_1 Nm	P_1 kW	T_1 Nm	P_1 kW	T_1 Nm	P_1 kW	T_1 Nm	P_1 kW										
1 500	85.7	21.4																										
1 000	57.1	14.3																										
750	42.9	10.7																										
500	28.6	7.1																										
300	17.1	4.3	364	11.4	137	4.29	291	9.15	109	3.44	218	6.86	82.0	2.58			146	4.57			146	4.57	54.7	1.72				
100	5.7	1.4	419	4.39	156	1.64	335	3.51	125	1.31	252	2.63	93.7	0.98			168	1.76			168	1.76	62.5	0.65				
50	2.9	0.7	449	2.35	177	0.92	359	1.88	141	0.74	269	1.41	106	0.55			179	0.94			179	0.94	70.7	0.37				

Screw jacks SJ Series - 2-starts acme screw

Following tables show the screw jack LINEAR SPEED v [mm/s] and relative TORQUE T_1 [Nm] and POWER P_1 [kW] on input shaft, with reference to the INPUT SPEED n_1 [rpm], the RATIO (RV, RN, RL) and the LOAD [kN] applied on the screw jack.

Intermediate values for linear speed v , torque T_1 and power P_1 at different input speed can be calculated by linear interpolation of the figures stated in the table.

The figures in the tables refer to work with max. duty cycle of 30 % over 10 min time period or 20 % over 1 hour time period at 25°C environment temperature.

ATTENTION! The figures in the **red shaded area** indicate operational restrictions due to thermal limits. When the selection is made within such area, the duty cycle must be reduced or the greater size screw jack must be selected, in order to allow effective heat dissipation. For a better evaluation, please contact SERVOMECH Engineering Dpt.

SJ 300			LOAD															
			300 kN				250 kN				200 kN				100 kN			
			RATIO		RATIO		RATIO		RATIO		RATIO		RATIO		RATIO			
n_1 [rpm]	LINEAR SPEED v [mm/s]		RV2	RL2	T_1 Nm	P_1 kW	T_1 Nm	P_1 kW	T_1 Nm	P_1 kW	T_1 Nm	P_1 kW	T_1 Nm	P_1 kW	T_1 Nm	P_1 kW		
	RV2	RL2																
1 500	62.1	20			117	18.4			97.9	15.4			78.3	12.3	92.5	14.5	39.1	6.15
1 000	41.4	13.3			129	13.5	246	25.7	108	11.3	197	20.6	86.2	9.03	98.3	10.3	43.1	4.51
750	31.0	10	308	24.2	139	10.9	257	20.2	115	9.07	206	16.2	92.4	7.25	103	8.08	46.2	3.63
500	20.7	6.7	329	17.2	148	7.77	274	14.4	124	6.48	219	11.5	99.0	5.18	110	5.75	49.5	2.59
300	12.4	4	359	11.3	158	4.95	299	9.39	131	4.13	239	6.51	105	3.30	120	3.76	52.5	1.65
100	4.1	1.3	402	4.21	190	1.99	335	3.51	158	1.65	268	2.80	126	1.32	138	1.40	63.2	0.66
50	2.1	0.7	439	2.30	212	1.11	366	1.92	177	0.92	293	1.53	141	0.74	146	0.77	70.6	0.37

SJ 350			LOAD															
			350 kN				300 kN				200 kN				100 kN			
			RATIO		RATIO		RATIO		RATIO		RATIO		RATIO		RATIO			
n_1 [rpm]	LINEAR SPEED v [mm/s]		RV2	RL2	T_1 Nm	P_1 kW	T_1 Nm	P_1 kW	T_1 Nm	P_1 kW	T_1 Nm	P_1 kW	T_1 Nm	P_1 kW	T_1 Nm	P_1 kW		
	RV2	RL2																
1 500	62.1	20							123	19.3			82.1	12.9	93.9	14.7	41.0	6.45
1 000	41.4	13.3			157	16.4			134	14.1	205	21.5	89.5	9.37	103	10.7	44.8	4.69
750	31.0	10			168	13.2	320	25.1	144	11.34	213	16.7	96.2	7.56	107	8.37	48.1	3.78
500	20.7	6.7	399	20.9	183	9.57	342	17.9	157	8.20	228	12.0	104	5.47	114	5.98	52.2	2.73
300	12.4	4	441	13.9	194	6.11	378	11.9	167	5.24	252	7.92	111	3.49	126	3.96	55.6	1.75
100	4.1	1.3	499	5.23	235	2.46	428	4.48	201	2.11	285	2.92	134	1.41	143	1.49	67.1	0.70
50	2.1	0.7	540	2.82	260	1.36	462	2.42	223	1.17	308	1.61	148	0.78	154	0.81	74.4	0.39

SJ 400			LOAD															
			400 kN				300 kN				200 kN				100 kN			
			RATIO		RATIO		RATIO		RATIO		RATIO		RATIO		RATIO			
n_1 [rpm]	LINEAR SPEED v [mm/s]		RV2	RL2	T_1 Nm	P_1 kW	T_1 Nm	P_1 kW	T_1 Nm	P_1 kW	T_1 Nm	P_1 kW	T_1 Nm	P_1 kW	T_1 Nm	P_1 kW		
	RV2	RL2																
1 500	64.3	20.7			168	26.4	291	45.7	126	19.8	194	30.4	83.9	13.2	96.2	15.2	42.0	6.59
1 000	42.9	13.8	418	43.8	185	19.3	313	32.8	139	14.5	209	21.9	92.3	9.67	104	10.9	46.2	4.83
750	32.1	10.3	439	34.5	195	15.3	329	25.9	146	11.5	219	17.2	97.4	7.65	110	8.62	48.7	3.83
500	21.4	6.9	464	24.3	214	11.2	348	18.2	161	8.41	232	12.1	108	5.61	116	6.07	53.6	2.80
300	12.9	4.1	516	16.2	229	7.20	387	12.2	172	5.40	258	8.11	115	3.60	129	4.05	57.3	1.80
100	4.3	1.4	589	6.17	276	2.89	442	4.63	207	2.17	295	3.08	138	1.45	142	1.54	69.0	0.72
50	2.1	0.7	646	3.38	313	1.64	485	2.54	234	1.23	323	1.69	156	0.82	162	0.85	78.2	0.41

SJ 600			LOAD															
			600 kN				500 kN				400 kN				200 kN			
			RATIO		RATIO		RATIO		RATIO		RATIO		RATIO		RATIO			
n_1 [rpm]	LINEAR SPEED v [mm/s]		RV2	RL2	T_1 Nm	P_1 kW	T_1 Nm	P_1 kW	T_1 Nm	P_1 kW	T_1 Nm	P_1 kW	T_1 Nm	P_1 kW	T_1 Nm	P_1 kW		
	RV2	RL2																
1 500	75	24.1			294	46.1			245	38.4			196	30.8	221	34.7	97.9	15.4
1 000	50	16.1			317	33.2			264	27.7	482	50.5	211	22.1	241	25.3	106	11.1
750	37.5	12.1			342	26.8	640	50.3	285	22.4	512	40.2	228	17.9	256	20.1	114	8.94
500	25	8.0	816	42.7	377	19.7	680	35.6	314	16.4	544	21.5	251	13.1	272	14.3	126	6.57
300	15	4.8	886	27.9	405	12.7	739	23.2	337	10.6	591	18.6	270	8.48	295	9.28	135	4.24
100	5	1.6	1 041	10.9	498	5.21	867	9.08	415	4.35	694	7.27	332	3.48	347	3.63	166	1.74
50	2.5	0.8	1 128	5.91	547	2.86	940	4.92	456	2.39	752	3.94	365	1.91	376	1.97	182	0.95

Screw jacks SJ Series - 2-starts acme screw

Following tables show the screw jack LINEAR SPEED v [mm/s] and relative TORQUE T_1 [Nm] and POWER P_1 [kW] on input shaft, with reference to the INPUT SPEED n_1 [rpm], the RATIO (RV, RN, RL) and the LOAD [kN] applied on the screw jack.

Intermediate values for linear speed v , torque T_1 and power P_1 at different input speed can be calculated by linear interpolation of the figures stated in the table.

The figures in the tables refer to work with max. duty cycle of 30 % over 10 min time period or 20 % over 1 hour time period at 25°C environment temperature.

ATTENTION! The figures in the **red shaded area** indicate operational restrictions due to thermal limits. When the selection is made within such area, the duty cycle must be reduced or the greater size screw jack must be selected, in order to allow effective heat dissipation. For a better evaluation, please contact SERVOMECH Engineering Dpt.

SJ 800			LOAD															
			800 kN				600 kN				400 kN				200 kN			
			RATIO		RATIO		RATIO		RATIO		RATIO		RATIO		RATIO			
n_1 [rpm]	LINEAR SPEED v [mm/s]		RV2	RL2	T_1 Nm	P_1 kW	T_1 Nm	P_1 kW	T_1 Nm	P_1 kW	T_1 Nm	P_1 kW	T_1 Nm	P_1 kW	T_1 Nm	P_1 kW		
	RV2	RL2																
1 500	60	19.4			343	53.8			257	40.4	385	60.5	171	26.9	192	30.2	85.6	13.5
1 000	40	13.0			366	38.3	631	66.1	274	28.7	421	44.0	183	19.1	210	22.2	91.4	9.57
750	30	9.7	883	69.4	392	30.8	663	52.0	294	23.1	442	34.7	196	15.4	221	17.3	98.1	7.70
500	20	6.5	941	49.3	437	22.9	705	36.9	328	17.2	470	24.6	219	11.4	235	12.3	109	5.72
300	12	3.9	1 054	33.1	474	14.9	790	24.8	355	11.2	527	16.6	237	7.44	263	8.28	118	3.72
100	4	1.3	1 221	12.8	587	6.15	915	9.59	440	4.61	611	6.39	294	3.07	305	3.20	147	1.54
50	2	0.6	1 325	6.94	645	3.38	994	5.20	483	2.53	662	3.47	322	1.69	331	1.73	161	0.84

SJ 1000			LOAD															
			1000 kN				800 kN				600 kN				400 kN			
			RATIO		RATIO		RATIO		RATIO		RATIO		RATIO		RATIO			
n_1 [rpm]	LINEAR SPEED v [mm/s]		RV2	RL2	T_1 Nm	P_1 kW	T_1 Nm	P_1 kW	T_1 Nm	P_1 kW	T_1 Nm	P_1 kW	T_1 Nm	P_1 kW	T_1 Nm	P_1 kW		
	RV2	RL2																
1 500	68.6	22.2			481	75.6			385	60.4			289	45.3	431	67.7	192	30.2
1 000	45.7	14.8			519	54.3			415	43.5	703	73.6	311	32.6	468	49.1	207	21.7
750	34.3	11.1			556	43.7	983	77.2	445	35.0	737	57.9	334	26.2	491	38.6	223	17.5
500	22.9	7.4	1 324	69.3	612	32.0	1 059	55.4	490	25.6	794	41.6	367	19.2	529	27.7	245	12.8
300	13.7	4.4	1 471	46.2	676	21.3	1 176	37.0	541	17.0	882	27.7	406	12.8	588	18.5	271	8.50
100	4.6	1.5	1 745	18.3	834	8.73	1 396	14.6	667	6.99	1 047	11.0	500	5.24	698	7.31	334	3.49
50	2.3	0.7	1 908	9.99	926	4.85	1 526	7.99	741	3.88	1 145	5.99	556	2.91	763	4.00	370	1.94

Total efficiency of screw jack with 2-starts acme screw

η	SJ 5				SJ 10			SJ 25			SJ 50			SJ 100			SJ 150		
	RH2	RV2	RN2	RL2	RV2	RN2	RL2	RV2	RN2	RL2	RV2	RN2	RL2	RV2	RN2	RL2	RV2	RN2	RL2
1 500	0.48	0.45	0.41	0.33	0.50	0.38	0.34	0.47	0.38	0.34	0.46	0.40	0.33	0.46	0.40	0.33	0.49	0.39	0.36
1 000	0.45	0.43	0.38	0.31	0.47	0.37	0.32	0.45	0.36	0.33	0.43	0.37	0.30	0.43	0.37	0.30	0.46	0.36	0.33
750	0.44	0.41	0.37	0.29	0.46	0.35	0.30	0.44	0.35	0.32	0.42	0.35	0.29	0.42	0.35	0.29	0.45	0.34	0.32
500	0.41	0.40	0.36	0.28	0.43	0.34	0.28	0.41	0.33	0.30	0.39	0.34	0.28	0.40	0.33	0.27	0.43	0.33	0.31
300	0.40	0.39	0.33	0.27	0.41	0.32	0.27	0.39	0.31	0.27	0.37	0.32	0.25	0.36	0.32	0.25	0.39	0.31	0.27
100	0.36	0.36	0.30	0.23	0.37	0.28	0.22	0.35	0.27	0.24	0.34	0.28	0.22	0.33	0.28	0.22	0.36	0.27	0.24
50	0.35	0.34	0.29	0.22	0.37	0.27	0.21	0.34	0.26	0.22	0.32	0.26	0.19	0.31	0.26	0.20	0.34	0.24	0.21
AT START	0.32	0.32	0.28	0.21	0.33	0.26	0.20	0.31	0.23	0.20	0.29	0.24	0.18	0.28	0.23	0.17	0.30	0.21	0.19

η	SJ 200		SJ 250		SJ 300		SJ 350		SJ 400		SJ 600		SJ 800		SJ 1000	
	RV2	RL2	RV2	RL2	RV2	RL2	RV2	RL2	RV2	RL2	RV2	RL2	RV2	RL2	RV2	RL2
1 500	0.48	0.36	0.47	0.34	0.43	0.33	0.42	0.31	0.42	0.31	0.43	0.31	0.40	0.29	0.41	0.29
1 000	0.46	0.33	0.44	0.31	0.40	0.30	0.39	0.28	0.39	0.29	0.40	0.29	0.36	0.27	0.37	0.27
750	0.44	0.31	0.42	0.29	0.38	0.28	0.37	0.26	0.37	0.27	0.37	0.27	0.35	0.25	0.36	0.25
500	0.41	0.29	0.40	0.27	0.36	0.26	0.35	0.24	0.35	0.25	0.35	0.24	0.32	0.23	0.33	0.23
300	0.39	0.26	0.37	0.25	0.33	0.24	0.31	0.23	0.32	0.23	0.32	0.23	0.32	0.23	0.30	0.21
100	0.35	0.23	0.33	0.22	0.30	0.20	0.28	0.19	0.28	0.19	0.28	0.19	0.25	0.17	0.25	0.17
50	0.32	0.21	0.30	0.19	0.27	0.18	0.26	0.17	0.25	0.17	0.25	0.17	0.23	0.15	0.23	0.15
AT START	0.28	0.19	0.26	0.17	0.23	0.15	0.21	0.14	0.21	0.13	0.20	0.13	0.18	0.11	0.18	0.11

Screw jacks SJ Series - overall dimensions

Model A - TRAVELLING SCREW

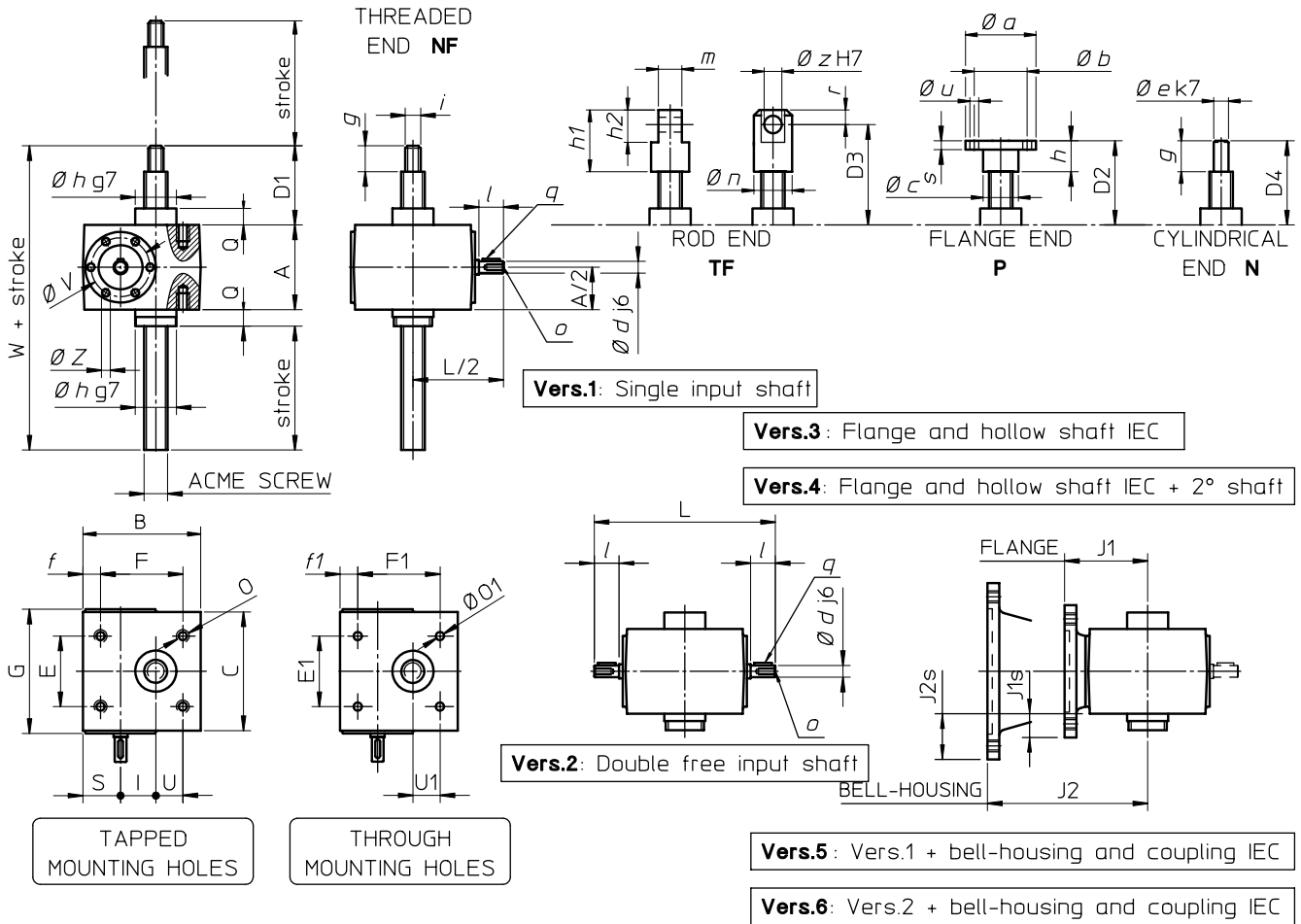

3

Model B - TRAVELLING NUT

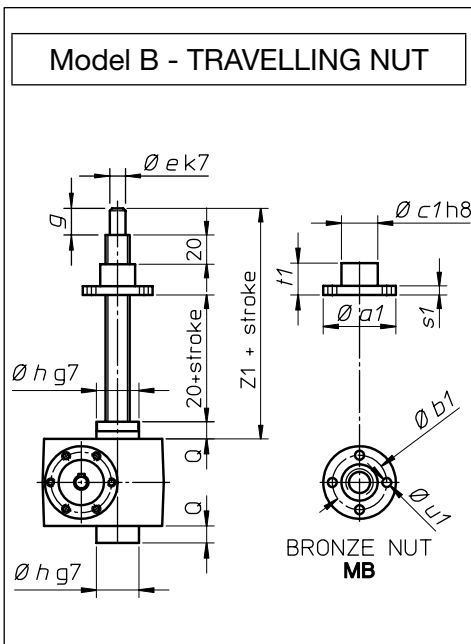

PROTECTIVE TUBE T

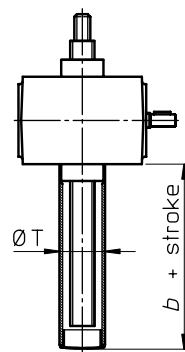

ANTI-TURN DEVICE AR

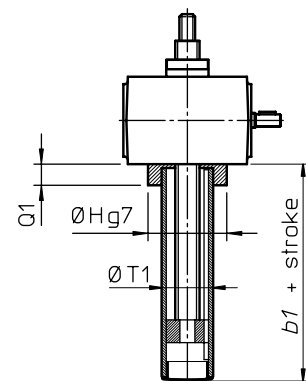

SIZE	SJ 5	SJ 10	SJ 25	SJ 50	SJ 100	SJ 150	SJ 200	SJ 250
ØT	35	40	50	65	102	102	130	130
exec. T	37	43	48	57	65	65	75	75
b								
exec. T + SN	87	93	128	137	155	155	155	155
exec. T + FCM	86	93	98	-	-	-	-	-
exec. T + FCP	87	93	98	107	115	115	115	115
ØH	55	70	85	115	-	-	-	-
Q1	21	18	25	32	-	-	-	-
ØT1	45	55	70	90	100	100	130	130
b1								
exec. AR	86	88	105	102	135	145	135	145
exec. AR + FCP	96	98	115	122	135	145	135	145

Screw jacks SJ Series - overall dimensions

SIZE	SJ 5	SJ 10	SJ 25	SJ 50	SJ 100	SJ 150	SJ 200	SJ 250
ACME SCREW	Tr 18x4	Tr 22x 5	Tr 30x6	Tr 40x7	Tr 55x9	Tr 60x12	Tr 70x12	Tr 80x12
A	62	76	82	118	160	164	176	176
B	100	110	160	200	220	282	280	280
C	86	96	130	160	170	201	230	230
D1 (min.)	51	62	81	90	108	108	118	118
D2 (min.)	52	63	83	92	110	110	120	120
D3 (min.)	77	93	118	137	160	190	210	210
D4 (min.)	51	62	81	90	108	108	118	118
E	52	63	81	115	134	150	180	180
E1	56	80	102	130	120	150	180	180
F	60	78	106	150	175	220	230	230
F1	80	85	131	165	180	220	230	230
G	90	100	136	165	165	205	—	—
I	25	30	50	63	63	80	90	90
L	135	165	221.5	269	269	330	350	350
O	M8, depth 14	M8, depth 15	M10, depth 15	M12, depth 16	M20, depth. 30	M30, depth 45	M30, depth 45	M30, depth 45
∅ O1	9	9	11	13	17	28	32	32
Q	12	18	23	32	40	40	40	40
S	37	40	50	59	74	94	75	75
U	21	29	42	63	60	75	90	90
U1	28	30	48	60	63	75	90	90
∅ V	46	46	64	63	63	—	—	—
W	125	156	186	240	308	312	334	334
Z	M6, depth 13 (4 holes at 90°)	M5, depth 10 (6 holes at 60°)	M5, depth 10 (6 holes at 60°)	M6, depth 14 (6 holes at 60°)	M6, depth 14 (6 holes at 60°)	—	—	—
Z1	111	127	151	185	228	228	268	248
∅ a	68	75	100	120	150	150	180	180
∅ a1	68	75	100	120	130	150	180	190
∅ b	45	55	75	85	110	110	130	130
∅ b1	50	56	75	90	105	120	140	150
∅ c	25	30	40	50	70	70	85	85
∅ c1	30	40	50	60	75	80	100	110
∅ d	9	14	19	24	24	28	30	30
∅ e	12	15	20	30	40	40	50	60
f	23	21	36	35	22	29	25	25
f1	10	15	17	17	20	29	25	25
g	19	24	38	38	48	48	58	58
h	20	25	40	40	50	50	60	60
∅ h	30	38.7	46	60	90	90	120	120
h1	60	75	100	120	140	180	210	210
h2	30	40	50	70	80	100	120	120
i	M12x1.75	M16x1.5	M20x1.5	M30x2	M42x3	M42x3	M56x3	M56x3
l	20	30	40	50	50	60	55	55
m	20	25	30	40	50	60	75	75
∅ n	32	38	48	68	78	90	108	108
o	M4, depth 8	M6, depth 14	M8, depth 16	M8, depth 16	M8, depth 16	M8, depth 16	M10, depth 18	M10, depth 18
q	3x3x15	5x5x20	6x6x30	8x7x40	8x7x40	8x7x40	8x7x45	8x7x45
r	15	20	25	35	40	50	60	60
s	8	10	12	15	20	20	25	25
s1	12	12	15	25	20	30	35	30
t1	40	45	50	75	100	100	130	110
∅ u, n° holes	∅ 7, 4 holes	∅ 9, 4 holes	∅ 11, 4 holes	∅ 17, 4 holes	∅ 21, 4 holes	∅ 21, 4 holes	∅ 26, 6 holes	∅ 26, 6 holes
∅ u1, n° holes	∅ 7, 4 holes	∅ 9, 4 holes	∅ 11, 4 holes	∅ 17, 4 holes	∅ 17, 4 holes	∅ 21, 4 holes	∅ 26, 6 holes	∅ 18, 4 holes
∅ z	14	20	25	35	40	50	60	60
J1	56 B5/B14: 57.5	63 B5/B14: 62	63/71 B5: 102	80 B5: 100	80 B5: 100	80/90 B5: 120	100/112 B5: 170	100/112 B5: 170
J1s	56 B5: 29 56 B14: 9	63 B5: 32 63 B14: 7	63 B5: 29 71 B5: 39	80 B5: 41	80 B5: 20	80/90 B5: 18	100/112 B5: 37	100/112 B5: 37
J2	63 B5: 98	71 B5: 122 71 B14: 131	80 B5: 182 80 B14: 176 90 B5: 182 90 B14: 182	90 B5: 200 90 B14: 200 100 B5: 220 100 B14: 220	90 B5: 200 90 B14: 200 100/112 B5: 220 100/112 B14: 220	100/112 B5: 240 100/112 B14: 240	132 B5: 292	132 B5: 292
J2s	63 B5: 39	71 B5: 42 71 B14: 15	80 B5: 59 80 B14: 19 90 B5: 59 90 B14: 29	90 B5: 41 90 B14: 11 100 B5: 66 100 B14: 21	90 B5: 20 90 B14: — 100/112 B5: 45 100/112 B14: —	100/112 B5: 43 100/112 B14: —	132 B5: 62	132 B5: 62

Screw jacks SJ Series - overall dimensions

Model A - TRAVELLING SCREW

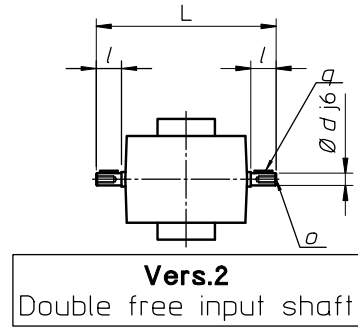
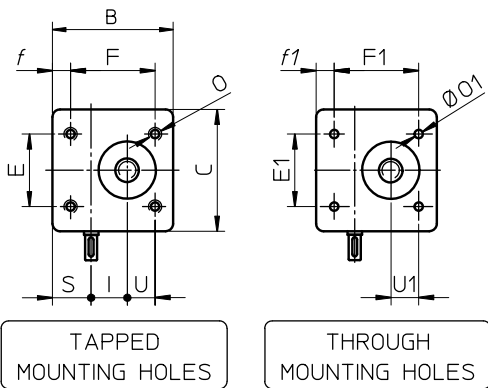
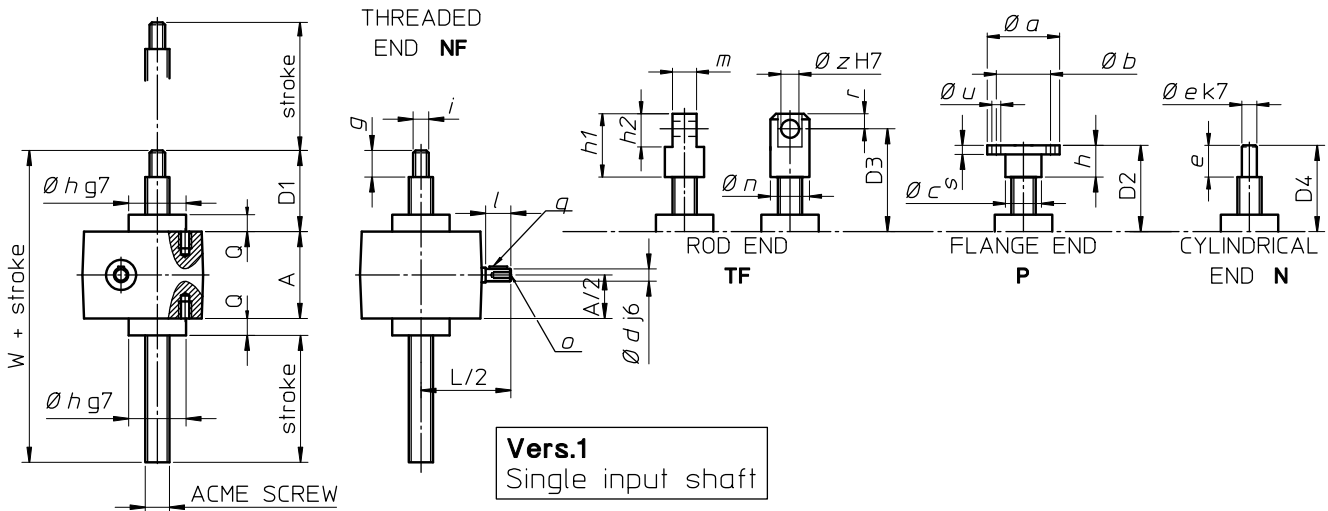

PROTECTIVE TUBE T

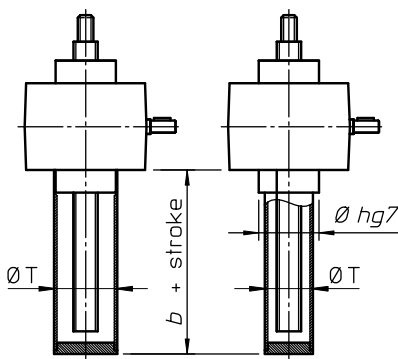

ANTI-TURN DEVICE AR

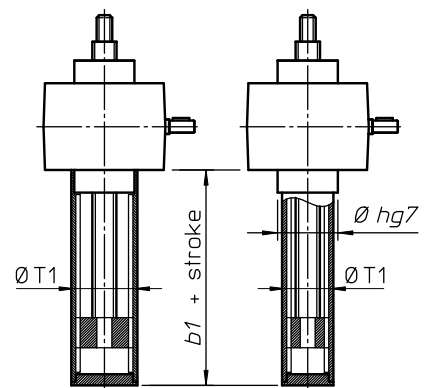

SJ 300
SJ 350

SJ 400
SJ 600
SJ 800
SJ 1000

SJ 300
SJ 350

SJ 400
SJ 600
SJ 800
SJ 1000

Model B - TRAVELLING NUT

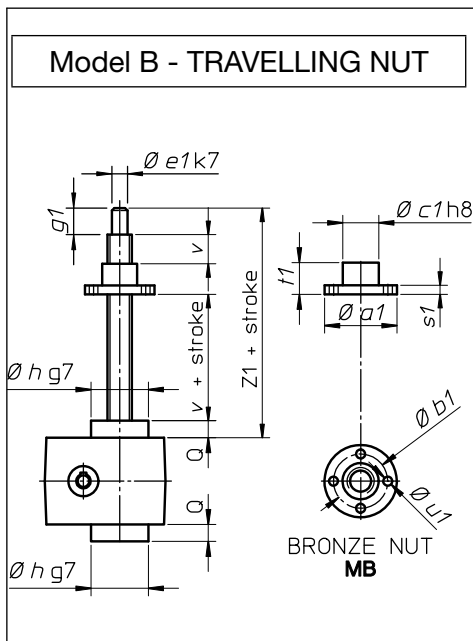

SIZE	SJ 300	SJ 350	SJ 400	SJ 600	SJ 800	SJ 1000
ØT	150	150	200	200	200	200
exec. T	110	110	110	110	130	130
b exec. T + SN	210	210	210	210	250	250
exec. T + FCP	160	160	160	160	190	190
ØT1	160	160	200	200	273	273
b1 exec. AR	190	200	140	150	180	190
exec. AR + FCP	190	200	170	180	210	220

Screw jacks SJ Series - overall dimensions

SIZE	SJ 300	SJ 350	SJ 400	SJ 600	SJ 800	SJ 1000
ACME SCREW	Tr 90x12	Tr 100x12	Tr 100x12	Tr 120x14	Tr 140x14	Tr 160x16
A	230	230	270	270	370	370
B	320	320	405	405	610	610
C	250	250	290	290	500	500
D1 (min.)	158	158	158	178	220	235
D2 (min.)	160	160	160	170	210	210
D3 (min.)	290	290	290	340	410	430
D4 (min.)	210	210	210	240	260	260
E	200	200	230	230	360	360
E1	200	200	230	230	360	360
F	270	270	355	355	510	510
F1	270	270	355	355	510	510
I	110	110	140	140	200	200
L	390	390	490	490	780	780
O	M30, depth 45	M30, depth 45	M30, depth 45	M30, depth 45	M56, depth 110	M56, depth 110
∅ O1	32	32	32	32	63	63
Q	50	50	50	50	60	60
S	85	85	105	105	170	170
U	100	100	135	135	190	190
U1	100	100	135	135	190	190
W	438	438	598	618	650	665
Z1	340	345	345	375	530	530
∅ a	250	278	278	298	378	378
∅ a1	230	230	230	280	320	320
∅ b	180	220	220	240	300	300
∅ b1	190	190	190	235	270	270
∅ c	115	150	150	170	210	210
∅ c1	150	150	150	180	210	210
∅ d	40	40	55	55	70	70
e	120	120	120	150	150	150
∅ e	70	85	85	100	120	140
∅ e1	70	70	70	90	120	130
f	25	25	25	25	50	50
f1	25	25	25	25	50	50
g	68	68	68	88	110	125
g1	80	80	80	85	120	120
h	70	70	70	80	100	100
∅ h	150	150	210	210	300	300
h1	280	280	280	350	440	460
h2	160	160	160	200	280	280
i	M70x6	M70x6	M70x6	M90x6	M110x6	M125x6
l	65	65	75	75	130	130
m	100	100	100	120	155	155
∅ n	138	138	138	168	216	216
o	M10, depth 22	M10, depth 22	M12, depth 28	M12, depth 28	M14, depth 30	M14, depth 30
q	12x8x55	12x8x55	16x10x60	16x10x60	20x12x110	20x12x110
r	80	80	80	100	140	140
s	40	40	40	50	60	60
s1	45	45	45	55	80	80
t1	135	135	135	160	250	250
∅ u, n° holes	∅ 29, 6 holes	∅ 29, 6 holes	∅ 29, 6 holes	∅ 32, 6 holes	∅ 52, 6 holes	∅ 52, 6 holes
∅ u1, n° holes	∅ 20, 4 holes	∅ 20, 4 holes	∅ 20, 4 holes	∅ 25, 4 holes	∅ 25, 6 holes	∅ 25, 6 holes
v	40	40	40	40	50	50
∅ z	80	80	80	100	140	140

Screw jacks SJ Series - options

Screw jack housing fixing holes

On the gear housing of screw jack SJ Series there are fixing holes, which can be tapped holes (on both housing fixing planes) or through holes.

Note that position of threaded holes on the fixing plane differs from the positions of the through holes.

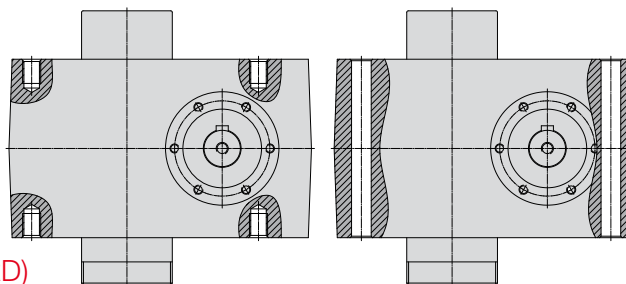

Ordering code: **FF** for threaded holes (STANDARD)
 Ordering code: **FP** for through holes (ON REQUEST)

Stop nut

Available for screw jacks with travelling screw (Mod. A) only.

The mechanical stop prevents the acme screw thread unscrewing clear of the screw jack housing. It is a washer pinned at the acme screw end (opposite the attachment side) that blocks the screw translation when reaching the relative stop.

The acme screw length is defined to allow, under normal use, at the maximum extended position, 20 mm of additional stroke (safety extra-stroke).

If the mechanical stop reaches accidentally the relative stop, it is necessary to check the screw jacks components to verify possible damages.

Ordering code: **SN**

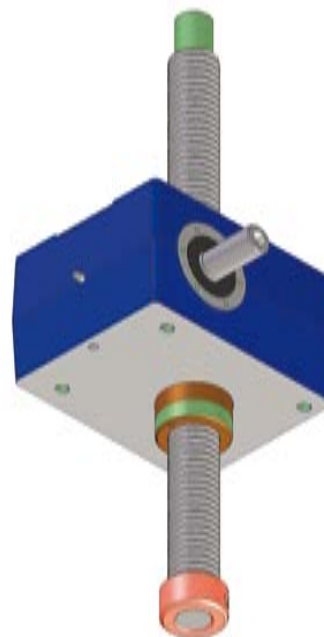

Protective tube

Available for screw jacks with travelling screw (Mod. A) only.

The protective tube is screwed in the raised cover CA and encloses the acme screw below the housing, protecting it from damages and/or environment pollution such as dust, water, etc. Furthermore, it allows the fitting of other options such as limit switches and/or anti-turn device.

Material is aluminium or steel if anti-turn device is fitted.

Ordering code: **T**



3

Screw jacks SJ Series - options

Anti-turn device

Available for screw jacks with travelling screw (Mod. A) only.

The anti-turn device is necessary when the load to be lifted may turn, i.e. the screw guidance does not prevent rotation, or in case the application does not properly allow the acme screw reaction to permit the translation.

Functioning: a steel key is fitted along the protective tube and a keyed bronze washer is fixed at the end of the acme screw; this prevents the screw rotation and forces the screw translation.

Up to screw jack size 50 (acme screw Tr 40x7) included, the anti-turn device has only one key; from size 100 (acme screw Tr 55 x9) on, it has two keys.

The bronze bush also acts as a stop nut against acme screw unthreading.

Ordering code: **AR**

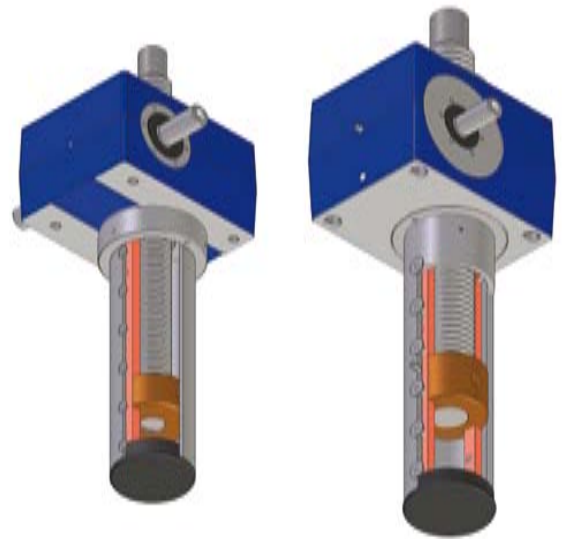

Trunnion mount

Available for both screw jacks models: with travelling screw (Mod. A) and with travelling nut (Mod. B).

The trunnion mount bolts on to either the top or the bottom of the screw jack housing and allows pivoting of the screw jack around the axis defined by trunnion mount's lateral pins.

On screw jack Mod. A: the acme screw attachment must have a cylindrical hole with axis parallel to the trunnion mount lateral pin axis.

On screw jack Mod. B: the part of the machine where the bronze nut MB is fixed must have two lateral cylindrical pins (or holes) with axis parallel to the trunnion mount lateral pin axis.

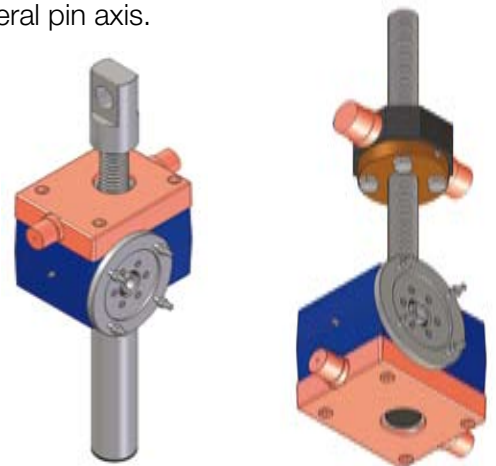
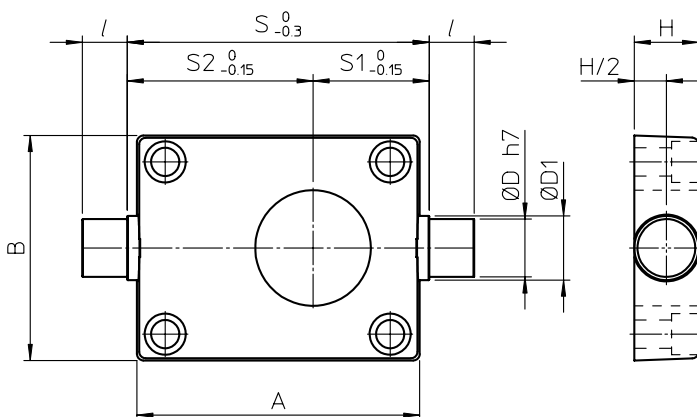

	SJ 5	SJ 10	SJ 25	SJ 50	SJ 100	SJ 150	SJ 200	SJ 250	SJ 300	SJ 350
A	100	110	160	200	220	276	280	280	312	312
B	86	96	130	160	170	200	230	230	242	242
ØD	15	20	25	35	45	60	70	70	65	65
ØD ₁	20	25	30	40	50	70	90	90	85	85
H	20	25	30	40	50	100	120	120	120	120
l	15	20	30	30	35	65	75	75	65	65
S	105	115	185	215	235	305	300	300	350	350
S ₁	40.5	42.5	72.5	85.5	90.5	119.5	125	125	140	140
S ₂	64.5	72.5	112.5	129.5	144.5	185.5	175	175	210	210
mass [kg]	1.1	1.8	3.4	7.3	9	30	40	40	40	40

Ordering code: **SC (TF side)** screw jacks Mod. A with SC fitted on side towards screw attachment
 Ordering code: **SC (opp. TF side)** screw jacks Mod. A with SC fitted on side opposite to screw attachment

Ordering code: **SC (screw side)** screw jacks Mod. B with SC fitted on side towards screw
 Ordering code: **SC (opp. screw side)** screw jacks Mod. B with SC fitted on side opposite to screw

Screw jacks SJ Series - options

Bellows

Available for both screw jacks models: with travelling screw (Mod. A) and with travelling nut (Mod. B). In applications with particular environment conditions, bellows protect the screw from contaminants. The usually supplied bellows are circular, sewn (double seam), in NYLON with a PVC outside and inside coating. For special application requirements, different executions or materials can be supplied on request.

The bellows cause changes to the retracted and extended lengths and screw jack overall dimensions stated in the catalogue. On request, orders will be acknowledged with a screw jack drawing giving exact dimensions.



Screw jacks SJ Mod.A with bellows

Usually, bellows are fitted between the acme screw attachment and worm gear-box, and at the opposite side the protection tube is fitted.

In case the screw jack shall have a screw without attachment, it is recommended to order it with a sketch of the required bellows attachment dimensions.

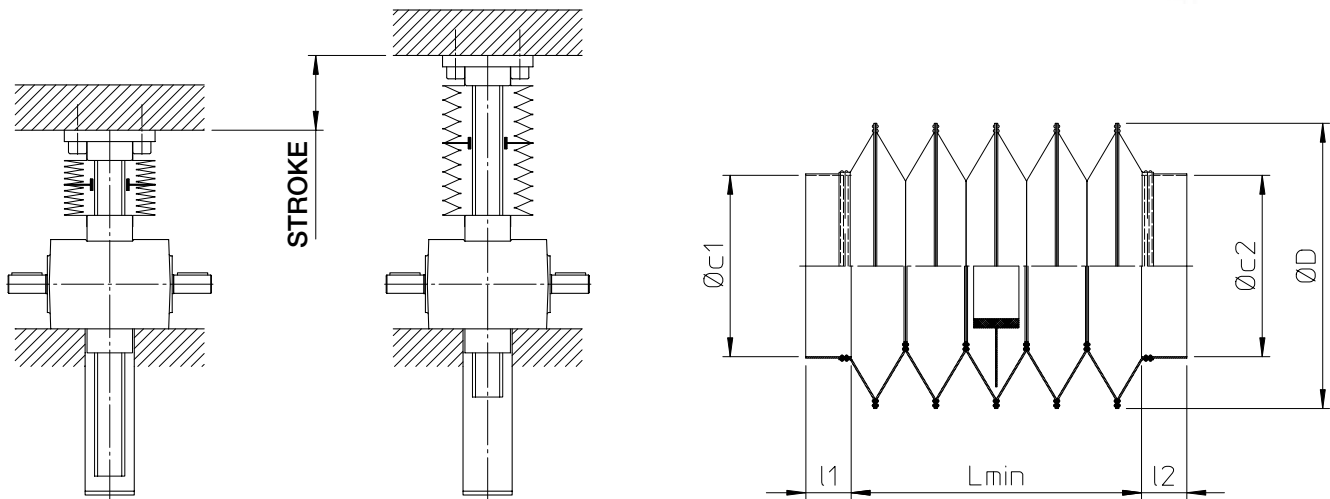

Following table shows the bellows available on stock:

- execution: circular, sewn;
- material: NYLON with a PVC outside and inside coating;
- stroke: 300 mm, 600 mm or 1 000 mm; on request, bellows for different stroke can be supplied;
- dimensions of two attachments suitable for fitting to the screw jack housing and to the flange end P.

	SJ 5	SJ 10	SJ 25	SJ 50	SJ 100
Ø D	65	80	100	120	120
L _{min} (for C300)	80	40	50	—	—
L _{min} (for C600)	180	90	90	90	90
L _{min} (for C1000)	—	—	144	144	144
Ø c1	32	40	47	61	91
l1	10	10	10	20	20
Ø c2	26	31	41	51	71
l2	10	10	10	20	20

Ordering code: **B**

Screw jacks SJ Series - options

Screw jacks SJ Mod.B with bellows

Bellows are normally fitted between the screw jack housing and the nut and also between the nut and the acme screw end. Some applications may require bellows in only one of these two position.

The dimension of the bellows attachment between screw jack housing and bronze nut is determined by the screw jack's dimensions while the bellows attachment between bronze nut and acme screw end depends on the application structure the bellows shall fit.

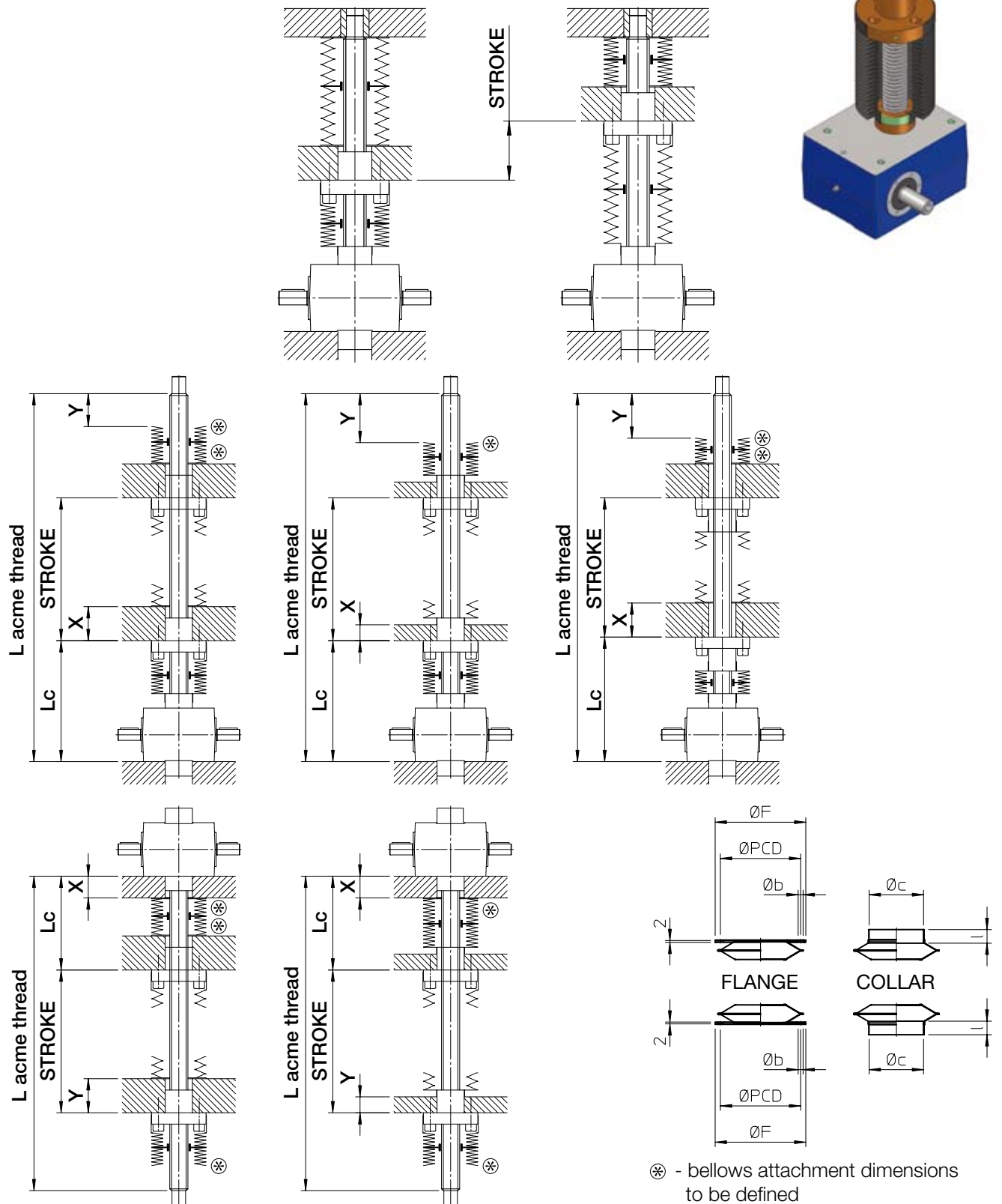
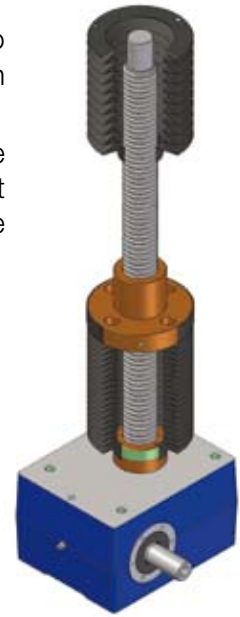

Screw jacks SJ Series - options

Safety nut

Available for both screw jacks models: with travelling screw (Mod. A) and with travelling nut (Mod. B).

The safety nut is a back-up feature to prevent the load dropping in an uncontrolled manner in the event of working nut thread breaking due to overload or achieving of critical wear level (wear level that causes the breaking of the remaining thread section with normal working load only).

The safety nut is an extension to the standard nut (wormwheel inside Mod.A screw jacks or external travelling nut of Mod.B screw jacks) and changes the screw jack overall dimensions.

The safety nut works with one particular load direction only. Its position as regards the standard nut is conditioned by the load direction.

Following drawings show a screw jack with safety nut in case of acme screw subjected to push load. In case of pull load, the position of the nut would be on the opposite side of the screw jack housing (Mod. A) or of the external travelling nut (Mod. B).

By new screw jacks, the distance **b** between standard nut and safety nut is equal to the half of the profile pitch (**P**) of the acme thread.

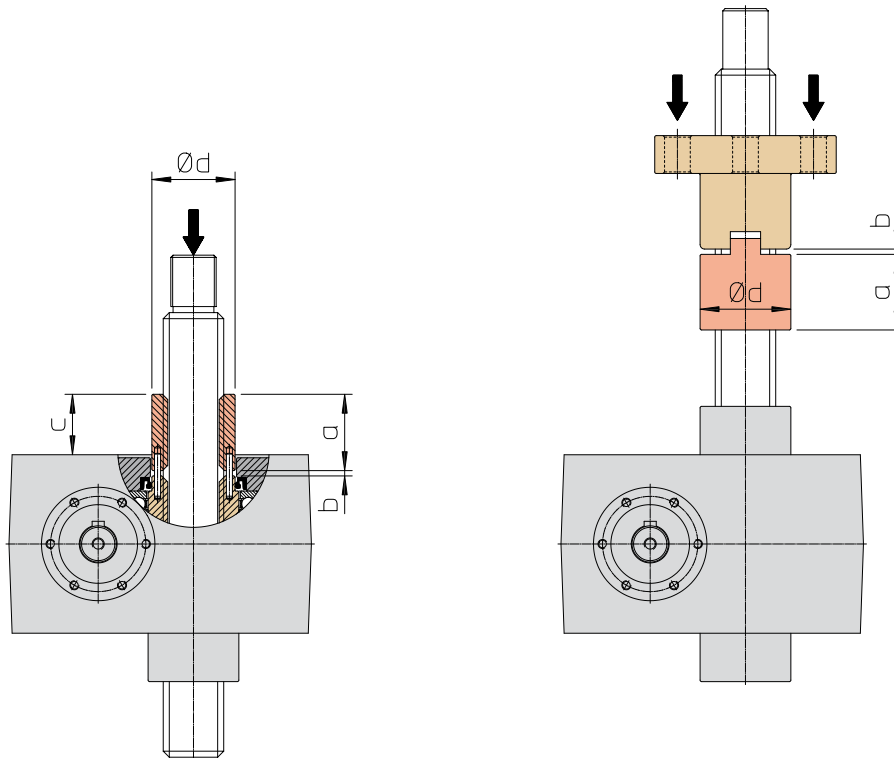

Screw jacks SJ Mod.A with safety nut

	SJ 5	SJ 10	SJ 25	SJ 50	SJ 100	SJ 150	SJ 200	SJ 250	SJ 300	SJ 350	SJ 400	SJ 600	SJ 800	SJ 1000
a	—	33	40	50	70	70	95	95	135	135	135	160	250	250
b	—	2.5	3	3.5	4.5	6	6	6	6	6	6	7	7	8
$\varnothing d$	—	30	50	55	70	80	100	100	130	140	150	160	240	240
c	—	14.5	30.5	39.5	73.5	61	88	88	114	114	114	140	215	216

Ordering code: **MSA push** screw jacks Mod.A with safety nut for push load

Ordering code: **MSA pull** screw jacks Mod.A with safety nut for pull load

Screw jacks SJ Mod.B with safety nut

	SJ 5	SJ 10	SJ 25	SJ 50	SJ 100	SJ 150	SJ 200	SJ 250	SJ 300	SJ 350	SJ 400	SJ 600	SJ 800	SJ 1000
a	28	33	35	50	70	70	95	95	135	135	135	160	250	250
b	2	2.5	3	3.5	4.5	6	6	6	6	6	6	7	7	8
$\varnothing d$	30	40	50	60	75	80	100	100	150	150	150	180	210	210

Ordering code: **SBC push** screw jacks Mod.B with safety nut for push load

Ordering code: **SBC pull** screw jacks Mod.B with safety nut for pull load

Screw jacks SJ Series - options

Acme thread wear level check

Available for both screw jacks models: with travelling screw (Mod. A) and with travelling nut (Mod. B).

Due to working conditions (load, speed, temperature, lubrication), the thread of the working nut wears out. Some applications require the possibility to keep the current wear level under control to prevent reaching the critical wear level and consequent thread breaking by replacing the nut early.

Usually, a value equal to 1/4 of the profile pitch (**P**) of the acme thread is considered as max. wear level admitted.

With thread wear, the distance **b** between working nut and safety nut (see drawings on previous page) reduces to the working nut. By measuring this change, it is possible to get the current wear level of the thread.

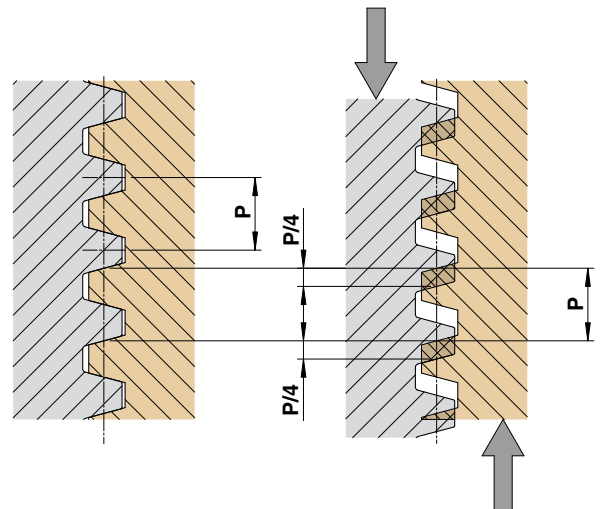

Following drawings show the possible solutions:

- check of dimension **c₁**, **c₂**, **c₃** or **c₄** for screw jacks with travelling screw (Mod. A) or of distance **b** for screw jacks with travelling nut (Mod. B) - see drawings on previous page and below - comparing the current value with the initial one (with new screw jack),
- appliance of an electric switch (see drawings below) which is activated when the pre-established wear level is reached giving an electric signal.

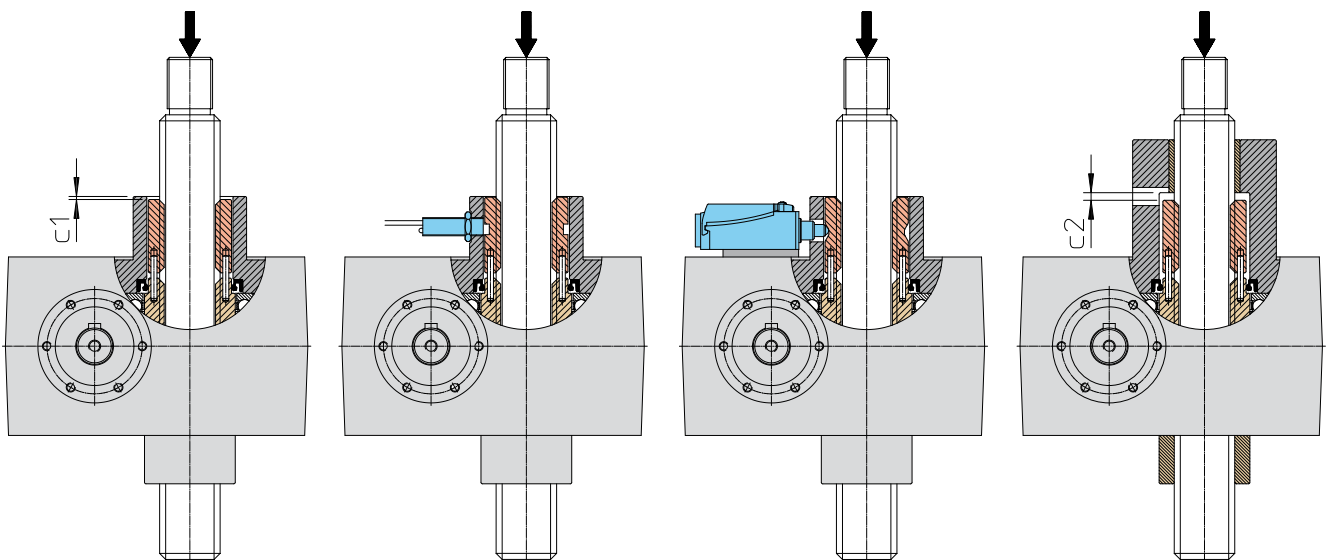

Thread wear control on screw jacks SJ Series Mod.A

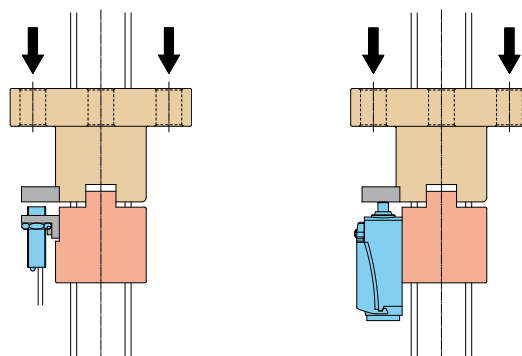

Thread wear control on screw jacks SJ Series Mod.B

Screw jacks SJ Series - options

Wormwheel rotation detector

Available for screw jacks with travelling screw (Mod. A) only. Some applications require the possibility to verify if the wormwheel rotates while the worm shaft is moving in order to get information about the good condition and functioning of the wormwheel tothing.

Usually, this device is required for applications where a safety nut is already present. A “crown” of empty and full spaces (created by machining the safety nut end, see picture on the right), while rotating, activates a corresponding proximity switch. As output of such proximity switch, activated and deactivated by the alternation of empty and full spaces, a “train” of impulses is generated and it confirms the rotation of the wormwheel. On the contrary, the constant output signal of the proximity means the stop of the wormwheel.

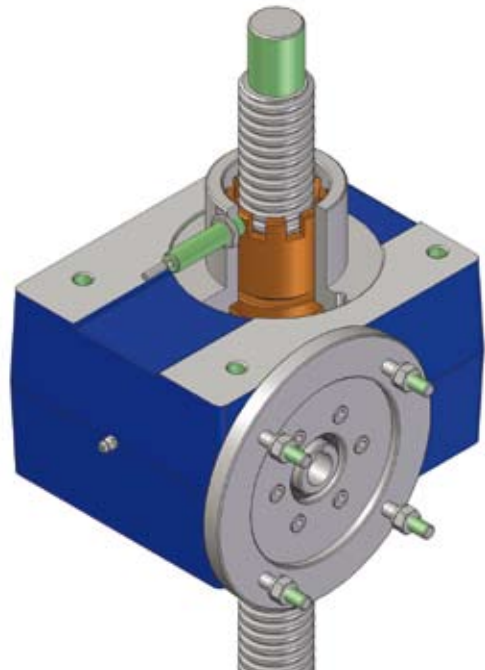

Magnetic stroke end switches

Available for screw jacks with travelling screw (Mod. A) and for size 5, 10 o 25. Not compatible with anti-turn device AR.

Functioning: the magnetic stroke end switches are sensors with reed contact and are fixed with a clamp on the protective tube T, made in aluminium or other non-magnetic metal. They are activated by the magnetic field generated by a magnetic ring fitted on the acme screw end.

In case the screw jack is not stopped after the sensor activation, without magnetic field the sensor restores the original state. In case the limit switches are used to stop the screw jack, we recommend to provide for an electric connection in order to latch the signal and to prevent that the screw jack moves again in the same direction.

Screw jacks with magnetic limit switches are supplied with two sensors for the acme screw extreme positions. On request, extra switches for intermediate distances can be supplied.

The position of the sensors along the tube is adjustable.

Technical details:

Contact:	normally CLOSED (NC)	normally OPEN (NO)
Voltage range:	(3 ... 130) Vdc / (3 ... 130) Vac	
Switching capacity:	20 W / 20 VA	
Max. switching current at 25°C:	300 mA (resistive load)	
Max. inductive load:	3 W (simple coil)	—
Wires	2 × 0.25 mm ²	
Cable length	2 m	

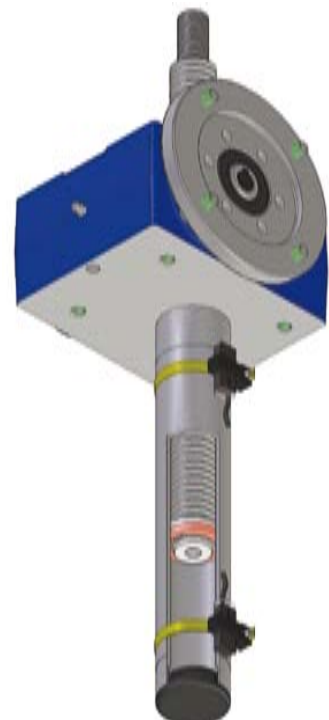

Ordering code: **FCM-NC** for screw jacks with normally closed magnetic switches FCM
 Ordering code: **FCM-NO** for screw jacks with normally open magnetic switches FCM

Screw jacks SJ Series - options

Inductive proximity stroke end switches

Available for screw jacks with travelling screw (Mod.A) only.

Functioning: proximity limit switches are PNP inductive sensors with normally CLOSED contact (NC) fitted on the protective tube and activated by the metallic ring fixed on the acme screw end.

In case the screw jack is not stopped after the sensor activation, when the metallic ring moves away the sensor restores the original state (becomes deactivated). In case the limit switches are used to stop the screw jack, we recommend to provide for an electric connection in order to latch the signal and to prevent that the screw jack moves again in the same direction.

Screw jacks with proximity limit switches are supplied with two sensors for the acme screw extreme positions. Extra switches for intermediate distances available on request.

On standard execution, the sensors position along the tube is not adjustable and is not angularly fixed. On request, it can be supplied with angular position at customer's indication.

Execution with axial adjustment of the sensors position available on request.

Technical details:

Type	inductive, PNP
Contact:	normally CLOSED (NC)
Nominal voltage:	(10 ... 30) Vdc
Max. output current:	200 mA
Voltage drop (activated sensor):	< 1.8 V
Wires	2 × 0.2 mm ²
Cable length	2 m

Ordering code: **standard FCP (not adjustable)**
adjustable FCP

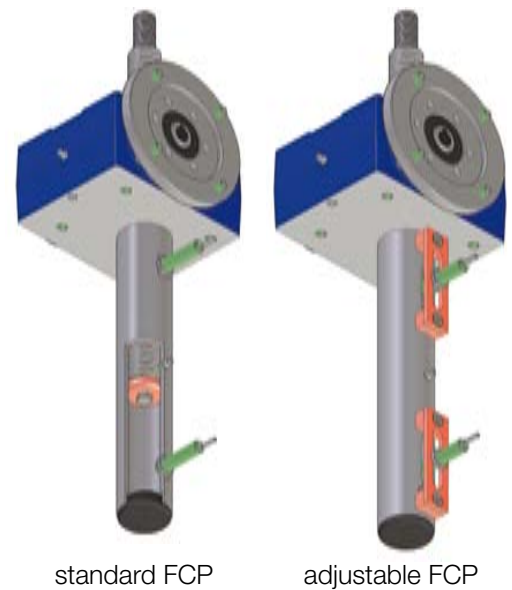

Material: stainless steel

For applications in particular environment conditions or in food industry, the screw jacks SJ Series can be supplied with stainless steel acme screw and/or screw attachment on request. Available steels: AISI 303, AISI 304, AISI 316.

Ordering code: **TR inox** stainless steel acme screw for screw jacks Mod. A or Mod. B
 Ordering code: **P inox** stainless steel flange end P, for screw jacks Mod. A
 Ordering code: **TF inox** stainless steel rod end TF, for screw jacks Mod. A

IEC motor connection

		SJ 5	SJ 10	SJ 25	SJ 50	SJ 100	SJ 150	SJ 200	SJ 250
56	B5	F							
	B14	F							
63	B5	B	F	F					
	B14		F						
71	B5		B	F	F	F			
	B14		B	F					
80	B5			B	F	F	F		
	B14			B					
90	B5			B	B	B	F		
	B14			B	B	B			
100 - 112	B5				B	B	B	F	F
	B14				B	B	B	B	B
132	B5							B	B

F - plug-in IEC flange and hollow shaft

B - bell-housing + coupling IEC

Flange or bell-housing at drawing for hydraulic motors or servomotors connection available on request.

Screw jacks SJ Series - coding description

Screw jacks SJ Series with travelling screw (Mod.A)

SJ	50	Mod.A	RL1	Vers. 3 (80 B5)	U-RH	FF	C300
1	2	3	4	5	6	7	8
TF	B	MSA	/	SC	T	AR	FCP
9							
...							
10							
...							
11							
AC 3-phase brake motor 0.75 kW 4 poles 230/400 V 50 Hz IP 55 Isol. F							
12							

1 SJ (screw jack SJ Series)

2 Screw jack size

5 ... 1000

page 56 - 57, 62 - 63

3 Mod.A (Model: travelling screw)

4 Ratio and number of acme screw starts

page 56 - 57, 62 - 63

5 Input versions

Vers.1, Vers.2, Vers.3, Vers.4, Vers.5, Vers.6

page 7

6 Screw jack mounting and input shaft position

U-RH, U-LH, D-RH, D-LH, H-RH, H-LH

page 7

7 Screw jack housing fixing holes

FF, FP

page 72

8 Screw jack stroke length (ex.: C300 = 300 mm stroke)

9 Options

NF, P, TF, N	Screw end	page 68 - 71
B	Bellows	page 74
SC	Trunnion mount	page 73
SN	Stop nut	page 72
T	Protective tube	page 72
AR	Anti-turn device	page 73
FCM-NC	Magnetic stroke end switches (normally closed)	page 78
FCP-NC	Proximity stroke end switches (PNP, normally closed)	page 79

10 Other options

example: encoder (with all relevant data)

11 Further specifications

example: stainless steel acme screw AISI 303

example: low temperature lubricant

12 Motor specifications

13 Coding form

page 81

14 Application sketch

3

Screw jacks SJ Series - coding description

Screw jacks SJ Series with travelling screw (Mod.A)

UPWARD mounting

P TF
 NF
 B SC
 Version _____
 FF FP
 SC SN T AR FCM FCP

PUSH LOAD PULL LOAD
 MSA

UPWARD mounting

DOWNWARD mounting

FCP FCM AR T SN SC
 Version _____
 FP FF SC B
 NF
 TF P

MSA
 PULL LOAD PUSH LOAD

DOWNWARD mounting

3

Screw jacks SJ Series - coding description

Screw jacks SJ Series with travelling nut (Mod.B)

SJ	50	Mod.B	RL1	Vers. 3 (80 B5)	U-RH	FF	C300
1	2	3	4	5	6	7	8
N	B2	MB+SBC	B1				
9							
...							
10							
...							
11							
AC 3-phase brake motor 0.75 kW 4 poles 230/400 V 50 Hz IP 55 Isol. F							
12							

1	SJ (screw jack SJ Series)	
2	Screw jack size	
5 ... 1000		page 56 - 57, 62 - 63
3	Mod.B (Model: travelling nut)	
4	Ratio and number of acme screw starts	page 56 - 57, 62 - 63
5	Input versions	
Vers.1, Vers.2, Vers.3, Vers.4, Vers.5, Vers.6		page 7
6	Screw jack mounting and input shaft position	
U-RH, U-LH, D-RH, D-LH, H-RH, H-LH		page 7
7	Screw jack housing fixing holes	
FF, FP		page 72
8	Screw jack stroke length (ex.: C300 = 300 mm stroke)	
9	Options	
N	Screw end	page 68 - 71
B ₁ , B ₂	Bellows	page 75
MB	Working nut	page 68 - 71
SBC	Safety nut	page 76
RMG	Adjustable backlash	page 46
10	Other options	
example: encoder (with all relevant data)		
11	Further specifications	
example: stainless steel acme screw AISI 303		
example: low temperature lubricant		
12	Motor specifications	
13	Coding form	page 83
14	Application sketch	

3

Screw jacks SJ Series - coding description

Screw jacks SJ Series with travelling nut (Mod.B)

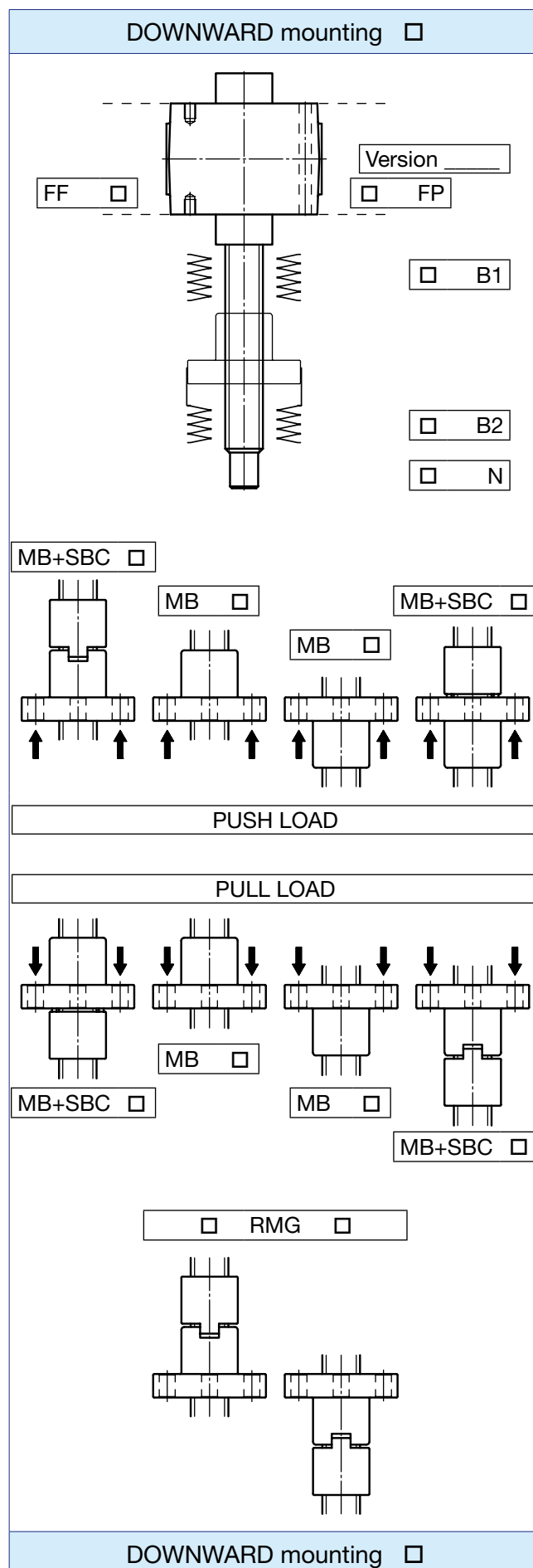
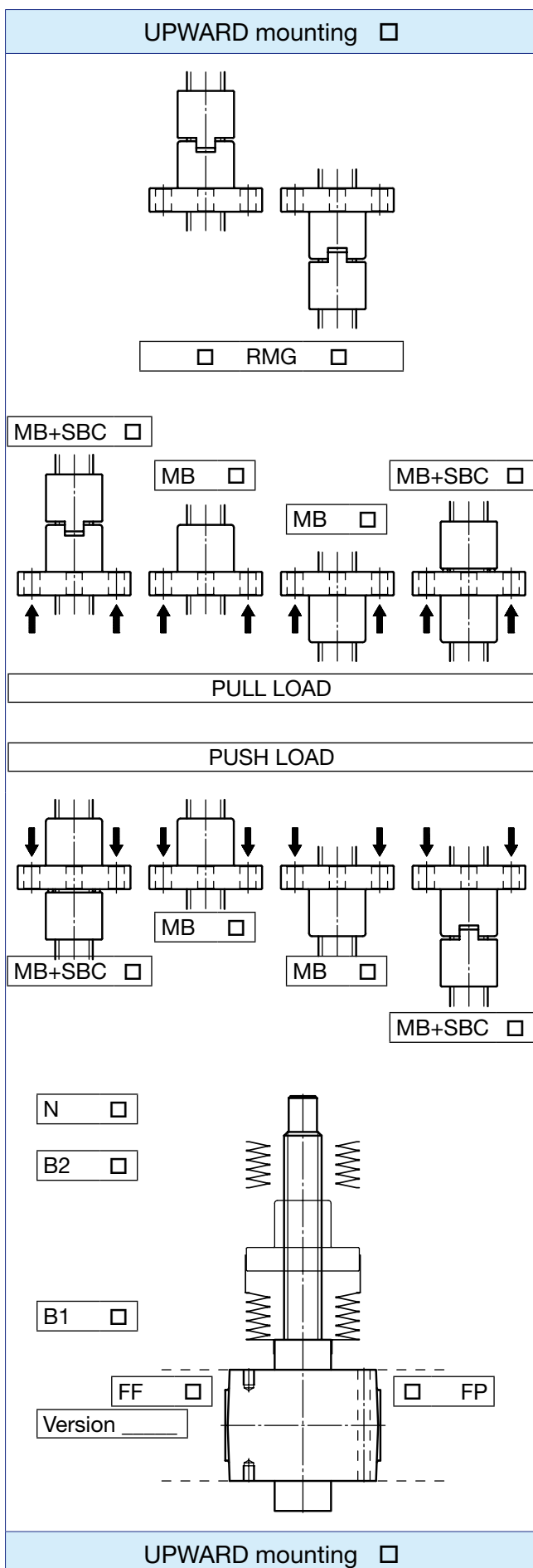

3

Screw jacks SJ Series

Screw jacks SJ Series with travelling screw (Mod. A) - spare parts

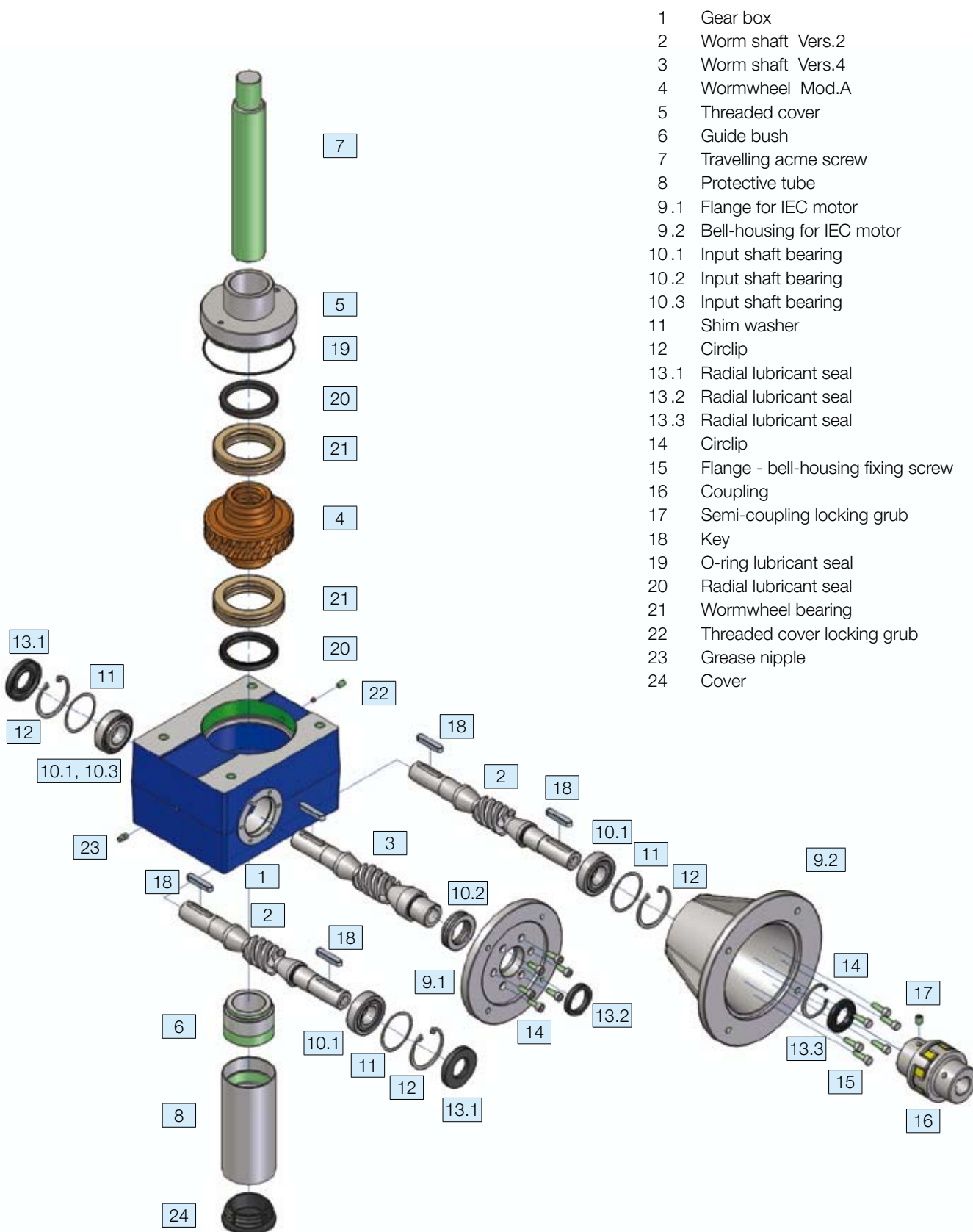

- 1 Gear box
- 2 Worm shaft Vers.2
- 3 Worm shaft Vers.4
- 4 Wormwheel Mod.A
- 5 Threaded cover
- 6 Guide bush
- 7 Travelling acme screw
- 8 Protective tube
- 9.1 Flange for IEC motor
- 9.2 Bell-housing for IEC motor
- 10.1 Input shaft bearing
- 10.2 Input shaft bearing
- 10.3 Input shaft bearing
- 11 Shim washer
- 12 Circlip
- 13.1 Radial lubricant seal
- 13.2 Radial lubricant seal
- 13.3 Radial lubricant seal
- 14 Circlip
- 15 Flange - bell-housing fixing screw
- 16 Coupling
- 17 Semi-coupling locking grub
- 18 Key
- 19 O-ring lubricant seal
- 20 Radial lubricant seal
- 21 Wormwheel bearing
- 22 Threaded cover locking grub
- 23 Grease nipple
- 24 Cover

For spare parts orders we recommend you to refer to the relative product serial number, marked on the product label fixed on the screw jack housing.

Screw jacks SJ Series

Screw jacks SJ Series with travelling nut (Mod. B) - spare parts

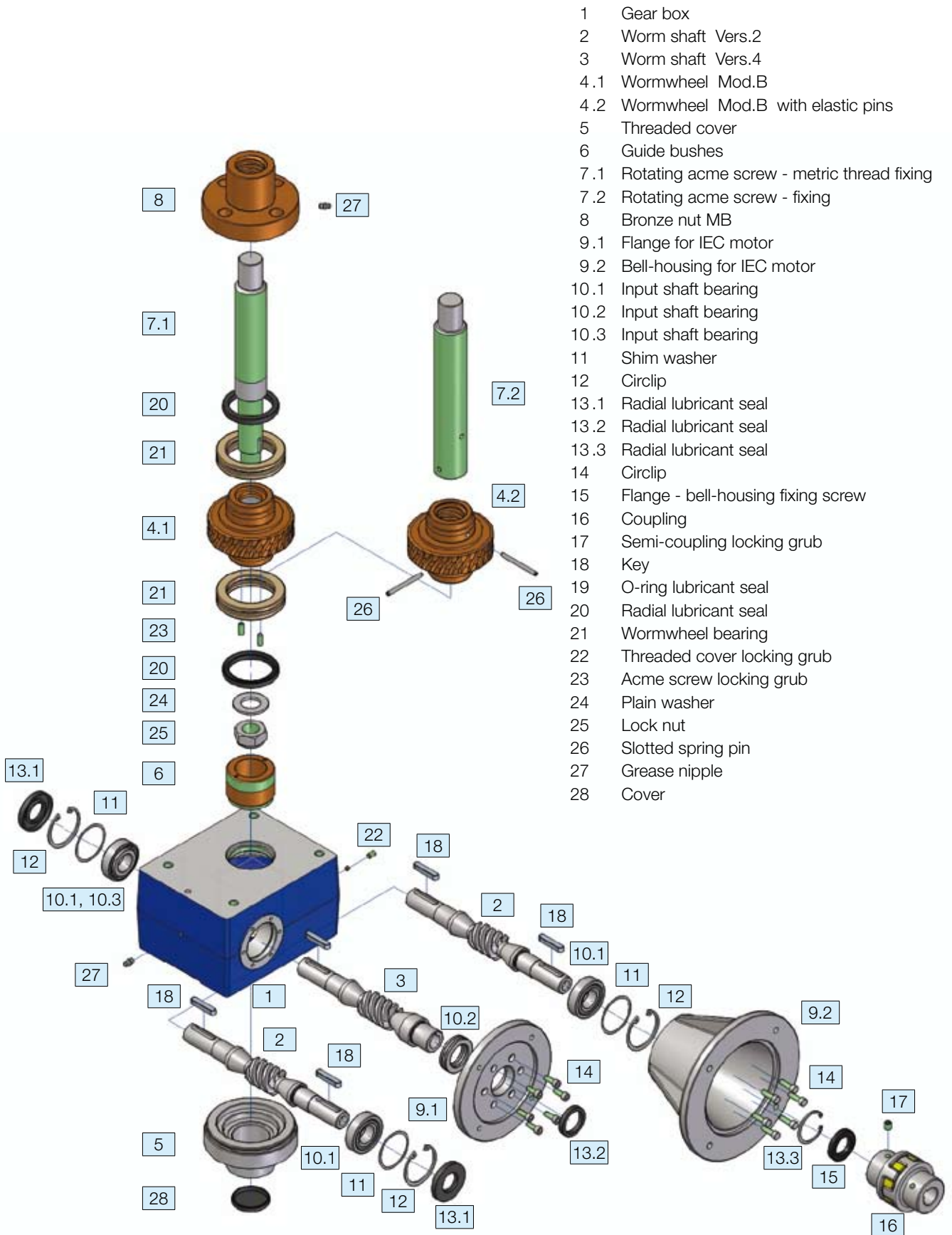

- 1 Gear box
- 2 Worm shaft Vers.2
- 3 Worm shaft Vers.4
- 4.1 Wormwheel Mod.B
- 4.2 Wormwheel Mod.B with elastic pins
- 5 Threaded cover
- 6 Guide bushes
- 7.1 Rotating acme screw - metric thread fixing
- 7.2 Rotating acme screw - fixing
- 8 Bronze nut MB
- 9.1 Flange for IEC motor
- 9.2 Bell-housing for IEC motor
- 10.1 Input shaft bearing
- 10.2 Input shaft bearing
- 10.3 Input shaft bearing
- 11 Shim washer
- 12 Circlip
- 13.1 Radial lubricant seal
- 13.2 Radial lubricant seal
- 13.3 Radial lubricant seal
- 14 Circlip
- 15 Flange - bell-housing fixing screw
- 16 Coupling
- 17 Semi-coupling locking grub
- 18 Key
- 19 O-ring lubricant seal
- 20 Radial lubricant seal
- 21 Wormwheel bearing
- 22 Threaded cover locking grub
- 23 Acme screw locking grub
- 24 Plain washer
- 25 Lock nut
- 26 Slotted spring pin
- 27 Grease nipple
- 28 Cover

3

For spare parts orders we recommend you to refer to the relative product serial number, marked on the product label fixed on the screw jack housing.

INSTALLATION – MAINTENANCE – LUBRICANTS

Transport and handling

Screw jacks with mounted acme screw and all relevant fittings can be often difficult to handle because of their overall dimensions. Therefore, we recommend to handle the products with care during transport and handling to avoid damages of the mechanical parts and/or fittings and also to prevent any risk for the employed personnel. Screw jack supporting points should be previously identified and used during transport or to raise it by handling. In case of doubts, please contact SERVOMECH S.p.A. for support to prevent any possible damage!

Storage

During storage, screw jacks shall be protected against atmospheric agents and the risk that dust or other pollutants settle on the acme screw and on other moving parts.

In case of long storage periods, for example more than 6 months, it is necessary to move the input shafts to avoid damaging of the bearings. Furthermore, keep all not painted parts properly lubricated to prevent oxidation.

Installation

The screw jack must be installed to work with push or pull axial load only, avoiding lateral and radial load. The correct perpendicularity between acme screw axis and screw jack fixing plane shall be checked carefully.

The installation of many screw jacks for synchronized lifting movement requires particular attention on two different factors:

- alignment of load supporting points: screw ends in case of travelling acme screw, bronze nut in case of travelling nut;
- use of shafts and couplings with high torsional stiffness, to assure a perfect synchronism of all lifting points.

Commissioning and use

SERVOMECH screw jacks are supplied with lubricant type and quantity as indicated in the lubricants table.

ATTENTION! If not otherwise agreed, the acme screw is usually not lubricated! The first acme screw lubrication must be done by the customer during the installation and strictly before using the screw jack.

Before activating the screw jack, the following checks must be carried out:

- input shaft rotating direction and relative acme screw or nut linear motion direction;
- stroke end switches position cannot exceed the given limits;
- proper connection of mechanical drive and electric motor (rotating direction and motor supply voltage).

During commissioning, do never exceed the duty cycle F_u [%] allowed for the screw jack! Any abuse of such duty cycle F_u [%] can cause overheating and unintentional premature damaging.

Maintenance

Scheduled maintenance shall be carried out on screw jacks depending on the relevant use and environment conditions.

Acme screws must be periodically greased with the lubricant stated in the table or equivalent one.

Further worm gearbox lubrication has to be done only in case of verified lubricant leakage.

For further information about installation and maintenance refer to the screw jacks Use and Maintenance Manual.

Lubricants table

SCREW JACK	WORM GEARBOX	ACME SCREW - NUT		
MA 5	AGIP Grease SLL 00	SHELL DARINA Grease 2		
MA 10			0.07 kg	
MA 25	AGIP BLASIA S 220 (oil)		0.14 kg	
MA 50			0.35 liter	
MA 80			0.75 liter	
MA 100			0.75 liter	
MA 200			1.5 liter	
MA 350			2.3 liter	
SJ 5			AGIP Grease SM2	4 liter
SJ 10				0.07 kg
SJ 25	0.14 kg			
SJ 50	0.23 kg			
SJ 100	0.6 kg			
SJ 150	0.5 kg			
SJ 200	1.5 kg			
SJ 250	2 kg			
SJ 300	2 kg			
SJ 350	2 kg			
SJ 400	AGIP Grease SLL 00	3 kg		
SJ 600		3 kg		
SJ 800		8 kg		
SJ 1000		8 kg		

PRODUCT LABEL

Every SERVOMECH screw jack is provided with a product label, see picture below, which allows the unit identification and gives technical information about the product.

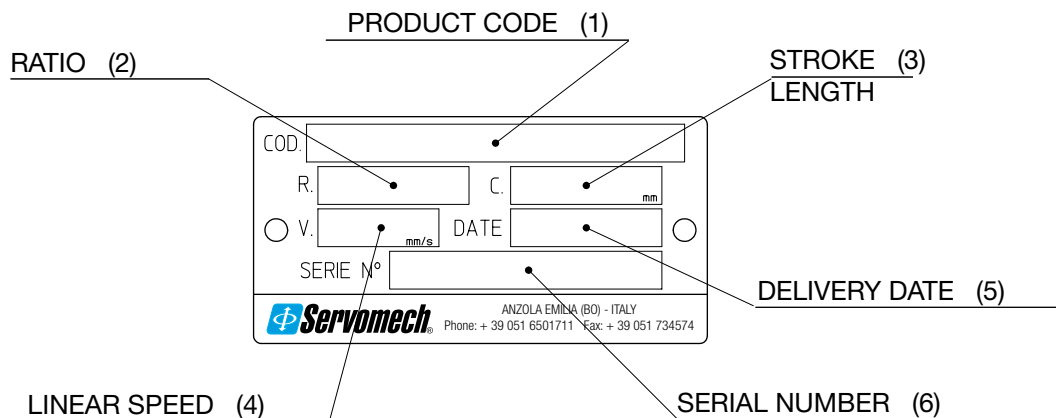

- 1) **Product code:** is an alphanumeric code stating the type, size ratio, input version and stroke end switches of the unit;
- 2) **Ratio:** is the ratio of worm gear;
- 3) **Stroke length:** is the stroke length in millimetres (mm) achievable by the screw jack;
- 4) **Linear speed:** is the screw jack linear speed in millimetres per second (mm/s), for screw jacks supplied with an electric motor; if the motor is not supplied, the field is blank;
- 5) **Delivery date:** is the assembly date, expressed in week/year (example: 37/10 = week 37 of year 2010), which usually is also the delivery date; this date is considered as warranty reference;
- 6) **Serial number:** is the number referred to the unit and assures the exact identification of the product, even after a long time; it must be given as reference when ordering spare parts for the unit.

Company: _____
 Address: _____
 Contact person: _____ Position: _____
 Telephone: _____ Fax: _____ E-mail: _____

APPLICATION: _____

SKETCH - APPLICATION LAYOUT – plane view

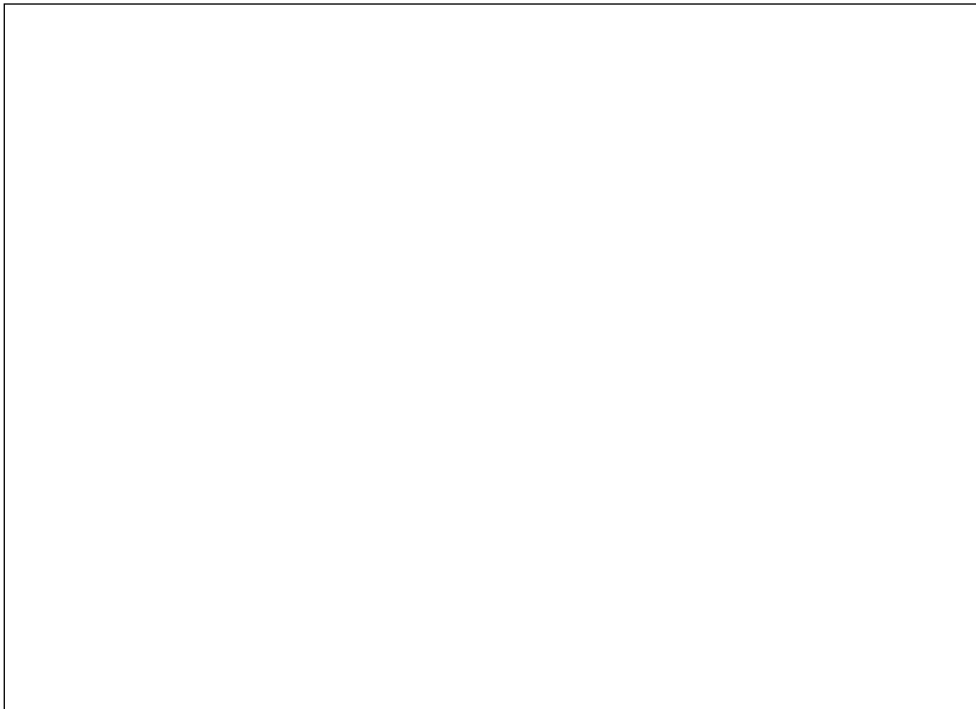

Example

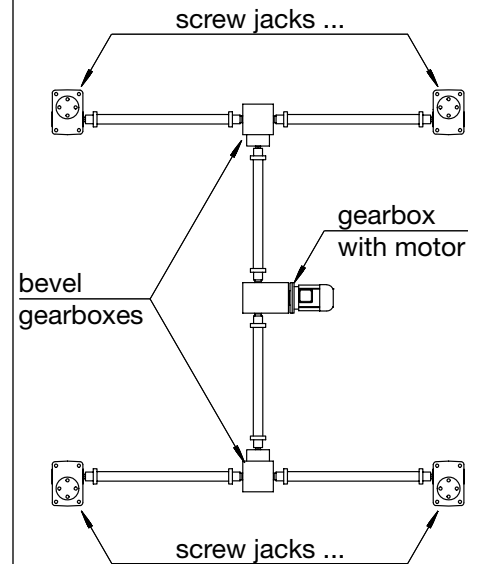

Side view of a single screw jack

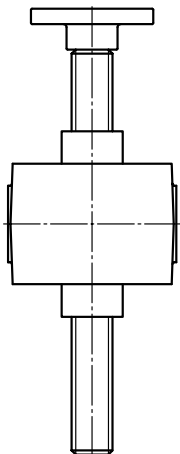

UPWARD MOUNTING

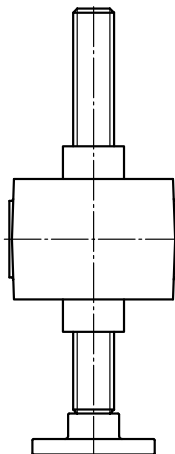

DOWNWARD MOUNTING

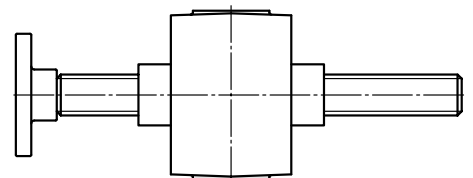

HORIZONTAL MOUNTING

NUMBER OF SCREW JACKS PER APPLICATION: _____

STROKE REQUIRED: _____ mm ACME SCREW LENGTH: _____ mm

TOTAL STATIC LOAD FOR APPLICATION: PULL: _____ daN PUSH: _____ daN

MAX. STATIC LOAD FOR **SINGLE SCREW JACK**: PULL: _____ daN PUSH: _____ daN at STROKE _____ mm

SCREW JACK MOUNTING:

- Euler I (screw jack housing firmly fixed to the base – free acme screw end)
- Euler II (screw jack housing and acme screw end fixed to pivoting supports)
- Euler III (screw jack housing firmly fixed to the base – guided acme screw end)

SCREW JACK SUBJECTED TO VIBRATIONS NOT SUBJECTED TO VIBRATIONS

TOTAL DYNAMIC LOAD FOR APPLICATION: PULL: _____ daN PUSH: _____ daN

MAX. DYNAMIC LOAD FOR **SINGLE SCREW JACK**: PULL: _____ daN PUSH: _____ daN at STROKE _____ mm

LINEAR SPEED REQUIRED: _____ mm/s _____ mm/min _____ m/min SINGLE STROKE PERFORMING TIME: ____ s

DUTY CYCLE: _____ cycles / hour _____ working hours / day Notes: _____

LIFETIME REQUIRED: _____ cycles _____ clock hours _____ calendar days Notes: _____

ENVIRONMENT: TEMPERATURE _____ °C DUST HUMIDITY ____ % POLLUTER _____

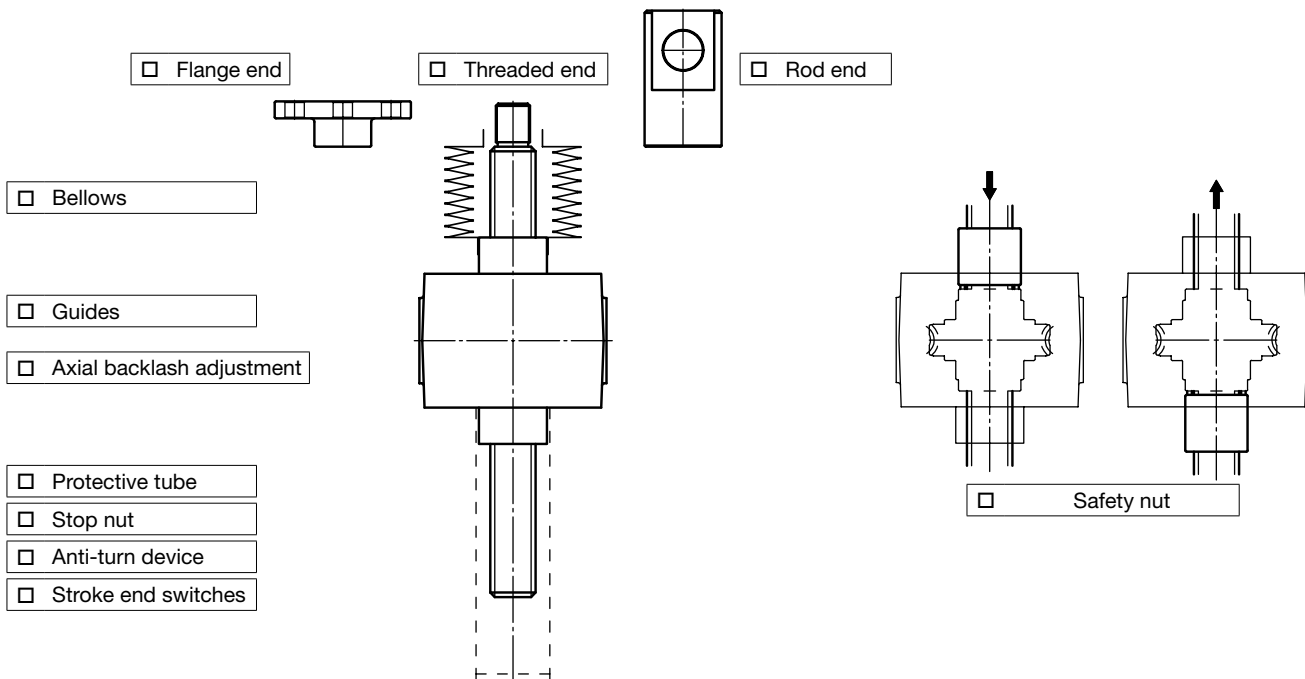

Suggestions based on previous experiences of similar application: _____

Notes: _____

Number of screw jacks required: _____

Company: _____

Address: _____

Contact person: _____ Position: _____

Telephone: _____ Fax: _____ E-mail: _____

APPLICATION: _____

SKETCH - APPLICATION LAYOUT – plane view

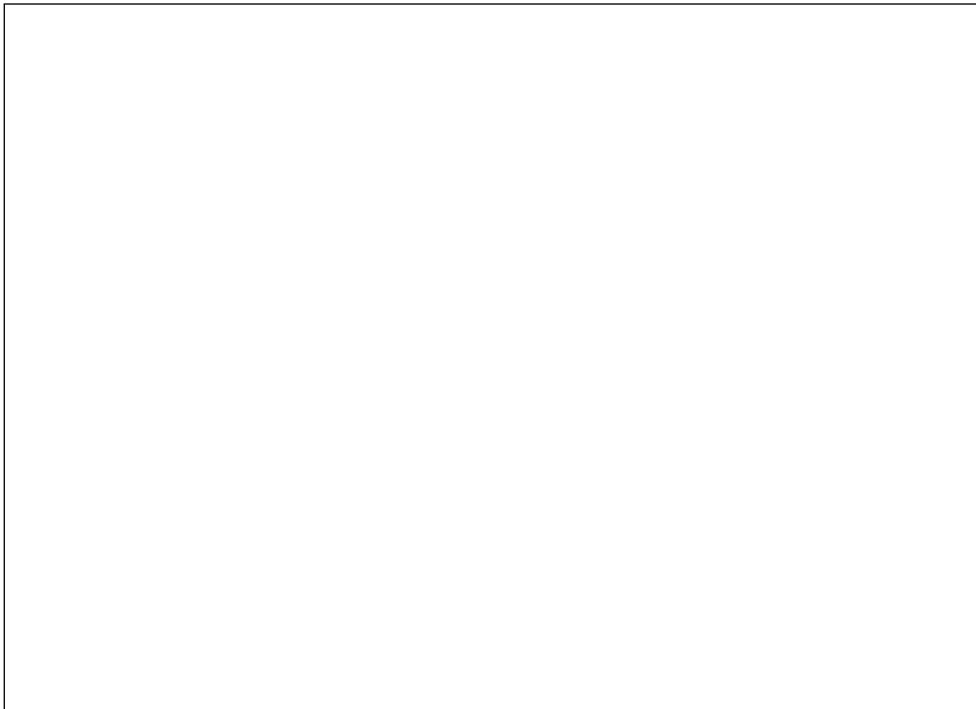

Example

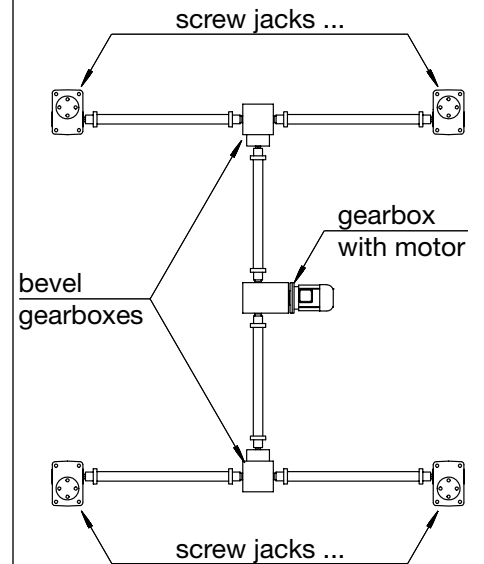

Side view of a single screw jack

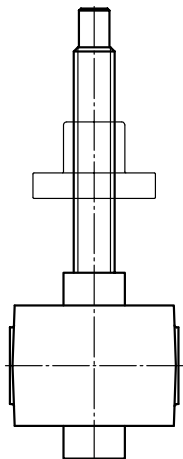

UPWARD MOUNTING

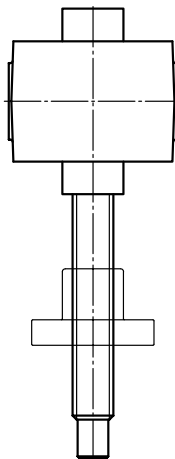

DOWNWARD MOUNTING

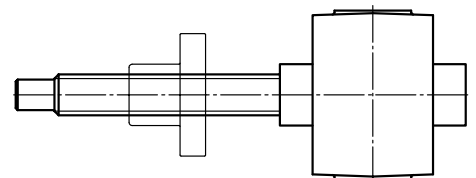

HORIZONTAL MOUNTING

NUMBER OF SCREW JACKS PER APPLICATION: _____

STROKE REQUIRED: _____ mm ACME SCREW LENGTH: _____ mm

TOTAL STATIC LOAD FOR APPLICATION: PULL: _____ daN PUSH: _____ daN

MAX. STATIC LOAD FOR **SINGLE SCREW JACK**: PULL: _____ daN PUSH: _____ daN at STROKE _____ mm

SCREW JACK MOUNTING:

- Euler I (screw jack housing firmly fixed to the base – free acme screw end)
- Euler II (screw jack housing and acme screw end fixed to pivoting supports)
- Euler III (screw jack housing firmly fixed to the base – guided acme screw end)

SCREW JACK SUBJECTED TO VIBRATIONS NOT SUBJECTED TO VIBRATIONS

TOTAL DYNAMIC LOAD FOR APPLICATION: PULL: _____ daN PUSH: _____ daN

MAX. DYNAMIC LOAD FOR **SINGLE SCREW JACK**: PULL: _____ daN PUSH: _____ daN at STROKE _____ mm

LINEAR SPEED REQUIRED: _____ mm/s _____ mm/min _____ m/min SINGLE STROKE PERFORMING TIME: ____ s

DUTY CYCLE: _____ cycles / hour _____ working hours / day Notes: _____

LIFETIME REQUIRED: _____ cycles _____ clock hours _____ calendar days Notes: _____

ENVIRONMENT: TEMPERATURE _____ °C DUST HUMIDITY ____ % POLLUTER _____

Cylindrical end

Bellows

Bronze nut

Bellows

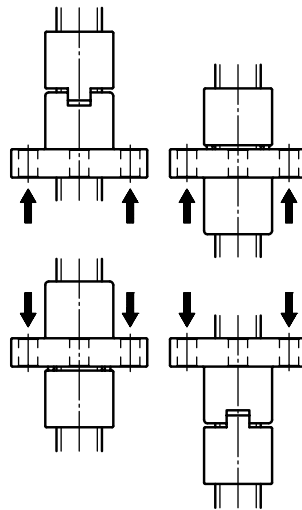
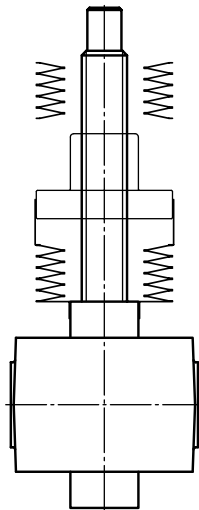

Safety nut

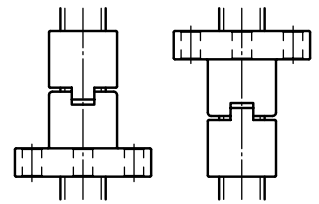

Axial backlash adjustment

Suggestions based on previous experiences of similar application: _____

Notes: _____

Number of screw jacks required: _____

CODE: _____

STROKE: _____

ACME SCREW: _____ BALL SCREW: _____

ACCESSORIES: _____

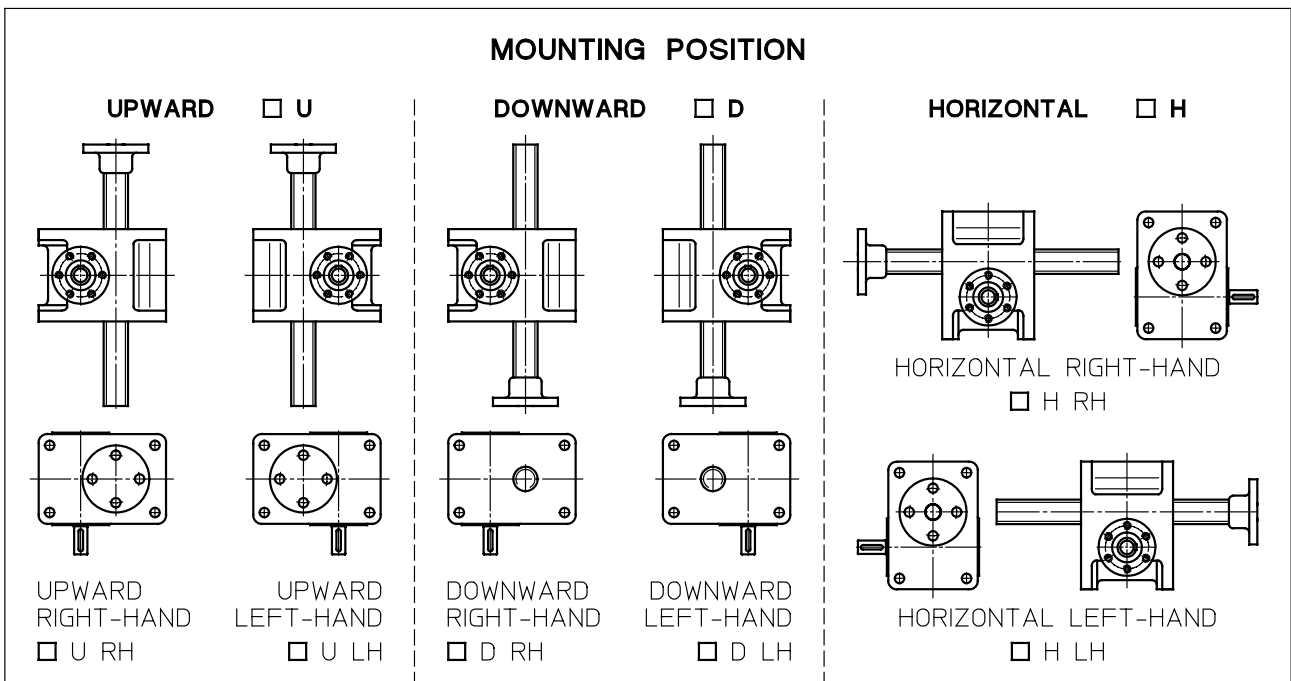
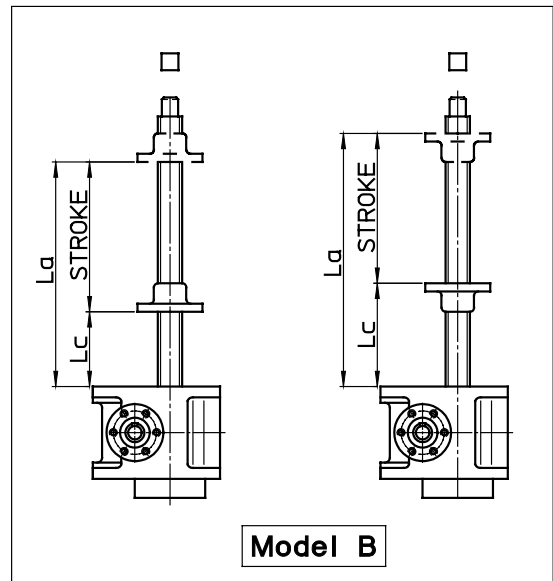
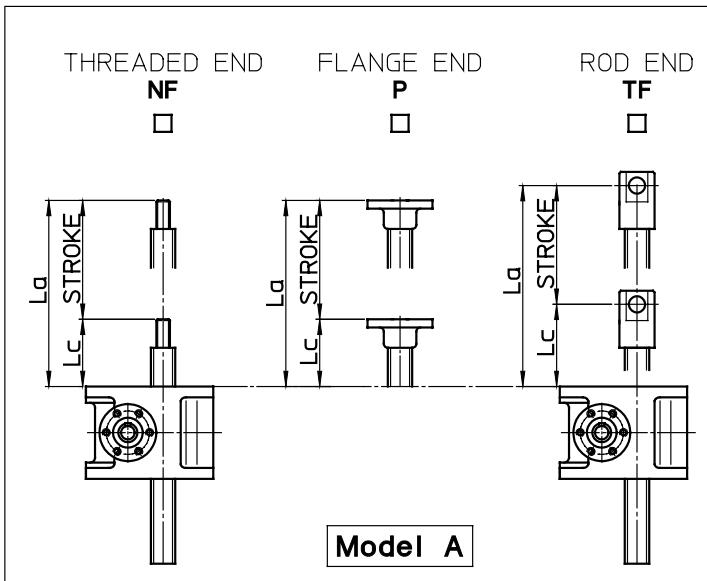

SCREW JACKS MAIN DIMENSIONS:

RETRACTED JACK LENGTH: **Lc** = _____ mm

EXTENDED JACK LENGTH: **La** = _____ mm

MAX. WORKING STROKE ($La - Lc$): **C** = _____ mm

Servomech QMS
PASSED
Date: _____
Signature: _____

4

INPUT SHAFT ROTATION – SCREW OR NUT LIFTING DIRECTION

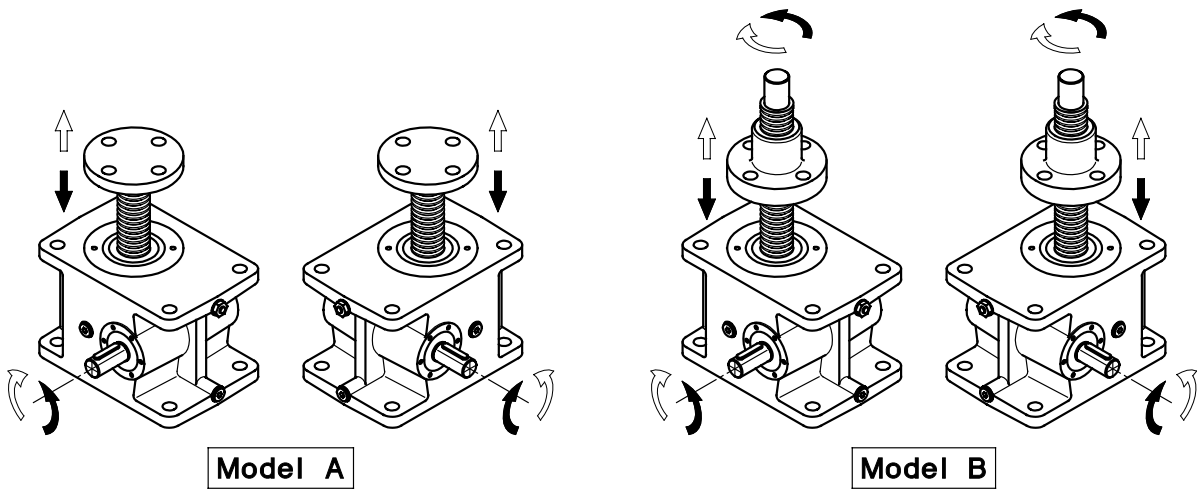

WARNING!

1. The values **Lc** (retracted jack length), **La** (extended jack length) and **C** (max. working stroke) are the extreme permissible values.
2. For a correct installation and commissioning of the screw jack see The Installation, Use and Maintenance Manual.
3. The following operations must be done **BEFORE** commissioning:
 - ensure that the breather plug is in the highest position respect to all other plugs;
 - lubricate acme or ball screw – nut;
 - connect the stroke limit device to the electric control circuit of the screw jack or lifting system;
 - check the lifting direction of the acme or ball screw (Model A) or nut (Model B).

NOTE: _____

WORMGEAR LUBRICANT: _____

SCREW – NUT LUBRICANT: _____

SERVOMECH s.p.a.
 Via Monaldo Calari, 1 40011 Anzola Emilia (BO) ITALY
 Phone: + 39 051 6501.711 Fax: + 39 051 734574 E-mail: info@servomech.com

Screw jacks

SCREW JACK LIFTING SYSTEMS

SERVOMECH can support customers by selecting the complete drive solution for screw jack systems:

- screw jacks with flange for motor mounting or with input shaft,
- AC 3-phase or 1-phase electric motors, DC electric motors, servomotors
- inverter drives
- screw jacks with control of axial position and linear speed
- bevel gears
- connecting transmission shafts and couplings
- general technical support, for example:
 - screw jack selection
 - lifetime estimation and calculation
 - lay-out system drawings
 - 3D models and 2D drawings available through web-configurator on www.servomech.com or via e-mail, on specific request to SERVOMECH Engineering Dpt.

Single motorized screw jack

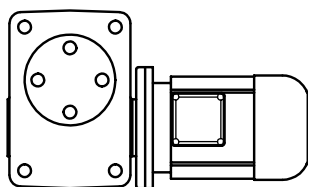

Screw jack
with plug-in flange and hollow input shaft+
IEC B5 or B14 motor

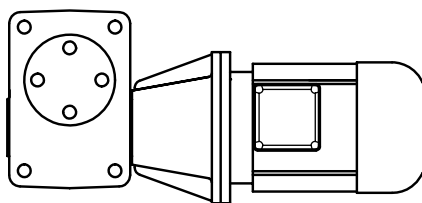

Screw jack
with bell-housing and coupling +
IEC B5 or B14 motor

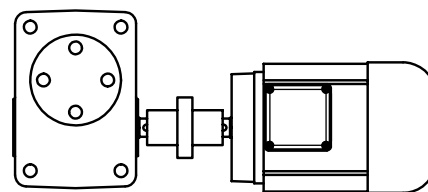

Screw jack with single input shaft +
coupling +
IEC B3 motor

LAY-OUT: Two points lifting systems

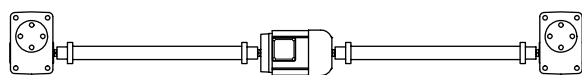

Lay-out: 2-1

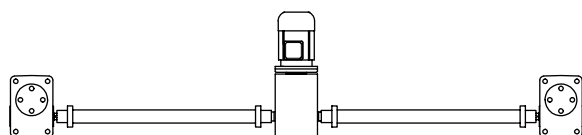

Lay-out: 2-2



Lay-out: 2-3

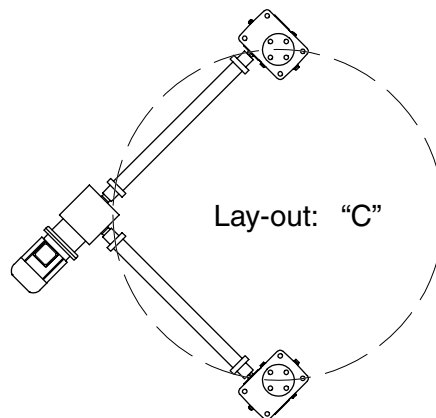

Lay-out: "C"

SCREW JACK LIFTING SYSTEMS

LAY-OUT: Three points lifting systems

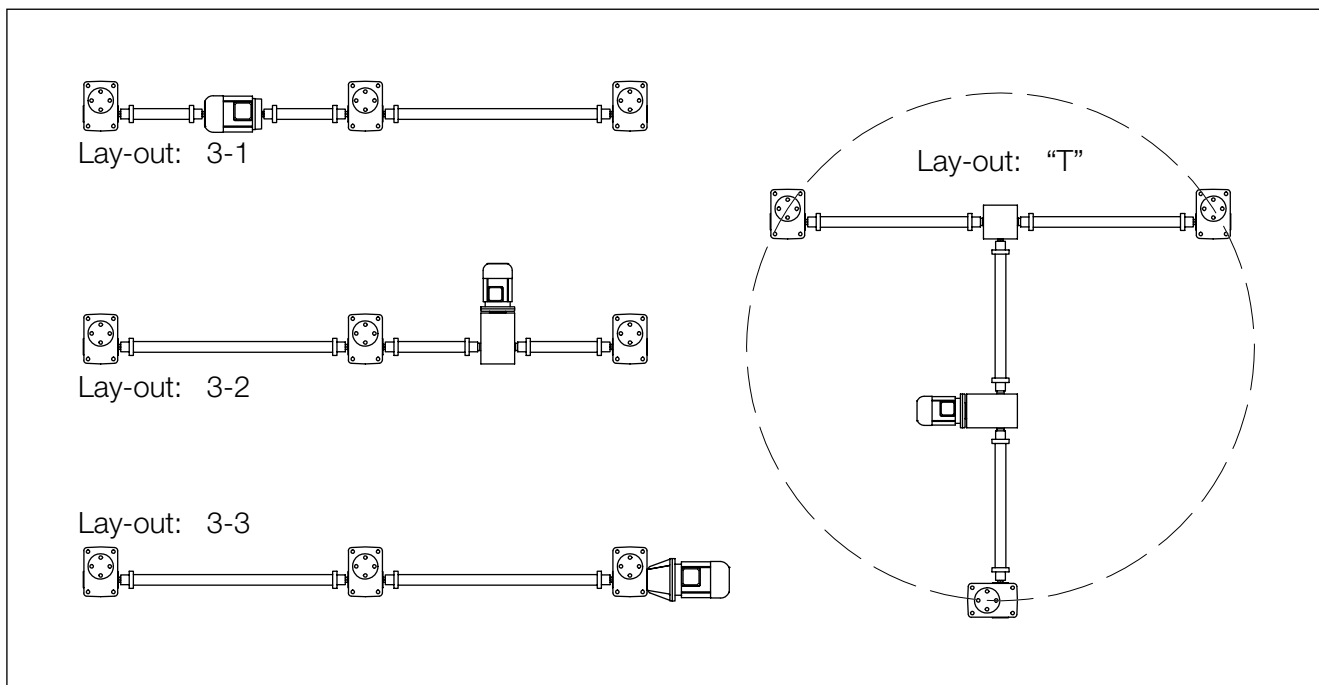

LAY-OUT: Four points lifting systems

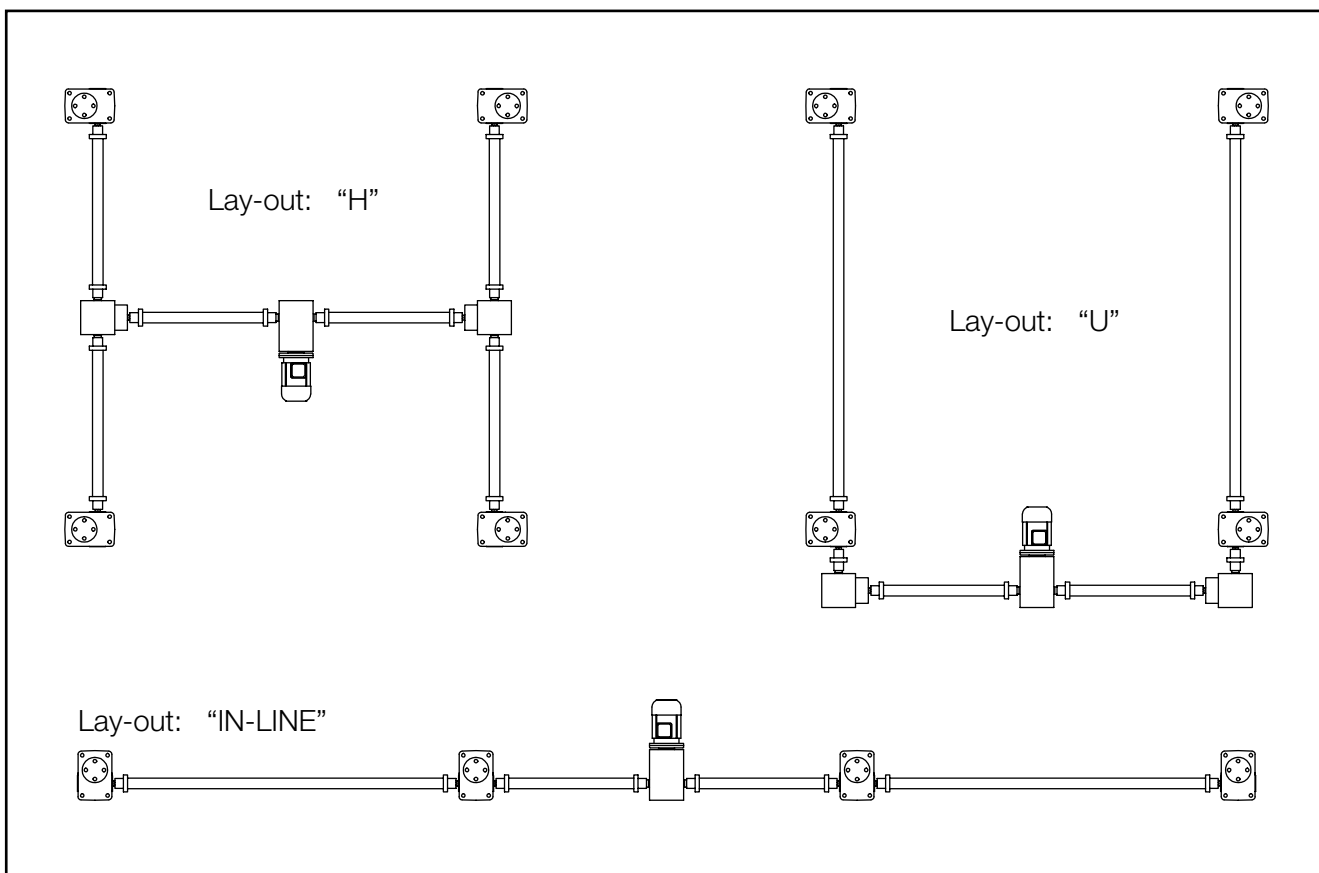

Linear actuators

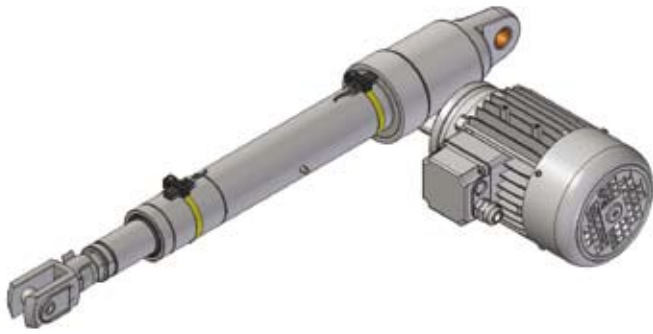

ATL Series with acme screw

- 7 sizes available
- load capacity from 4 kN to 80 kN
- linear speed from 1.5 mm/s to 150 mm/s

BSA Series with ball screw

- 7 sizes available
- load capacity from 4 kN to 60 kN
- linear speed from 1.5 mm/s to 120 mm/s

UAL Series with acme screw

- 5 sizes available
- load capacity from 2 kN to 15 kN
- linear speed from 20 mm/s to 500 mm/s

UBA Series with ball screw

- 5 sizes available
- load capacity from 2 kN to 15 kN
- linear speed from 40 mm/s to 500 mm/s

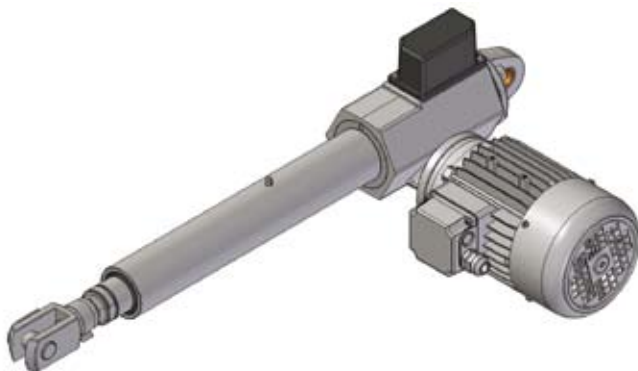
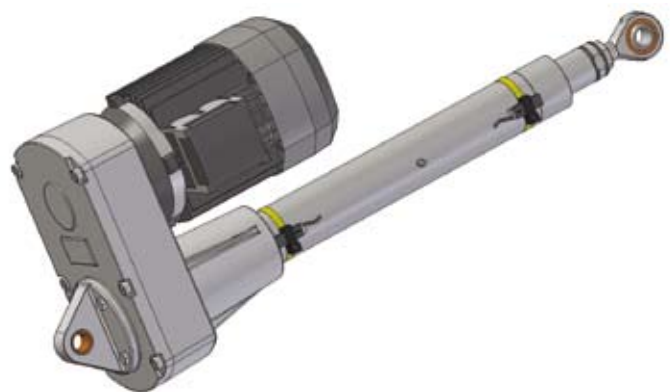

CLA Series with acme screw

- 3 sizes available
- load capacity from 8 kN to 25 kN
- linear speed from 4 mm/s to 56 mm/s

CLB Series with ball screw

- 3 sizes available
- load capacity from 6 kN to 25 kN
- linear speed from 5 mm/s to 80 mm/s

SEA Series with acme screw

- 5 sizes available
- load capacity from 15 kN to 200 kN
- linear speed from 2 mm/s to 70 mm/s

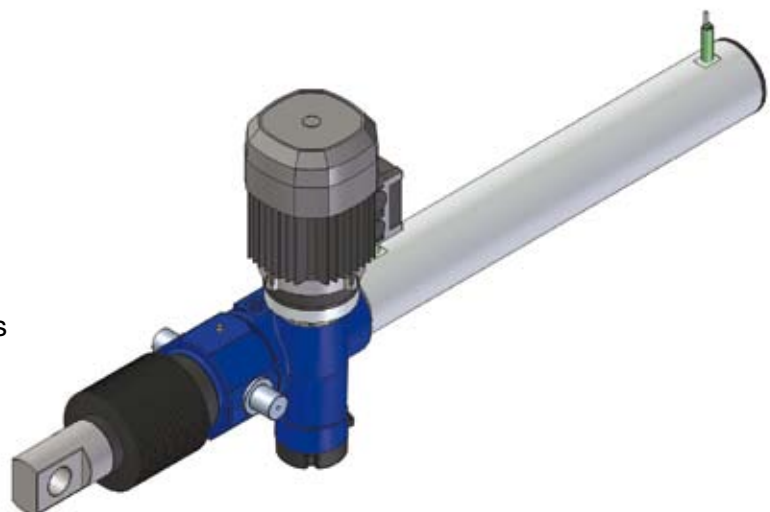

Ball screw jacks

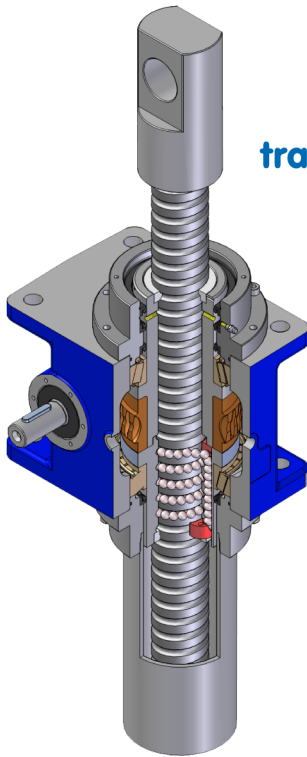

travelling screw

- High performances, accuracy and stiffness. Duty cycle up to 100 % (continuous).
- Design totally patented
- Patented lubrication system ball nut with large grease reserve
- Load capacity from 10 kN to 200 kN

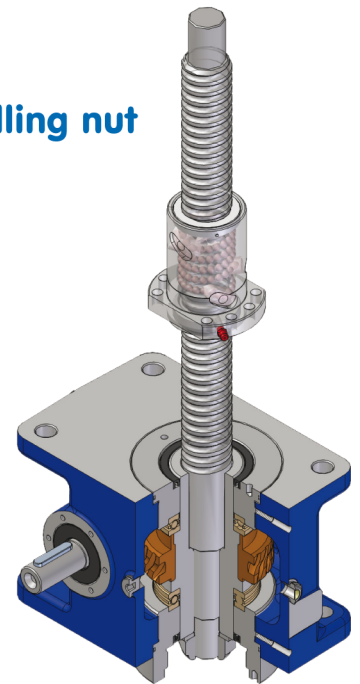

travelling nut

Ball screws and nuts

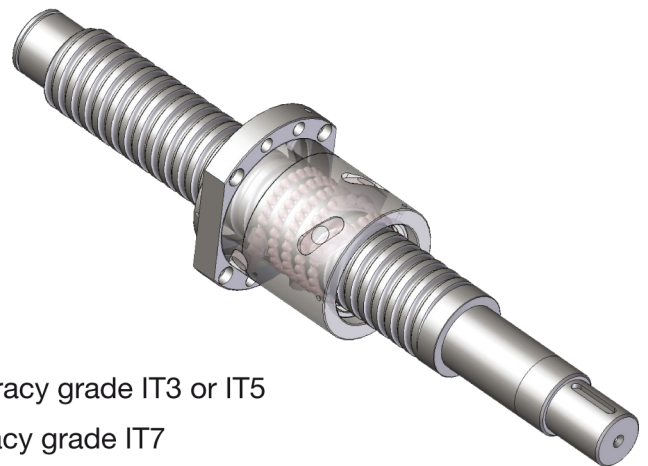
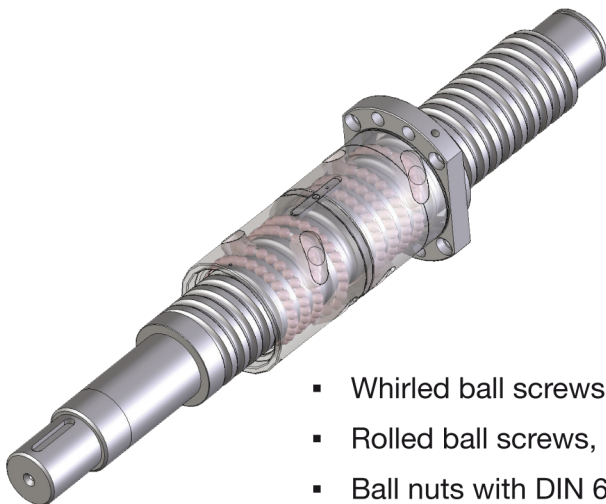

- Whirled ball screws, accuracy grade IT3 or IT5
- Rolled ball screws, accuracy grade IT7
- Ball nuts with DIN 69051 flange or cylindrical flange
- Backlash-free or preloaded ball nuts

Italian technology

own production

entire in-house manufacturing

Ask for technical catalogues at:
info@servomech.com

Linear Actuators

Servomech Product Range
includes also:

Acme and Ball Screw Linear Actuators

To receive a free copy of
our "Linear Actuators Catalogue"

Tel: +39-051-6501711

Fax: +39-051-734574

www.servomech.com

info@servomech.com



Distributed by:

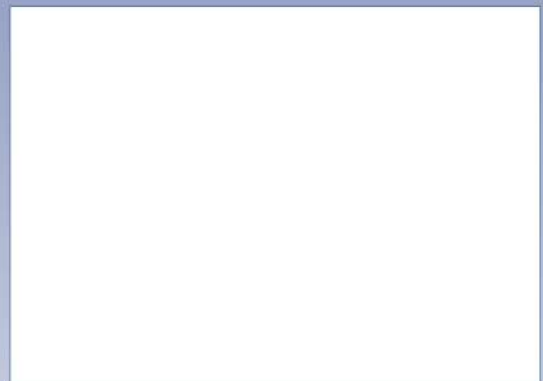

 **Servomech**[®]
new ideas in linear motion

SERVOMECH s.p.a.

Via M. Calari, 1 - 40011 Anzola dell'Emilia (Bologna) - Italy

Phone: + 39 051 6501711 - Fax: + 39 051 734574

www.servomech.com e-mail: info@servomech.com

